

Litigation

June 2, 1971

Alderson Reporting Co., Inc.
300 Seventh, S. W.
Washington, D. C.

Gentlemen:

On May 7 I wrote you requesting a copy of the transcript of oral arguments before the Supreme Court in Blonder-Tongue Laboratories, Inc. v. University of Illinois Foundation et al, No. 338. We represent the petitioner in this matter, which has been remanded to the District Court for further proceedings. It is important that we have a copy of the transcript in connection with further work on this matter.

Very truly yours,

Richard S. Phillips

RSP:iag

RINES AND RINES
ATTORNEYS AT LAW
NO. TEN POST OFFICE SQUARE
BOSTON, MASSACHUSETTS 02109

DAVID RINES
ROBERT H. RINES

CABLE SENIR
TELEPHONE HUBBARD 2-3289

May 24, 1971

Richard S. Phillips, Esq.
Hofgren, Wegner, Allen, Stelman, & McCord
20 North Wacker Drive
Chicago, Illinois 60606

Re: UIF v. BT

Dear Dick:

In reply to your letter of May 5, we would like to ask you to amend the answer and we would like you to give consideration to filing a motion for judgment as suggested by the Supreme Court on page 35, before paragraph "c".

In this connection, it should be noted that the Supreme Court has already ruled that the District Court in the Wineguard did follow "the inquiry mandated by Graham v. John Deere Co." as stated in the first page of its decision, so that this is not available as an exception to Trippett v. Lowell.

We shall be abroad for June and a good part of July and so will rely on you to hold the fort in Chicago, and also to do what you can to get reimbursement of printing and other costs for Blonder Tongue.

Very truly yours,

RINES AND RINES

By 

RHR/ch

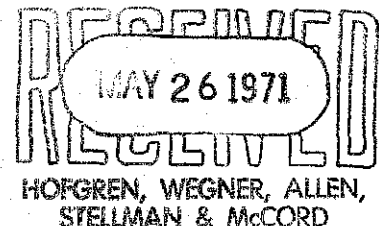

RINES AND RINES
NO. TEN POST OFFICE SQUARE, BOSTON

May 24, 1971

John F. Pearne, Esq.
McNenny, Farrington, Pearne & Gordon
920 Midland Building
Cleveland, Ohio 44115

Dear John:

In reply to your letter of May 5 with regard to the Blonder-Tongue matter, we are pleading estoppel and are planning to move for judgment as suggested by the Supreme Court in the Blonder-Tongue decision.

Very truly yours,

RINES AND RINES

By _____
Robert H. Rines

RHR/ch
cc:Richard S. Phillips, Esq. ✓

C
O
P
Y

RINES AND RINES
ATTORNEYS AT LAW
NO. TEN POST OFFICE SQUARE
BOSTON, MASSACHUSETTS 02109

DAVID RINES
ROBERT H. RINES

CABLE SENIR
TELEPHONE HUBBARD 2-3289

May 24, 1971

Richard S. Phillips, Esq.
Hofgren, Wegner, Allen, Stellman, & McCord
20 North Wacker Drive
Chicago, Illinois 60606

Re: UIF v. BT

Dear Dick:

In reply to your letter of May 5, we would like to ask you to amend the answer and we would like you to give consideration to filing a motion for judgment as suggested by the Supreme Court on page 35, before paragraph "c".

In this connection, it should be noted that the Supreme Court has already ruled that the District Court in the Wineguard did follow "the inquiry mandated by Graham v. John Deere Co." as stated in the first page of its decision, so that this is not available as an exception to Triplett v. Lowell.

We shall be abroad for June and a good part of July and so will rely on you to hold the fort in Chicago, and also to do what you can to get reimbursement of printing and other costs for Blonder Tongue.

Very truly yours,

RINES AND RINES

By 

RHR/ch

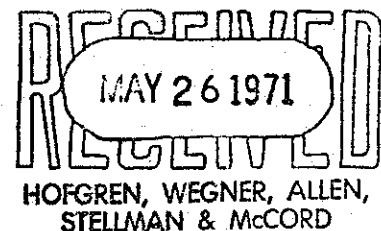

RINES AND RINES
NO. TEN POST OFFICE SQUARE. BOSTON

May 24, 1971

John F. Pearne, Esq.
McNenny, Farrington, Pearne & Gordon
920 Midland Building
Cleveland, Ohio 44115

Dear John:

In reply to your letter of May 5 with regard to the Blonder-Tongue matter, we are pleading estoppel and are planning to move for judgment as suggested by the Supreme Court in the Blonder-Tongue decision.

Very truly yours,

RINES AND RINES

By _____
Robert H. Rines

RHR/ch
cc:Richard S. Phillips, Esq.

C
O
P
Y

OFFICE OF THE CLERK
SUPREME COURT OF THE UNITED STATES

WASHINGTON, D. C. 20543 May 21, 19...71

Case No. 338
O.T. 1970

Receipt is acknowledged of your letter of May 19, 1971 forwarding the invoices for the printing of the Appendix and Supplement in this case. Many, many thanks.

E. ROBERT SEAVER,
Clerk
by
H. Loughran

OFFICE OF THE CLERK
SUPREME COURT OF THE UNITED STATES
WASHINGTON, D. C. 20543

POSTAGE AND FEES PAID
SUPREME COURT OF THE U.S.

OFFICIAL BUSINESS

Richard S. Phillips, Esq.
Hofgren, Wegner, Allen, Stellman
& McCord
20 North Wacker Drive
Chicago, Illinois 60606

*5/19/71
Concep*

May 19, 1971

Mrs. Helen K. Loughran
Office of the Clerk
Supreme Court of the United States
Washington, D. C. 20543

RE: **Blonder-Tongue Laboratories, Inc. v.
University of Illinois Foundation, et al
No. 338, October Term, 1970**

Dear Mrs. Loughran:

* In accordance with your request, I enclose
copies of Gunthorp-Warren invoices L21902 and 22003
for the printing of the appendix in this case. If you
need anything further, please let me know.

Very truly yours,

Richard S. Phillips

RSP:iag

* Enclosure

cc: Mr. R. H. Rines

SUPREME COURT OF THE UNITED STATES
OFFICE OF THE CLERK
WASHINGTON, D. C. 20543

E. ROBERT SEAVER
CLERK OF THE COURT

May 18, 1971

Richard S. Phillips, Esq.
Hofgren, Wegner, Allen
20 North Wacker Drive
Chicago, Illinois 60606

RE: BLONDER-TONGUE LABORATORIES, INC.
v. UNIVERSITY OF ILLINOIS FOUNDATION,
ET AL., No. 338, October Term, 1970

Dear Mr. Phillips:

It would be greatly appreciated if you would forward a duplicate copy of the invoice of the Gunthorp-Warren Printing Company for the printing of the Appendix in this case.

I regret to say that the copy you forwarded previously has been misplaced.

Very truly yours,

E. ROBERT SEAVER, Clerk

By

Helen K. Loughran

(Mrs.) Helen K. Loughran
Assistant Clerk

AIR MAIL

*Xerox copy to
L.S. Riney
5/19/71*

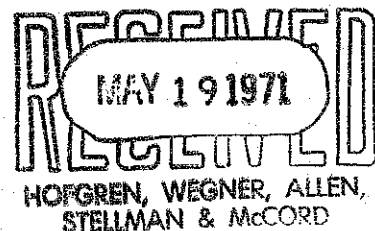



THE GUNTHORP-WARRON PRINTING COMPANY

123 NORTH WACKER DRIVE • CHICAGO 60606

TELEPHONE FINANCIAL 6-1717



SOLD
TO Hofgren, Wegner, Allen, Stellman, & McCord
• 2200 - 20 North Wacker Drive
Chicago, Illinois 60606

SHIPPED TO

F. O. B.

TERMS NET... NO DISCOUNT	DATE SHIPPED 12/4/70	OUR JOB NO. 83-997	YOUR ORDER NO. Phillips	INVOICE DATE 12/23/70	INVOICE NO. L 22003
-----------------------------	-------------------------	-----------------------	----------------------------	--------------------------	------------------------

QUANTITY	DESCRIPTION	UNIT PRICE	AMOUNT
----------	-------------	------------	--------

75 copies

Supplement - U.S. Supreme Court

Blonder-Tongue Laboratories vs.
University of Illinois Foundation

843.35

Postage

9.28

852.63

2/23/71
CH # 6188
\$ 9,805.53



THE GUNTHORP-WARREN PRINTING COMPANY

123 NORTH WACKER DRIVE • CHICAGO 60606

TELEPHONE FINANCIAL 6.1717



SOLD
TO

Hofgren, Wegner, Allen, Stillman & McCord
2200 - 20 North Wacker Drive
Chicago, Illinois 60606

SHIPPED TO

F. O. B.

TERMS NET. NO DISCOUNT	DATE SHIPPED 12/2/70	OUR JOB NO. 83-522	YOUR ORDER NO.	INVOICE DATE 12/17/70	INVOICE NO. L 21902
---------------------------	-------------------------	-----------------------	----------------	--------------------------	------------------------

QUANTITY	DESCRIPTION	UNIT PRICE	AMOUNT
75 copies	Appendix - U.S. Supreme Court Blonder-Tongue Laboratories, Inc. vs. University of Illinois Foundation		8916.38
	Air Freight		<u>36.52</u>
			8952.90



THE GUNTHORP-WARREN PRINTING COMPANY

123 NORTH WACKER DRIVE • CHICAGO 60606

TELEPHONE FINANCIAL 6-1717



SHIPPED TO

SOLD TO Hofgren, Wegner, Allen, Stellman & McCord
 • 2200 - 20 North Wacker Drive
 • Chicago, Illinois 60606
 • Attn: Mr. Richard S. Phillips

F. O. B.

TERMS NET... NO DISCOUNT	DATE SHIPPED	OUR JOB NO.	YOUR ORDER NO.	INVOICE DATE	INVOICE NO.
	12/2/70	83-522	Phillips	12/17/70	L 21902

QUANTITY	DESCRIPTION	UNIT PRICE	AMOUNT
----------	-------------	------------	--------

75 copies

Appendix - U.S. Spreme Court

Blonder-Tongue Laboratories vs.
University of Illinois Foundations

Volume 1

50 Basic Copies-383pp. @ 7.60	2910.80
Covers	15.00
4pp. Index @ 12.50	50.40
14 Plano Exhibits @ 12.00	168.00
231 lines Footnotes (8 or 10 pt.) @ 35¢	80.85
25 Additional Copies-392pp. @ 1.50	588.00
25 Additional Covers @ 20¢	5.00
14 Plano Exhibits @ 1.87½	26.25
Bindery Work on Exhibits	195.00
	<u>4039.30</u>

Volume 11

50 Basic Copies	
Covers	15.00
2pp. Index @ 12.60	25.20
331 Plano Exhibits @ 12.00	3972.00
25 Additional Copies-2pp. @ 1.50	3.00
25 Additional Covers @ 20¢	5.00
331 Plano Exhibits @ 1.87½	620.63
11 hrs. Extra Proofs @ 17.50	192.50
	<u>4877.08</u>

Volume 1
Air Freight

4039.30
36.52

8952.90

May 7, 1971

Alderson Reporting Co., Inc.
300 - 7th, S. W.
Washington, D. C.

Gentlemen:

I would like to secure a copy of the transcript of oral arguments before the Supreme Court in Blonder-Tongue Laboratories, Inc. v. University of Illinois Foundation et al, No. 338, argued January 14, 1971. Please advise the cost.

Very truly yours,

Richard S. Phillips

RSP:iag

Dick: See requests for your action on costs. Can we get a copy of the oral transcript in the Supreme Court, quoted in the decision? RHR

RINES AND RINES

ATTORNEYS AT LAW

NO. TEN POST OFFICE SQUARE

BOSTON, MASSACHUSETTS 02109

DAVID RINES
ROBERT H. RINES

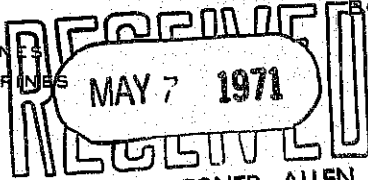

HOFGREN, WEGNER, ALLEN,
STELLMAN & McCORD

CABLE SENIR
TELEPHONE HUBBARD 2-3289

May 5, 1971

Mr. Isaac Blonder
and
Mr. Ben Tongue
Blonder-Tongue Laboratories, Inc.
One Jake Brown Road
Old Bridge, New Jersey 08857

Re: Supreme Court Decision in Blonder-Tongue
Laboratories, Inc. v. University of Illinois
Foundation et al

Dear Ike and Ben:

We have now studied the 38-page decision of the Supreme Court and would give you our preliminary views as follows:

1. This is a land-mark case in patent law, removing possible relitigation abuses of the doctrine of Triplett v. Lowell, but retaining safeguards to patentees who have not had a full and fair trial (as in the case of the BT patent), where courts have not understood the technical issues (our prior experience in the Nyssonnen case) and where the courts did not follow standards for invention set down by the Supreme Court in Graham v. Deere (again, as in the case of Judge Hoffman in connection with the BT patent).
2. In doing the above, the Supreme Court followed the position that we took in the oral argument (see quoting of colloquy with the court on pages 6 and 7) and the moderate position taken by the Department of Justice.
3. The court vacated the complete judgment in this case, meaning that the total decision of Judge Hoffman and the Court of Appeals on all issues has been struck. The Supreme

Mr. Isaac Blonder
Mr. Ben Tongue

Court has also remanded the case in its entirety to Judge Hoffman for the following further proceedings:

- a. After we amend the complaint to plead that the Isbell patent should not be retried since in the Winegard case the University had its full day in court, Judge Hoffman should listen to the University arguments why in the light of this partial over-ruling of Triplett v. Lowell the University should have a second day in court on the Isbell patent.
- b. The Supreme Court has further provided that Blonder-Tongue may "supplement the record" produced in its inadequate trial on all issues to bolster its proofs in connection with both the University suit and the counter claims.
- c. The Supreme Court has offered Judge Hoffman certain legal guide lines to follow. These guide lines are as follows:
 1. We must have a "full and fair chance to litigate the validity", and we must not be deprived "without fault of his own... of crucial evidence or witnesses" (page 20).
 2. If the counter claim shows "fraud or other inequitable conduct" by the patentee, this must be struck down (page 30).
 3. If the counter claim shows an attempt "to enlarge the monopoly of the patent by the expedient of attaching conditions to its use", this must be struck down in the public interest (page 31).

As we preliminarily view this decision, moreover, it appears to smart from our implication that the Supreme Court has been hostile to patentees; and the court has taken this opportunity to say something we have long wanted it to say and mean,

Mr. Isaac Blonder
Mr. Ben Tongue

namely:

"these statutes creating the patent system, expressly sanctioned by the Constitution, represent an affirmative policy choice by Congress to reward inventors..."

"we fully accept Congressional judgment to reward inventors through the patent system" (pages 17 and 18).

Now, what does this mean to Blonder-Tongue?

We must now, through Dick Phillips (whom we are requesting so to proceed by sending a copy of this letter to him) amend the pleadings to plead the defense of Triplett v. Lowell against the Isbell patent. We must also decide what further evidence we can offer in support of all issues to "supplement the record".

Since the matter of whether the partial over-ruling of Triplett v. Lowell applies so that the University should not be given another trial on the Isbell patent can probably be handled by a motion for judgment, we may not have to present additional evidence to supplement the record because you may wish to drop the counter claims (particularly if we have no good additional proof).

We are asking Dick by this letter to explore the prompt payment to Blonder-Tongue of the costs awarded by the Court of Appeals and the costs in the Supreme Court, which under Rule 57 (paragraphs 2 and 3) will include the cost of printing the appendix, the cost of transcript of record, etc. We trust that Dick will proceed on this immediately.

Very truly yours,

RINES AND RINES

By 
Robert H. Rines

RHR/ch

cc:Richard S. Phillips, Esq. ✓
Nelson H. Shapiro, Esq.
Paul J. Foley, Esq.
Julius E. Foster, Esq.

BT Litigation

May 5, 1971

Mr. Robert H. Rines
Rines and Rines
No. Ten Post Office Square
Boston, Massachusetts 02109

RE: UIF v. BT

Dear Bob:

I assume by now you have had an opportunity to read the Supreme Court opinion. You have managed to avoid a total reversal of Triplett v. Lowell. I think the final position of the Court is not wholly unreasonable although there are a few rather wild statements along the line.

I don't know when the mandate from the Supreme Court will reach the district court but will check shortly and keep you advised.

Will you draft an amended answer or should we?

It isn't over yet, but I think the Foundation will have a difficult time showing they did not have a full and fair chance to litigate the validity of the patent in Iowa. I doubt they can show that the Iowa decision did not purport to employ the Graham standards; that the court "wholly failed to grasp" the subject matter or that they were deprived of evidence. I am sure they will try to expand the area of inquiry, however.

Very truly yours,

Richard S. Phillips

RSP:iag

McNENNY, FARRINGTON, PEARNE & GORDON
920 MIDLAND BUILDING
CLEVELAND, OHIO 44115

*Blonder Tongue
Litigation*

May 5, 1971

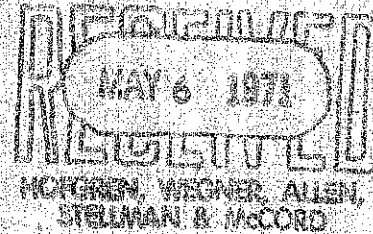

C Robert H. Rines, Esq.
10 Post Office Square - Room 1318
Boston, Massachusetts 02109

Dear Bob:

O
P
Y
I have not yet received a copy of the Supreme Court decision in the log periodic antenna case, but have received a very brief summary of the decision by telephone from a member of the APLA committee that filed an amicus brief. Since Blonder-Tongue's choice as to the position it will now take would no longer appear to have any significant affect on the viability of our patent system, I assume that you are probably going to plead collateral estoppel as authorized by the Supreme Court decision and seek a dismissal of the Complaint of the Foundation on that ground. However, I would greatly appreciate your advising me as soon as possible as to the position to be taken by Blonder Tongue, since that will determine whether I should seek to amend the pleadings of The Finney Company in its case for asserting collateral estoppel against any effort by the Foundation to enforce the Isbell patent against The Finney Company.

Although I would criticize the Supreme Court for not having disposed of at least the major additional issues presented to it, I feel that its disposition of the collateral estoppel issue may turn out to be satisfactory as far as maintaining a viable patent system is concerned. My reaction in that regard could change, of course, when I have an opportunity to actually read the Supreme Court decision.

Sincerely,

JFP:jh

cc: Richard S. Phillips, Esq.

Litigation

May 4, 1971

Mr. Robert H. Rines
Rines and Rines
No. Ten Post Office Square
Boston, Massachusetts 02109

RE: Blonder-Tongue

Dear Bob:

I have not yet seen a copy of the Supreme Court opinion. However, based on the third hand information I have, I understand the case is remanded to Judge Hoffman to hold a hearing to determine whether or not he should have held the trial in the first place.

In a similar situation, Judge Hoffman has taken a very strict attitude regarding the consideration of additional evidence. In *Aqua Chem v. Baldwin-Lima-Hamilton*, 167 USPQ 257, an appeal from the Board of Patent Interferences, he struck the testimony of an expert witness which had not been presented to the Patent Office. The evidence concerned the adequacy of an earlier application to support the claims in interference, a contention which had been made in the Patent Office. However, it appeared that the witness was available at the time the interference testimony was taken and there was no showing that the failure to introduce the evidence was not the result of fraud, bad faith or gross negligence.

The decision suggests that the burden is on the one who offers the new evidence to explain why it was not offered at the earlier proceeding.

We were on the losing side in this case and the client decided not to take an appeal.

Sincerely yours,

Richard S. Phillips

RSP:iag

ULF v BT - Litigation

WSJ - 5/4/71

The Patent Case

In the patent case, the University of Illinois Foundation, which administers patents developed at the university, brought suit against Blonder-Tongue, a small New Jersey concern, for alleged infringement of two patents in the home TV-antenna field. A federal district court found the patents valid and ruled that Blonder-Tongue had infringed.

The U.S. Seventh Circuit Court of Appeals in Chicago upheld the validity of one of the patents, even though another circuit court of appeals, in an earlier case, had held the same patent invalid. The seventh circuit held the second patent invalid.

The Supreme Court reviewed the case to rule on the question of whether an appeals court for one circuit is bound by a prior holding of invalidity of a patent by an appeals court of another circuit. The high court, with an opinion by Justice Byron White, unanimously held that at least in some circumstances one circuit can consider another circuit's finding. The high court remanded the antenna patent case for further proceedings.

Nelson Shapiro

5/3/71

TUL only thing discussed -

Ordinary contract place to stop -

Not fair & lake
Ex contracting circumstances

Q. gave several examples -

Not allowed to present witness

Litigation

LAW OFFICES

MERRIAM, MARSHALL, SHAPIRO & KLOSE

TWO FIRST NATIONAL PLAZA
CHICAGO, ILLINOIS 60670

TELEPHONE
312-346-5750
TELEX 25-3856

CHARLES J. MERRIAM
WILLIAM A. MARSHALL
JEROME B. KLOSE
NORMAN M. SHAPIRO
BASIL P. MANN
CLYDE V. ERWIN, JR.
ALVIN D. SHULMAN
EDWARD M. O'TOOLE
ALLEN H. GERSTEIN

OWEN J. MURRAY
DONALD E. EGAN
NATE F. SCARPELLI
CARL KUSTIN
MICHAEL P. BUCKLO
CARL E. MOORE, JR.
ROBERT D. WEIST
MICHAEL F. BORUN

April 26, 1971

VIA UBT

Richard S. Phillips, Esq.
HOFGREN, WEGNER, ALLEN,
STELLMAN & McCORD
20 North Wacker Drive
Chicago, Illinois 60606

Dear Dick:

Please refer to your letter of April 15, 1971 regarding the costs awarded to Blonder-Tongue by the Court of Appeals.

In view of the imminent decision by the Supreme Court which will probably have some effect on the matter of costs and/or damages, I suggest we wait and wind up the whole proceedings at once rather than piecemeal. I am sure that the unpaid costs cannot be a matter of great moment to Mr. Blonder.

Sincerely yours,

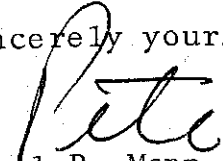

Basil P. Mann

BPM/kd

*Three copies to
R. H. Rieck
J. S. Blonder*

RECEIVED
APR 27 1971
HOFGREN, WEGNER, ALLEN,
STELLMAN & McCORD

April 15, 1971

Mr. Basil P. Mann
Merriam, Marshall, Shapiro & Klose
30 West Monroe Street
Chicago, Illinois 60603

Dear Pete:

I wrote you last December regarding the payment to Blonder-Tongue of \$1787.47 in costs, in accordance with the decision of the court of appeals. We would appreciate your expediting this matter with the Foundation.

Very truly yours,

Richard S. Phillips

RSP:iag

cc: Mr. R. H. Rines
Mr. I. S. Blonder

April 1, 1971

Mr. Isaac S. Blonder
Blonder-Tongue Laboratories Inc.
P. O. Box 664
One Jake Brown Road
Old Bridge, New Jersey 08857

Dear Ike:

Our office manager has called to my attention the fact that it has been more than a month since we have received a payment from you. We have paid the printer for the appendix and brief. This substantial cash outlay which we have made on your behalf causes a serious problem with our cash flow. I would appreciate your early attention to this.

Best wishes,

Richard S. Phillips

RSP:iag

COPY

OFFICE OF THE CLERK
SUPREME COURT OF THE UNITED STATES
WASHINGTON, D.C. 20543

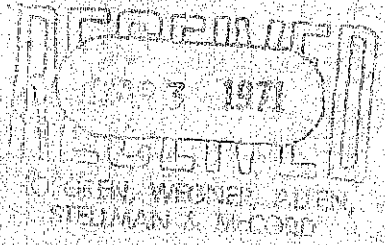

March 1, 1971

Robert H. Rines, Esq.
Rines & Rines
No. Ten Post Office Square
Boston, Mass. 02109

RE: BLONDER-TONGUE LABORATORIES, INC.
v. UNIVERSITY OF ILLINOIS FOUNDATION, ET AL., No. 338, O.T., 1970

Dear Sir:

The Court today entered the following order in the above-entitled case:

The motion of Blumcraft of Pittsburgh opposing motion of Kawneer Company, Inc., for leave to file a brief, as amicus curiae, after argument, is denied.

Very truly yours,

E. Robert Seaver, Clerk

By

E.T. Lyddane
E.T. Lyddane
Assistant Clerk

cc: ✓ Richard S. Phillips, Esq.
Hofgren, Wegner, Allen, Stellman
& McCord

20 North Wacker Dr.
Chicago, Ill. 60608

Charles J. Merriam, Esq.
Merriam, Marshall, Shapiro & Klose
30 West Monroe St.
Chicago, Ill. 60603

Sidney G. Faber, Esq.
Faber, Gerb & Soffen
10 E. 40th St.
New York, N.Y. 10016

Joseph B. Brennan, Esq.
3100 First Nat'l Bank Tower
Atlanta, Ga. 30303

James C. McConnon, Esq.
Paul & Paul
1815 Land Title Bldg.
Philadelphia, Pa. 19110

Ostrolenk,

OFFICE OF THE CLERK
SUPREME COURT OF THE UNITED STATES
WASHINGTON, D. C. 20543

E. ROBERT SEAVER
CLERK OF THE COURT

January 18, 1971

/Richard S. Phillips, Esq.
Hofgren, Wegner, Allen, Stellman
& McCord
20 North Wacker Drive
Chicago, Ill. 60606

RE: BLONDER-TONGUE LABORATORIES, INC.
v. UNIVERSITY OF ILLINOIS FOUNDATION,
ET AL., No. 338, Oct. Term,
1970

Dear Sir:

The Court today entered the following order in
the above-entitled case:

The motion of Kawneer Company, Inc.,
for leave to file a brief, as amicus curiae,
is granted.

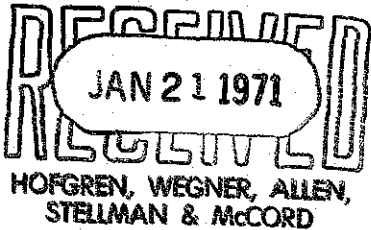

Very truly yours,

E. Robert Seaver, Clerk
By

[Signature]
Assistant Clerk

cc: / Joseph B. Brennan, Esq.
3100 First National Bank Tower
Atlanta, Ga. 30303

AIR MAIL

January 19, 1971

Mr. Robert A. Cesari
89 State Street
Boston, Massachusetts 02109

Dear Mr. Cesari:

Bob Rines has asked that I send you a copy of
* our brief. It is enclosed.

Very truly yours,

Richard S. Phillips

RSP:iag

* Enclosure

cc: Mr. R. H. Rines

The Co.

Robert A. Cesari

89 State St.

Boston 02109

Carol

68 Leonard

David Rine

10 PO

January 15, 1971

Mr. Theodore Anderson
Pendleton, Neuman,
Williams & Anderson
77 West Washington Street
Chicago, Illinois 60602

RE: Blonder-Tongue v. University of
Illinois Foundation et al

Dear Ted:

If you have a spare copy of your amicus brief,
I would appreciate your sending it to me so that I will
have a full set. Thanks very much.

Very truly yours,

Richard S. Phillips

RSP:iag

January 15, 1971

Mr. Jerome M. Berliner
Ostrolenk, Faber, Gerb & Soffen
10 East 40th Street
New York, New York 10016

RE: Blonder-Tongue v. University
Of Illinois Foundation et al

Dear Jerry:

I did not receive a copy of your Supreme Court brief. In order that our file will be complete, I would appreciate your sending me a copy if you have a spare.

Very truly yours,

Richard S. Phillips

RSP:iag

January 15, 1971

Office of the Clerk
Supreme Court of the United States
Washington, D. C. 20543

ATTENTION: Mr. Gullickson

Dear Mr. Gullickson:

RE: Blonder-Tongue v. University of
Illinois Foundation et al
No. 338

I wish to thank you again on behalf of Mr. Rines and myself for your assistance in connection with the exhibits. Having the material readily available in the court room was a great help to us in presenting our argument.

Very truly yours,

Richard S. Phillips

RSP:iag

January 11, 1971

Mr. Donald W. Banner
Borg Warner Corporation
200 South Michigan Avenue
Chicago, Illinois 60603

Dear Don:

* I am returning the APLA brief and appendix.

Thanks very much.

Very truly yours,

Richard S. Phillips

RSP:iag

* Enclosure

COPY

OFFICE OF THE CLERK
SUPREME COURT OF THE UNITED STATES
WASHINGTON, D. C., 20543

E. ROBERT SEAVER
CLERK OF THE COURT

January 11, 1971

RECEIVED
JAN 13 1971
HOFGREN, WEGNER, ALLEN,
STELLMAN & McCORD

Robert H. Rines, Esq.
Rines & Rines
No. 10 Post Office Square
Boston, Mass. 02109

RE: BLONDER-TONGUE LABORATORIES, INC.
v. UNIVERSITY OF ILLINOIS FOUNDATION,
ET AL., No. 338, Oct. Term, 1970

Dear Sir:

The Court today entered the following order in
the above-entitled case:

The motion of the Automatic Electric Company
for leave to file a brief, as amicus curiae, is
granted. The motions of the Automatic Electric
Company and the American Patent Law Association
for leave to participate in the oral argument,
as amicus curiae, are denied. The motion of the
petitioner for additional time for oral argument
is denied.

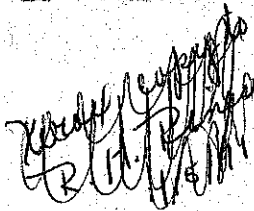

Very truly yours,

cc: Richard S. Phillips, Esq.
Hofgren, Wegner, Allen, Stellman
& McCord
20 North Wacker Drive
Chicago, Ill. 60606

E. Robert Seaver, Clerk
By

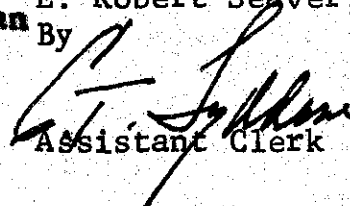

Assistant Clerk

cc/ Charles J. Merriam, Esq.
Merriam, Marshall, Shapiro & Klose
30 West Monroe St.
Chicago, Ill. 60603

AIRMAIL

McNENNY, FARRINGTON, PEARNE & GORDON

920 MIDLAND BUILDING

CLEVELAND, OHIO 44115

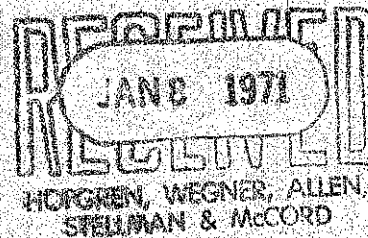

January 7, 1971

C Robert H. Rines, Esq.
10 Post Office Square - Room 1318
Boston, Massachusetts 02109

Dear Bob:

O I have received and read the APLA brief and consider it a magnificent job. The purpose of this letter is merely to suggest that your case against the Isbell patent and for the Blonder et al. patent can be most strongly supported within the framework of the principles espoused by the APLA brief on the matter of obviousness, including the consideration of "unpredictability." I hope you will do your utmost to win on those two patent issues by taking that approach, as the one most likely to succeed while also strengthening the patent system.

P I shall be at the Supreme Court hearing as a spectator and wish you the best of luck.

Sincerely,

John

Y JFP:jh

cc: Richard S. Phillips, Esq.

January 7, 1971

Mr. Robert H. Rines
Rines and Rines
No. Ten Post Office Square
Boston, Massachusetts 02109

Dear Bob:

* I enclose a copy of the motion by Automatic Electric for permission to present an oral argument in opposition to the doctrine of Triplett v. Lowell.

I have sent copies of the Foundation's brief to Pearne and Kulie.

Very truly yours,

Richard S. Phillips

RSP:iag

* Enclosure

January 7, 1971

Mr. John F. Pearne
McNenny, Farrington,
Pearne & Gordon
920 Midland Building
Cleveland, Ohio 44115

Dear John:

* I enclose a copy of the Foundation's brief.

Automatic Electric has requested permission from the court for ten minutes to present an oral argument in opposition to Triplett v. Lowell. I also understand that the APLA is filing a brief and requesting permission to argue; but neither Bob nor I have sent their brief.

I will be at the Crystal City Marriott Monday evening; and Bob and Ike Blonder are arriving on the 13th.

Very truly yours,

Richard S. Phillips

RSP:iag

* Enclosure

January 7, 1971

Mr. Keith J. Kulie
135 South LaSalle Street
Chicago, Illinois 60603

Dear Keith:

* I enclose a copy of the Foundation's brief.

Very truly yours,

Richard S. Phillips

RSP:iag

* Enclosure

CHARLES J. MERRIAM
WILLIAM A. MARSHALL
JEROME B. KLOSE
NORMAN M. SHAPIRO
BASIL P. MANN
CLYDE V. ERWIN, JR.
ALVIN D. SHULMAN
EDWARD M. O'TOOLE
ALLEN H. GERSTEIN
OWEN J. MURRAY
DONALD E. EGAN
NATE F. SCARPELLI
CARL KUSTIN
MICHAEL P. BUCKLO
CARL E. MOORE, JR.
ROBERT D. WEIST
MICHAEL F. BORUN

LAW OFFICES

MERRIAM, MARSHALL, SHAPIRO & KLOSE

THIRTY WEST MONROE STREET
CHICAGO, ILLINOIS 60603

TELEPHONE
312-346-5750
TELEX 25-3856

January 4, 1971

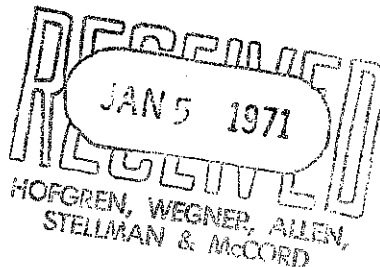

Richard S. Phillips, Esq.
HOFGREN, WEGNER, ALLEN,
STELLMAN & McCORD
20 North Wacker Drive
Chicago, Illinois 60606

Re: Blonder-Tongue v. University
of Illinois Foundation

Dear Dick:

Enclosed is a copy of our brief in the Supreme
Court which was filed today.

Sincerely yours,

Basil P. Mann

BPM/kd
Encl.

January 4, 1971

Mr. Theodore W. Anderson
Pendleton, Neuman,
Williams & Anderson
77 West Washington Street
Chicago, Illinois 60602

RE: Blonder-Tongue Laboratories, Inc. v.
University of Illinois Foundation et al

Dear Ted:

* In accordance with your request, I enclose a copy
of petitioner's brief in the above.

Very truly yours,

Richard S. Phillips

RSP:iag

* Enclosure

cc: Mr. R. H. Rines

6/1
- No.
D. Phillip

LAW OFFICES
LANE, AITKEN, DUNNER & ZIEMS
1828 L STREET, NORTHWEST
WASHINGTON, D. C. 20036

JOSEPH M. LANE
RICHARD L. AITKEN
DONALD R. DUNNER
ROBERT F. ZIEMS
WARREN B. KICE
ANTHONY M. LORUSSO
RONALD P. KANANEN
PHILIP H. GOTTFRIED
WILLIAM E. JACKSON
THOMAS R. BOLAND

(202) 466-8000
CABLE ADDRESS: LADU4Z
TELEX: 24436

January 4, 1971

E. Robert Seaver, Esq.
Clerk, Supreme Court of
the United States
Washington, D.C.

Re: Blonder-Tongue Laboratories, Inc.
v. University of Illinois Foundation
etc., No. 338, October Term, 1970

Sir:

Enclosed herewith are forty (40) copies of
(1) Brief for the American Patent Law Association as Amicus
Curiae and (2) Appendix to Brief for the American Patent
Law Association as Amicus Curiae in the above-identified
case.

We are also enclosing herewith for the Court's
use a copy of "The Crisis of Law, Patents & Trade Secrets",
by Professor Irving Kayton (Patent Resources Group, Washington,
D.C. (1970)). This text is cited at several points in the
American Patent Law Association amicus brief and is likely
not available in the Court's library.

Respectfully submitted,



DONALD R. DUNNER
Counsel for Amicus Curiae,
American Patent Law Association

PENDLETON, NEUMAN, WILLIAMS & ANDERSON
ATTORNEYS AND COUNSELORS
77 WEST WASHINGTON STREET
CHICAGO, ILLINOIS 60602

COPY

December 31, 1970

Robert H. Rines, Esquire
Rines & Rines
Ten Post Office Square
Boston, Massachusetts 02109

Re: Blonder-Tongue Laboratories, Inc.
v.
University of Illinois Foundation, et al.

Dear Mr. Rines:

Enclosed are three copies of the Motion of Automatic Electric Company to file a Brief Amicus Curiae and the Brief. This combined Motion and Brief is being filed in the Supreme Court today.

We would greatly appreciate having one of the printed copies of your brief if you have one that you can spare.

Very truly yours,

PENDLETON, NEUMAN, WILLIAMS & ANDERSON

By

Theodore W. Anderson

TWA:LM

Enclosures

CC: Messrs. Richard S. Phillips

Paul J. Foley

Nelson H. Shapiro

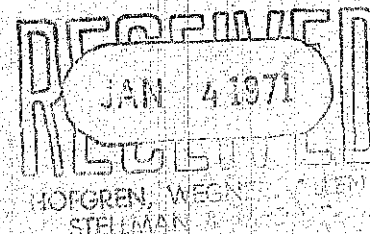

December 30, 1970

Basil P. Mann, Esq.
Merriam, Marshall, Shapiro & Klose
30 West Monroe
Chicago, Illinois 60603

Dear Pete:

In accordance with our telephone conversation, I enclose a copy of the order by Judge Fairchild dated March 9, 1970, ordering that Blonder-Tongue recover \$1,787.47 from the Foundation. We would appreciate your arranging for payment of this amount.

Very truly yours,

Richard S. Phillips

RSP/rmb
Enclosure

Chronology

1/30/59

1/4 Report # 1

3/31/59

1/4 Report # 2

4/30/59

1/4 Rep # 2 published

5/3/60

Iskell filed

9/30/60

Mayer filed

1/23/62

Chicago Trib article - says Mayer disclosed Summer 1959

5/31/62

1st JPD license

Ads

App. Pa
542

DX37 - Electronic Technician. 8/66 - 11 pages (p 544)

DX42

- 546 B4 Radio & TV Weekly. 2/10/64 - photo formula
- 547 B4A "
- 548 B101 JFD literature
- 549 reprint from Chicago Trib. - 1/23/62
- 551 reprint from Popular Science - 1963
- 552 reprint from Chicago Trib. - 1/23/62
- 553 B102 Reprint from Radio-Electronics 6/63
- 557 B103 Reprint from Radio & TV Weekly - 2/64
- 559 B104 UEP → JFD 10/14/64 - Same as A 540
- 561 B105 JFD → SWS - 4/21/64
- 563 B106 LPV - Space Age ---
- 564 B107 LOOK & d
- 565 B108 6db filter -- Sales Literature
- 566 B109 Ad or sales lit w/ gain curves.
- 568 B111 JFD → SWS - 4/21/64
- 571 B113 Ad - U.I. Nat. Res. Lab
- 573 J6 Ad - No other antennas (1965)

Correspondence re ads

DK 30 - A 528

App Pg.

528 Finkel ltr → Smith - 7/27/64
530 JFD ltr → Colvin - 8/12/64
533 JFD ltr → Colvin - 9/14/64
535 UJA ltr → JFD - 9/25/64
537 JFD ltr → Colvin - 10/5/64
540 UJA ltr → JFD - 10/14/64

561 DK42-B-105 - JFD → Smith - 4/14/64. admit no
product covered by a patent.
(This ltr replies to a letter of 4/25/64 from
SBS)

568 B111 - JFD → Smith - 4/21/64

570 B112 SBS → JFD - 7/17/64
Threaten cancellation

SUPREME COURT OF THE UNITED STATES
OFFICE OF THE CLERK
WASHINGTON, D. C. 20543

E. ROBERT SEAVER
CLERK OF THE COURT

December 28, 1970



Richard S. Phillips, Esq.
Hofgren, Wegner, Allen, Stelman
and McCord
20 North Wacker Drive
Chicago, Illinois 60606

RE: BLONDER-TONGUE LABORATORIES, INC. v.
UNIVERSITY OF ILLINOIS FOUNDATION,
ET AL., No. 338, Oct. Term, 1970

Dear Mr. Phillips:

Two attorneys will be permitted to argue for each side in addition to the argument of the Solicitor General in the above-entitled case. The petitioners will open with either one or two attorneys and they should save time out of their 40 minutes for rebuttal. The Solicitor General's argument of 20 minutes will follow, and then two attorneys will present argument for the respondents for 40 minutes. One attorney will be permitted to rebut for the petitioners in whatever time is reserved out of the 40 minutes allotted to the petitioners.

The division of time among counsel will be determined by counsel, and this office should be notified of such division on the morning of the date of argument.

Very truly yours,

E. ROBERT SEAVER, Clerk

By

E. P. Cullinan
Chief Deputy

EPC:jmh

cc: Robert H. Rines, Esq.

December 22, 1970

The Honorable Erwin N. Griswold
Solicitor General of the United States
Department of Justice
Washington, D. C. 20530

Re: Blonder-Tongue Laboratories, Inc. v.
University of Illinois Foundation
No. 338, October Term, 1970

Dear Sir:

The request in your letter of December 18, 1970, has been granted and you will be allotted 20 minutes time to participate in the oral argument in this case.

By copies of this letter, petitioner and respondent are advised that an additional 10 minutes has been allotted to each of them to respond to the argument of the Solicitor General, as outlined in his letter of December 18, 1970.

Very truly yours,

E. ROBERT SEAVER, Clerk

By

Michael Rodak, Jr.
Deputy Clerk

cc: all counsel

December 28, 1970

Touche, Ross & Company
60 Park Place
Newark, New Jersey

Re: Blonder-Tongue Laboratories, Inc.

Gentlemen:

We are assisting Robert H. Rines in connection with the lawsuit between Blonder-Tongue Laboratories, Inc. and the University of Illinois Foundation and JFD. This matter is presently pending before the United States Supreme Court and argument in it is scheduled for January 1971.

If you need further information concerning this, I suggest that you check directly with Mr. Rines.

As of October 31, 1970 there was owing us for fees \$1,080.81. This has since been paid.

Very truly yours,

Richard S. Phillips

RSP/rmb
CC - Mr. Frank E. Smith



BLONDER-TONGUE LABORATORIES INC.

ONE JAKE BROWN ROAD/OLD BRIDGE, NEW JERSEY 08857/(201) 679-4000

DECEMBER 14, 1970

HOFGREN, WEGNER, ALLEN, STILLMAN, & McCORD
20 NORTH WACKER DRIVE
CHICAGO, ILLINOIS 60606

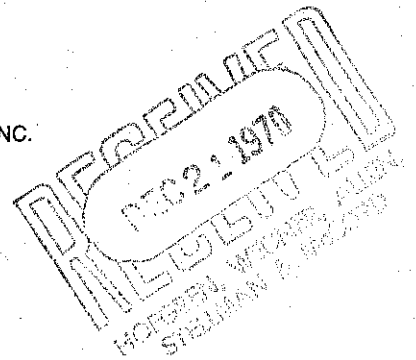

GENTLEMEN:

OUR AUDITORS, TOUCHE, ROSS & COMPANY, 60 PARK PLACE, NEWARK, NEW JERSEY, ARE MAKING AN EXAMINATION OF OUR FINANCIAL STATEMENTS FOR THE YEAR ENDED OCTOBER 31, 1970. IN CONNECTION THEREWITH, PLEASE FURNISH THEM WITH THE FOLLOWING INFORMATION WITH RESPECT TO OUR COMPANY OF WHICH YOU HAVE KNOWLEDGE:

1. NATURE AND CURRENT STATUS OF ANY LITIGATION, INCOME OR OTHER TAX PROCEEDINGS, OR OTHER PROCEEDINGS BY GOVERNMENTAL AGENCIES, LIKELY OR PENDING, IN WHICH WE ARE INVOLVED IN ANY WAY.
2. AMOUNTS OF DIRECT OR INDIRECT CONTINGENT ASSETS OR LIABILITIES ARISING FROM SUCH MATTERS, AND YOUR SETIMATE OF THE ULTIMATE RECOVERY BY OR COST TO THE COMPANY.
3. ANY JUDGMENTS OR SETTLEMENTS RENDERED (AND THE AMOUNTS INVOLVED) EITHER IN FAVOR OR AGAINST THE COMPANY, AS A RESULT OF SIGNIFICANT CLAIMS, LAWSUITS, OR PROCEEDINGS BY GOVERNMENTAL AGENCIES DURING THE PAST YEAR.
4. ANY MAJOR TRANSACTIONS OR CHANGES IN THE MODE OF OPERATION THAT HAVE COME TO YOUR ATTENTION DURING THE PAST YEAR, WHETHER CONSUMMATED, PROPOSED OR UNDER DISCUSSION, WHICH MIGHT AFFECT OUR FINANCIAL POSITION.

OUR AUDITORS WILL APPRECIATE A LETTER FROM YOU AT YOUR EARLIEST CONVENIENCE.

ALSO, IF ANY EVENTS SIMILAR TO THOSE LISTED ABOVE COME TO YOUR ATTENTION BETWEEN OCTOBER 31, 1970 AND JANUARY 15, 1971, PLEASE INFORM OUR AUDITORS BY TELEPHONE AT #622-7100 AS SOON AS POSSIBLE.

YOURS VERY TRULY,

BLONDER - TONGUE LABORATORIES INC.

FRANK E. SMITH
CONTROLLER

FES:MD

Answer as of 10/31/70
\$ 1080.81
Now Paid



20 years of quality television products

Federal Bldg
219 S. Dearborn

27th Floor

Federal Storage & Moving Co.
EA 7-7300

December 22, 1970

Clerk of the United States Court of Appeals
Seventh Circuit
219 South Dearborn Street
Chicago, Illinois 60604

Re: UNIVERSITY OF ILLINOIS FOUNDATION v.
BLONDER-TONGUE v.
JFD ELECTRONICS CORPORATION
No. 17153

Dear Sir:

The above case is pending before the United States Supreme Court on a Petition for Certiari, Case 338 October Term, 1970. It has been scheduled for argument on January 14.

We wish transmitted to the Supreme Court, to be available at the time of the argument and for the Court's consideration the documentary exhibits of all three parties. We also wish the following physical exhibits transmitted to the Supreme Court:

PLAINTIFF EXHIBIT

10 Blonder-Tongue Golden Dart Antenna

DEFENDANT'S EXHIBITS

24 Antenna model

29 Transmission line (attached to Plaintiff's Exhibit 10)

JFD EXHIBITS

5C Strain relief member

8D Heslin antenna

13 Mayes antenna

14 chart

26A Blonder-Tongue Ranger 3 antenna

26D Carton for Blonder-Tongue Ranger 3 antenna.

Clerk of the Court of Appeals
December 22, 1970
Page 2

We shall be happy to assist in packing the physical exhibits for shipment. I understand that Silverman and Cass, local associates for JFD, have a shipping crate in which JFD Exhibit 8D was sent to Chicago.

Very truly yours,

Richard S. Phillips

RSP/rmb

CC - Ostrolenk, Faber, Gerb & Soffen
Silverman & Cass
Merriam, Marshall, Shapiro & Klose
Mr. Robert Rines

December 21, 1970

Harry J. Roper, Esq.
Pendleton, Neumann, Williams & Anderson
77 West Washington
Chicago, Illinois 60602

Re: BLONDER-TONGUE LABORATORIES, INC. v.
UNIVERSITY OF ILLINOIS FOUNDATION
ET AL

Dear Mr. Roper:

This confirms our conversation. On behalf of
Blonder-Tongue Laboratories, I refuse to consent to the
filing of a brief in the above on behalf of Automatic
Electric Co.

Very truly yours,

Richard S. Phillips

RSP/rmb

OFFICE OF THE CLERK
SUPREME COURT OF THE UNITED STATES
WASHINGTON, D. C., 20543

E. ROBERT SEAVER
CLERK OF THE COURT

December 21, 1970

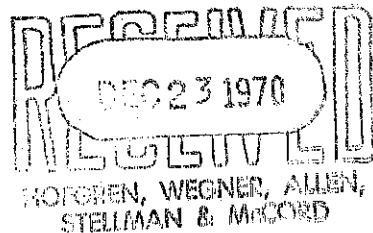

Richard S. Phillips, Esq.
Hofgren, Wegner, Allen, Stellman
& McCord
20 North Wacker Drive
Chicago, Ill. 60606

RE: BLONDER-TONGUE LABORATORIES, INC. v.
UNIVERSITY OF ILLINOIS FOUNDATION,
ET AL., No. 338, Oct. Term, 1970

Dear Sir:

The Court today entered the following order in
the above-entitled case:

The motion of The Finney Company for leave to
file a brief, as amicus curiae, is granted. The
motion of The Finney Company for leave to participate
in oral argument, as amicus curiae, is denied. The
motion of respondent, University of Illinois Foun-
dation, to allow additional time for oral argument is
denied.

Very truly yours,

cc: Myron C. Cass, Esq.
Silverman & Cass
105 West Adams St.
Chicago, Ill. 60603

E. Robert Seaver, Clerk
By

Assistant Clerk

cc: Harold F. McNenny, Esq.
McNenny, Farrington, Pearne & Gordon
920 Midland Bldg.
Cleveland, Ohio 44115

AIRMAIL

December 21, 1970

Office of the Clerk
Supreme Court of the United States
Washington, D.C. 20543

Re: BLONDER-TONGUE LABORATORIES, INC. v.
UNIVERSITY OF ILLINOIS FOUNDATION, ET AL

Dear Sir:

The argument for petitioner will be presented by
Robert H. Rines.

Very truly yours,

Richard S. Phillips

RSP/rmb
EC - Mr. Rines

December 18, 1970

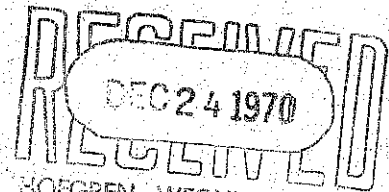

HOFGREN, WEGNER, ALLEN,
STELLMAN & McCORD

E. Robert Seaver, Esq.
Clerk, Supreme Court of the
United States
Washington, D.C.

Re: Blonder-Tongue Laboratories, Inc.
v. University of Illinois Foundation
etc., No. 338, October Term, 1970

Dear Mr. Seaver,

In this case, the Court requested counsel for the parties to discuss the following question in their briefs:

Should the holding of Triplett v. Lowell, 297 U.S. 638, that a determination of patent invalidity is not res judicata, as against the patentee in subsequent litigation against a different defendant, be adhered to?

It now appears that the briefs filed by the parties will raise no issue with respect to this question. Both parties take the position that Triplett v. Lowell, should not be overruled.

In this situation, it appears that it may be helpful to the Court if the Solicitor General files a brief which undertakes to examine the problem raised by the Court. Accordingly, I have authorized the preparation of a brief amicus curiae which will discuss the question raised by the Court.

In addition, I request an opportunity to participate in the oral argument, and ask that 20 minutes be allocated for the purpose.

Very truly yours,

Wald

cc: ROBERT H. RINES
DAVID RINES
Rines & Rines
Ten Post Office Square
Boston, Massachusetts 02109

RICHARD S. PHILLIPS
Hofgren, Wegner, Allen,
Stellman & McCord
20 North Wacker Drive
Chicago, Illinois 60606

PAUL J. FOLEY
Belen & Foley
425 13th Street, N.W.
Washington, D. C. 20004

NELSON H. SHAPIRO
Shapiro & Shapiro
Washington Building
15th and New York Avenue, N.W.
Washington, D. C. 20005

CHARLES J. MERRIAM
WILLIAM A. MARSHALL
BASIL P. MANN
Merriam, Marshall, Shapiro
& Klose
30 West Monroe Street
Chicago, Illinois 60603

SIDNEY G. FABER
Ostrolenk, Faber, Gerb & Soffen
10 East 40th Street
New York, New York 10016

MYRON C. CASS
Wilverman & Cass
105 West Adams Street
Chicago, Illinois 60603

HAROLD F. McNENNY
JOHN F. PEARNE
McNenny, Farrington, Pearne & Gordon
930 Midland Building
Cleveland, Ohio 44115

WALTHER E. WYSS
Mason, Kolehmainen, Rathburn & Wyss
20 North Wacker Drive
Chicago, Illinois 60606

SUPREME COURT OF THE UNITED STATES
OFFICE OF THE CLERK
WASHINGTON, D. C. 20543

E. ROBERT SEAVER
CLERK OF THE COURT

December 18, 1970

Richard S. Phillips, Esq.
Hofgren, Wegner, Allen, Stellman
and McCord
20 North Wacker Drive
Chicago, Illinois 60606

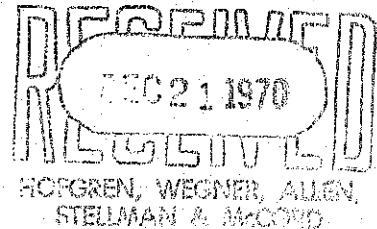

RE: BLONDER-TONGUE LABORATORIES, INC. v.
UNIVERSITY OF ILLINOIS FOUNDATION,
ET AL., No. 338, Oct. Term, 1970

Dear Mr. Phillips:

Counsel in the above-entitled case should be present for oral argument on Thursday, January 14, 1971.

Kindly advise by return air mail who will present the argument for the petitioner in this case.

Very truly yours,

E. ROBERT SEAVER, Clerk

By

E. P. Cullinan
Chief Deputy

EPC:jmh
Enclosure

cc: Robert H. Rines, Esq.
Ten Post Office Square
Boston, Massachusetts 02109

AIR MAIL

Physical Ex. to Sep Ct.

Pitt's Ex.

BT 10 - Golden Dart Antenna

DPSE Ex.

BT 24 - Antenna model

BT 29 - Transmission Line - (Attached to P-10)

JFD Ex

BT 26A - Antenna - BT Ranger 3.

BT 26D - Carton for BT Ranger 3

JFD 5C - Strain relief

JFD 8D - Nest in antenna

JFD 13 - Mayer antenna - (Shawin. C.U. Courier - 5/2/61 - JFD 12)

JFD 14 - Chart re C.S. - Blue paper

LAW OFFICES
MASON, KOLEHMAINEN, RATHBURN & WYSS

20 NORTH WACKER DRIVE
SUITE 3200
CHICAGO, ILLINOIS 60606

WAINO M. KOLEHMAINEN
COUNSEL
—
AREA CODE 312
TELEPHONE 346-1677

RICHARD D. MASON
M. HUDSON RATHBURN
WALTHER E. WYSS
REGINALD K. BAILEY
WILLIS J. JENSEN
ROBERT L. ROHRBACK
WARREN D. MCPHEE
CLEMENS HUFMANN
ANDREW J. BOOTZ
PHILIP C. PETERSON
PHILIP M. KOLEHMAINEN
JAMES A. SPROWL
JOSEPH KRIEGER

December 16, 1970

CABLE ADDRESS: MAKRAW

Richard S. Phillips, Esquire
Hofgren, Wegner, Allen, Stellman & McCord
20 North Wacker Drive
Chicago, Illinois 60606

Re: Blonder-Tongue Laboratories, Inc.
v. University of Illinois Foundation et al

Dear Mr. Phillips:

Pursuant to our telephone conversation, it is my understanding that on behalf of your client, Blonder-Tongue Laboratories, Inc., petitioner in the above-identified case now pending before the United States Supreme Court, you refuse to consent to the filing by Kawneer Company, Inc. of an amicus curiae brief under Rule 42 of the Supreme Court rules.

If you agree to the foregoing understanding, please signify by signing and returning the enclosed copy of this letter.

Sincerely,

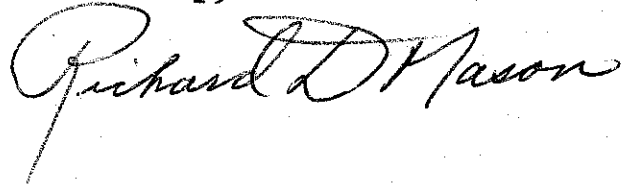

RDM:la
Encl.

LAW OFFICES
MASON, KOLEHMAINEN, RATHBURN & WYSS

20 NORTH WACKER DRIVE
SUITE 3200
CHICAGO, ILLINOIS 60606

RICHARD D. MASON
M. HUDSON RATHBURN
WALTHER E. WYSS
REGINALD K. BAILEY
WILLIS J. JENSEN
ROBERT L. ROHRBACK
WARREN D. MCPHEE
CLEMENS HUFMANN
ANDREW J. BOOTZ
PHILIP C. PETERSON
PHILIP M. KOLEHMAINEN
JAMES A. SPROWL
JOSEPH KRIEGER

WAINO M. KOLEHMAINEN
COUNSEL
—
AREA CODE 312
TELEPHONE 346-1677

CABLE ADDRESS: MAKRAW

December 16, 1970

Richard S. Phillips, Esquire
Hofgren, Wegner, Allen, Stellman & McCord
20 North Wacker Drive
Chicago, Illinois 60606

Re: Blonder-Tongue Laboratories, Inc.
v. University of Illinois Foundation et al

Dear Mr. Phillips:

Pursuant to our telephone conversation, it is my understanding that on behalf of your client, Blonder-Tongue Laboratories, Inc., petitioner in the above-identified case now pending before the United States Supreme Court, you refuse to consent to the filing by Kawneer Company, Inc. of an amicus curiae brief under Rule 42 of the Supreme Court rules.

If you agree to the foregoing understanding, please signify by signing and returning the enclosed copy of this letter.

Sincerely,

Richard D. Mason

RDM:la
Encl.

I hereby agree to the above understanding.

Date: December 17, 1970

Richard S. Phillips
Richard S. Phillips

December 16, 1970

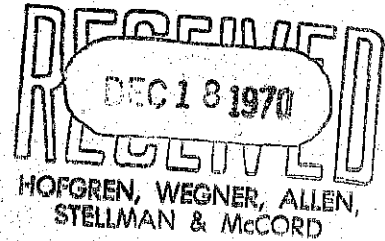

Donald R. Dunner, Esquire
Lane, Aitken, Dunner & Ziems
1828 L Street, Northwest
Washington, D.C. 20036

Re: Blonder-Tongue v. University of
Illinois Foundation and JFD Electronics,
No. 338 United States Supreme Court

Dear Mr. Dunner:

Thank you for your letter of December 10.

We are pleased to enclose the signed Consent to the appearance as amicus curiae of the American Patent Law Association in this cause.

From Bill Hulbert we gather that the issues to which you are addressing the views of the American Patent Law Association include Triplett v. Lowell and the standards of obviousness under Graham v. Deere.

While we were informed that it was the decision of the Patent Law Association not to discuss the fraud in the Patent Office aspect, we wonder whether this would not be an appropriate time to get the association views with regard to whether such fraud or deception should bar relief for a patentee under the "unclean hands" or other doctrine.

In this case, the Court of Appeals found that a misleading affidavit was filed, that resulted in the issuance of the patent (which then was copiously used in the market place) but ignored the matter of whether this conduct gave the patentee any standing in a Court of Equity, particularly where the affidavit involved the inventions of both of the patents in suit.

Turning, now, to the matter of obviousness, we hope that your discussions will include what we regard as the shameful treatment of the Blonder counterclaim patent which was dismissed on the mere fiat of "obviousness" without any of the findings of Graham v. Deere.

Donald R. Dunner

December 16, 1970

We have just had another classic case of this character in the Second Circuit where the District Court made the most copiously detailed findings of fact as required in Graham v. Deere, including specifics as to what those skilled in the art were doing over the years in question in trying to solve their problem; but the Court of Appeals, in a few page decision, merely disagreed and considered the invention obvious without overturning any of the District Court's detailed findings as clearly erroneous and without even attempting to make findings of its own of the nature required by Graham v. Deere.

We enclose a Xerox copy of our brief for rehearing (General Radio Company v. Kepco, Inc.).

We think it is important for the Supreme Court to know the roughshod treatment of "obviousness" in many of the lower courts today.

The undersigned will be in Washington on Thursday and Friday of this week, if you have any questions, reachable in care of Nelson Shapiro, Esquire, 640 Washington Building, 15th and N. Y. Avenue, N.W., Washington, D.C. (Tel. 202 Sterling 3-0498).

Very truly yours,

RINES AND RINES

RHR/bd
Encs.

By _____

cc: William R. Hulbert, Esq.
Isaac S. Blonder
Richard S. Phillips, Esq.
Nelson H. Shapiro, Esq.
Paul J. Foley, Esq.
Dr. Donald B. Sinclair

December 14, 1970

Mr. Robert H. Rines
Rines and Rines
No. Ten Post Office Square
Boston, Massachusetts 02109

RE: Blonder-Tongue

Dear Bob:

Dick Mason of Mason, Kolehmainen, Rathburn & Wyss (who happen to be local counsel for John Pearne in the Finney suit) wants to file an amicus brief advocating reversal of Triplett v. Lowell. For the sake of the record, he is writing me a letter to which I will reply refusing to consent.

Very truly yours,

Richard S. Phillips

RSP:iag

STATE OF ILLINOIS, }
COUNTY OF COOK. }

ss. L Arado being first duly

sworn, deposes and says that he served three copies of the

Supplement to Volume II

in the above entitled cause, as per statute herein made and provided, on

Merriam, Marshall, Shapiro & Klose
30 West Monroe Street
Chicago, Illinois 60603

Ostrolenk, Faber, Gerb & Soffen
10 East 40th Street
New York, New York 10016

this 4th day of December, A. D. 1970

L Arado

Subscribed and sworn to before me this 4th
day of December, A. D. 1970

Carl R. Berg
Notary Public.

SUPREME COURT OF THE UNITED STATES
OFFICE OF THE CLERK
WASHINGTON, D. C. 20543

E. ROBERT SEAVER
CLERK OF THE COURT

December 3, 1970

Richard S. Phillips, Esquire
Hofgren, Wegner, Allen
20 North Wacker Drive
Chicago, Illinois 60606

Re: Blonder-Tongue Lab., Inc. v. Univ. of
Ill., etc., et al., No. 338, O. T. 1970

Dear Mr. Phillips:

Your application for an extension of time to file the petitioner's brief and appendix in the above-entitled case has been granted and the time extended to and including December 7, 1970.

The time for filing a supplement to the appendix has been granted and the time extended to and including December 14, 1970.

Very truly yours,

E. Robert Seaver, Clerk

By

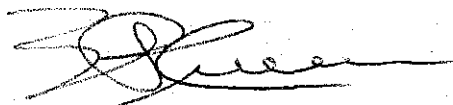

E. P. Cullinan
Chief Deputy

EPC:lsr

cc: R. H. Rines, Esq.
W. A. Marshall, Esq.
Silverman & Cass

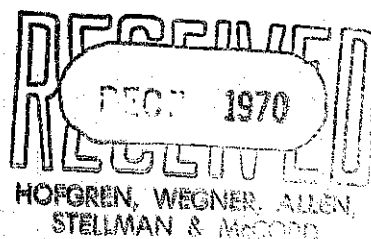

November 30, 1970

Office of the Clerk
Supreme Court of the United States
Washington, D. C. 20543

RE: Blonder-Tongue Laboratories, Inc. v.
University of Illinois Foundation et al
No. 338 -- October Term, 1970

Dear Sir:

Petitioner, Blonder-Tongue Laboratories, Inc., hereby applies for an extension of time to file its brief and the single appendix in the above, to and including Monday, December 7. Final printing and binding of the brief and appendix is presently being done by The Gunthorp-Warren Printing Company, Chicago, Illinois. Petitioner's counsel has been advised by the printer that they should complete the work Tuesday, December 1. It is anticipated that the brief and appendix will be placed in the mail to the Court on December 1. However, the extension of time is requested to insure that the brief and appendix will not be filed late in the event of some unexpected difficulty in the final stages of printing and binding, or an unusual delay in the mail.

November 30, 1970

Petitioner further requests an additional extension of time to and including December 14, 1970, to file a supplement to the appendix containing reproductions of three documentary exhibits. Respondent, JFD Electronics Corporation, requested that the exhibits be included in the appendix. Inadvertently the originals of the exhibits were not delivered to the printer with the other material for the appendix. The oversight was discovered in preparing the index for the appendix, and the exhibits were promptly sent to the printer. Rather than delay binding of the major portion of the appendix, the exhibits are being reproduced in a supplementary volume. The extension of time for the filing of the supplement to the appendix should not delay respondents in their preparation of reply briefs.

Very truly yours,

Richard S. Phillips
Counsel for Petitioner

RSP:iag

cc: Mr. R. H. Rines
Mr. W. A. Marshall
Mr. S. G. Faber

November 30, 1970

Clerk
United States Supreme Court
Washington, D. C.

RE: Blonder-Tongue Laboratories, Inc.
v. University of Illinois Founda-
tion et al
No. 338 -- October Term, 1970

Dear Sir:

Please enter my appearance as counsel for
petitioner, Blonder-Tongue Laboratories, Inc., in the
above.

Very truly yours,

Richard S. Phillips

RSP:iag

cc: Mr. R. H. Rines
Mr. W. A. Marshall
Mr. S. G. Faber

November 10, 1970

Mr. Robert H. Rines
Rines and Rines
No. Ten Post Office Square
Boston, Massachusetts 02109

Dear Bob:

I have given our material to the printer this morning. We still don't have a designation from the Foundation or JFD.

I heard third hand that John Pearne will not argue in favor of Triplett v. Lowell.

How is the brief coming?

Very truly yours,

Richard S. Phillips

RSP:iag

November 9, 1970

Mr. Robert P. Cummins
Hume, Clement, Hume & Lee
5150 First National Bank Plaza
Chicago, Illinois 60670

Dear Bob:

* I enclose a set of the briefs and the petition for certiorari in the Blonder-Tongue case. You may keep the reply brief for defendant and the petition for certiorari. Please return the others as we are running short on copies.

Very truly yours,

Richard S. Phillips

RSP:iag

* Enclosure

November 5, 1970

Mr. Robert H. Rines
Rines and Rines
No. Ten Post Office Square
Boston, Massachusetts 02109

Dear Bob:

I talked with Keith Kulie on November 3. The Supreme Court has not yet acted on the Foundation's petition in the Winegard suit.

Very truly yours,

Richard S. Phillips

RSP:iag



**U.S. DEPARTMENT OF COMMERCE
Patent Office**

Address Only: COMMISSIONER OF PATENTS
Washington, D.C. 20231

November 4, 1970

Messrs. Robert H. Rines
and Richard S. Phillips
Hofgren, Wegner, Allen, Stellan
& McCord
20 North Wacker Drive
Chicago, Illinois 60606

Gentlemen:

Careful consideration has been given all of the matters referred to in your letter of October 29, 1970, forwarding a copy of the petition for a writ of certiorari in *Blonder-Tongue Laboratories, Inc. v. University of Illinois Foundation*. The conclusion has been reached that the case is not one in which it would be appropriate for the Patent Office to express any view as an amicus curiae.

Very truly yours,

S. Wm. Cochran

S. Wm. Cochran
Solicitor

*Work copy to
R.S. Rines
11/9/70*

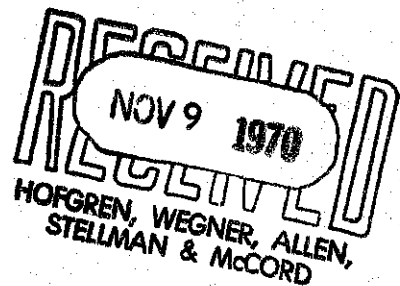

United States Court of Appeals

For the Seventh Circuit

Chicago, Illinois 60604

No. 17653 September Term, 19.....

University

vs.

Blonder Tongue

Received from the Clerk copies of the as Counsel

for

Hatzgren, Wagner, Allen, Stellman & McCord

Louise A. Hecht

DATE: *Nov 3-70*

..... Pleadings

..... Transcripts

..... Depositions

..... Exhibits

..... Other (Specify)

*9 Stems of Exhibits
Part of Record*

Please sign and return to the Clerk of the United States Court of Appeals for the Seventh Circuit, Chicago, Illinois

November 3, 1970

Mr. Robert H. Rines
10 Post Office Square
Boston, Massachusetts 02109

Dear Bob:

On October 30th, we received the September issue of the Journal of the Patent Office Society. It contains an extensive discussion of the IN REM INVALIDITY.

Very truly yours,

Richard S. Phillips

RSP:MMI

MEMO FROM

MARY R. CANAVAN

2043 CRYSTAL PLAZA DRIVE
ARLINGTON, VIRGINIA 22202

(703) 521-3531

BARBARA J. HENDLEY
ASSOCIATE

November 2, 1970

Dear Mr. Phillips:

The envelope enclosed with your letter of October 29 was hand carried to S. W. Cochran, Office of the Solicitor, today.

Mary R. Canavan

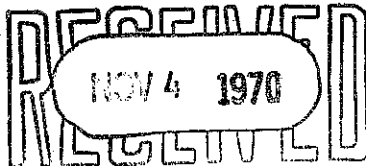

HOFGREN, WEGNER, ALLEN,
STELLMAN & McCORD

October 29, 1970

Mrs. Mary R. Canavan
2043 Crystal Plaza Drive
Arlington, Virginia 22202

Dear Mrs. Canavan:

* I enclose an envelope which I would like you
to deliver to S. W. Cochran, Office of the Solicitor,
Room 11C04 CP 3.

Very truly yours,

Richard S. Phillips

RSP:iag

* Enclosure

October 29, 1970

S. W. Cochran, Esq.
Office of the Solicitor
United States Patent Office
Washington, D. C. 20231

RE: Blonder-Tongue Laboratories, Inc. v.
University of Illinois Foundation
and JFD Electronics Corp.
U. S. Supreme Court, No. 338
Certiorari Granted October 20, 1970

Dear Mr. Cochran:

Confirming our telephone discussion, we are dictating this letter at the office of Mr. Richard Phillips, who is counsel with us in the above cause.

* Enclosed is a copy of our petition and we invite particular attention to the second question contained on pages 3 and 4 and discussed on pages 9 through 12 of the petition.

This situation is actually aggravated by virtue of the fact that the prior invention of Isbell was admittedly a fact known to Mayes and counsel, though it was not communicated to the Patent Office. Mayes, indeed, was a co-worker in the University antenna laboratory and was stimulated by Isbell's work. Counsel, moreover, were the same individuals who were then prosecuting the earlier Isbell patent application.

The court of appeals recognized the impropriety of making an affirmative statement of half truths in an affidavit, in the knowledge that if the patent examiner knew the whole truth, this would sustain and not overcome the rejection.

As you are undoubtedly aware, and as we discussed over the telephone, many courts (we suspect in their hostility

October 29, 1970

to patents) are going much farther than seems reasonable in terms of the obligations of lawyers practicing before the Patent Office (we might refer you, for example, to the Beckman Instruments case cited on page 14 of our petition).

Although we feel there is no excuse for the kind of misconduct involved in our case, we are fearful that the Supreme Court might go too far in this matter and in a way that might make it uncomfortable for the Patent Office and the practitioners before that bar.

We, accordingly, feel strongly that the view of the Patent Office in terms of a sensible approach to this problem from the point of view of practice and procedure would be most helpful, particularly now that the Supreme Court is apparently going to make a definitive ruling on the responsibilities in this connection.

In telephonically checking with Solicitor General Griswold, we were informed that the Solicitor General's office would consider as persuasive any expression of interest in an amicus participation from the Patent Office, though the Solicitor General's office would be free to decide ultimately whether it would or would not participate.

Should the Patent Office have interest, and we think it ought to seize this opportunity so that mischief is not created on either side, we then suspect that the Justice Department will want to have something to say about the related issues of what should be the sanctions under circumstances of such abuse in the Patent Office when the patent gets to court; i.e., questions of enforceability under equitable doctrines, such as unclean hands, and questions of unfair competition and antitrust violation in connection with competition-restraining use of a patent obtained by such improper conduct.

We would be delighted to visit with you and Commissioner Schuyler to discuss this further, not just from the partisan point of view of representing our client, but, with our client's permission, from the broader point of view of our mutual responsibilities as officers of the Patent Bar, the Patent Office and the courts.

Cordially,

Robert H. Rines

Richard S. Phillips

RHR:iag
* Enclosure

bcc: Nelson Shapiro, Esq.

OFFICE OF THE CLERK
SUPREME COURT OF THE UNITED STATES
WASHINGTON, D. C., 20543

E. ROBERT SEAVER
CLERK OF THE COURT

October 29, 1970

RECEIVED

NOV 2 1970

RE McNENNY, FARRINGTON,
PEARNE & GORDON

NOV 5 1970

MASON, ROLEMAN, BATHURST & WYSS
20 NORTH WACKER DRIVE
CHICAGO 6, ILLINOIS

Robert H. Rines, Esq.
Ten P. O. Square
Boston, Massachusetts 02109

Charles J. Marriam, Esq.
30 West Monroe Street
Chicago, Illinois 60603

Sidney G. Faber, Esq.
10 East 40th Street
New York, N. Y. 10016

Harold P. McNenny, Esq.
920 Midland Building
Cleveland, Ohio 44115

RE: BLONDER-TONGUE LABORATORIES, INC.
v. UNIVERSITY OF ILLINOIS FOUNDATION,
ET AL., No. 338, Oct. Term, 1970

Gentlemen:

I have been instructed to advise you that the Court on November 9 will enter the following order in the above-entitled case:

"In addition to the questions tendered in the petition for certiorari, the parties in this case are requested to address themselves to the following questions in their briefs and oral arguments:

1. Should the holding of Triplett v. Lowell, 237 U.S. 638, that a determination of patent invalidity is not res judicata as against the patentee in subsequent litigation against a different defendant, be adhered to?

Robert H. Rines, Esq.
Charles J. Merriam, Esq.
Sidney G. Faber, Esq.
Harold F. McNenny, Esq.

- 2 -

October 29, 1970

2. If not, does the determination of
invalidity in the Winegard litigation
bind the respondents in this case?"

Very truly yours,

E. ROBERT SEAVER, Clerk

By 

E. P. Cullinan
Chief Deputy

EPC:jmh

LAW OFFICES

Silverman & Cass

PATENTS · TRADEMARKS · COPYRIGHTS

105 W. ADAMS STREET · CHICAGO, ILLINOIS, U. S. A. 60603

I. IRVING SILVERMAN
MYRON C. CASS
SIDNEY N. FOX
GERALD R. HIBNICK, IND. BAR ONLY
HERBERT J. SINGER
NORBERT MELBER

TELEPHONE 726-6006
AREA CODE 312
CABLE: SILCAS

October 27, 1970

Our Ref. 166,418

Richard S. Phillips, Esq.
Hofgren, Wegner, Allen, Stellman and McCord
20 North Wacker Drive
Chicago, Illinois 60606

Re: UIF v. B-T v. JFD

Dear Dick:

I relayed your message regarding Bob Rines being in Chicago on Thursday in connection with designating the contents of the Appendix in the Appeal to the Supreme Court. Jerry Berliner advised that I have no authority to deal with you on that problem at this time. The reason for this is that principal counsel is Sidney J. Faber and Jerry Berliner is working with him. Consequently, you or Bob Rines will be required to contact Sid Faber and/or Jerry Berliner with regard to this Appendix matter.

Yours very truly,

SILVERMAN & CASS



Myron C. Cass

MCC/gm

cc: William A. Marshall, Esq.

*10/28/ - called
Berliner - told him we
would write them or
call Friday*

*Xerox copy to
R. J. Rines
10/28/70*

RECEIVED
OCT 28 1970
HOFGREN, WEGNER, ALLEN,
STELLMAN & McCORD

RINES AND RINES
NO. TEN POST OFFICE SQUARE, BOSTON

October 26, 1970

Office of the Clerk
Supreme Court of the United States
Washington, D.C. 20543

Attention: E. Robert Seaver, Clerk

Re: Blonder-Tongue Laboratories, Inc. v.
University of Illinois Foundation,
No. 338, October Term, 1970

Dear Mr. Seaver:

In response to your letter of October 20, 1970,
we enclose the additional docketing fee of \$50 in connection
with the above-entitled cause.

Very truly yours,

RINES AND RINES

By _____

RHR/bd
Enc.

cc: Richard S. Phillips
Ben H. Tongue

C
O
P
Y

RECEIVED
OCT 28 1970
HOFORN, WEGNER, ALLEN,
STELLMAN & McCORD

October 27, 1970

Mr. Robert H. Rines
Rines and Rines
No. Ten Post Office Square
Boston, Massachusetts 02109

Dear Bob:

Keith Kulie advised me this morning that the
Supreme Court did not act yesterday on the Foundation's
petition in the Winegard suit.

Very truly yours,

Richard S. Phillips

RSP:iag

cc: Mr. J. F. Pearne

October 26, 1970

Mr. Robert H. Rines
Rines and Rines
No. Ten Post Office Square
Boston, Massachusetts 02109

RE: UIF v. BT v. JFD

Dear Bob:

I talked with John Pearne today. He would like to know whether you propose to argue the question presented by his amicus brief supporting the petition for certiorari, relating to logical experimentation and predictability. If you plan to argue this point, he will probably not seek to file an amicus brief on the merits. However, if you do not plan to argue the question, he may file an argument on behalf of the Finney company.

I told him we would try to resolve this question on Thursday and to discuss it with him then.

Very truly yours,

Richard S. Phillips

RSP:iag

October 23, 1970

Mr. Robert H. Rines
Rines and Rines
No. Ten Post Office Square
Boston, Massachusetts 02109

Dear Bob:

* I enclose a copy of the letter from the Supreme Court and its enclosures which I borrowed from Bill Marshall. We don't have much time.

Very truly yours,

Richard S. Phillips

RSP:iag

* Enclosure

cc: Mr. J. F. Pearne - This letter doesn't show that you received a copy so I thought you might like to see it.

October 23, 1970

Mr. Myron C. Cass
Silverman & Cass
105 West Adams Street
Chicago, Illinois 60603

Dear Mike:

* I find that I have an ample supply of copies of the Blonder-Tongue reply brief in the Court of Appeals, but that I do not have any extras of the main brief. I enclose a copy of the reply brief and my copy of the main brief. Please return the main brief at your convenience.

Very truly yours,

Richard S. Phillips

RSP:iag

* Enclosures

Handwritten initials

FREEMAN, SCHMETTERER, FREEMAN & SALZMAN

ATTORNEYS AND COUNSELLORS AT LAW

THIRTY SEVENTH FLOOR

ONE NORTH LA SALLE STREET

CHICAGO, ILLINOIS 60602

LEE A. FREEMAN
JACK B. SCHMETTERER
LEE A. FREEMAN, JR.
JERROLD E. SALZMAN
DONALD P. COLLETON

AREA CODE 312
TELEPHONE 782-7281

October 21, 1970

Mr. Richard S. Phillips
20 North Wacker Drive
Chicago, Illinois 60606

Dear Mr. Phillips:

Thank you very much for so promptly
sending me a copy of your brief in the Blonder-
Tonque Laboratories case.

Sincerely,

Donald P. Colleton
Donald P. Colleton

DPC:lk

RECEIVED
OCT 22 1970
HOFREN, WEGNER, ALLEN,
STELLMAN & McCORD

October 20, 1970

Mr. William A. Marshall
Merriam, Marshall, Shapiro & Klose
30 West Monroe Street
Chicago, Illinois 60603

RE: UIF v. BT v. JFD

Dear Bill:

This confirms my telephone call proposing to you that we stipulate that the preparation of the Appendix may be deferred in accordance with Supreme Court Rule 36.4. I would appreciate an early reply from you indicating whether this is satisfactory with you as we have a very short period to designate the Appendix in the event you decide not to stipulate that it may be deferred.

Very truly yours,

Richard S. Phillips

RSP:iag

cc: Mr. R. H. Rines
Mr. M. C. Cass

OFFICE OF THE CLERK
SUPREME COURT OF THE UNITED STATES
WASHINGTON, D. C., 20543

E. ROBERT SEAVER
CLERK OF THE COURT

October 20, 1970

Charles J. Merriam, Esq.
30 West Monroe Street
Chicago, Illinois 60603

RE: BLONDER-TONGUE LABORATORIES, INC.
v. UNIVERSITY OF ILLINOIS FOUNDATION,
ET AL., No. 338, October Term, 1970

Dear Sir:

Confirming our telegram of yesterday the Court took the following action in the above case:

"The motion of The Finney Company for leave to file a brief, as amicus curiae, is granted. The petition for a writ of certiorari is also granted."

I enclose a memorandum describing the time requirements and procedures under the Rules.

Very truly yours,

E. ROBERT SEAVER, Clerk
By

Helen K. Loughran
(Mrs.) Helen K. Loughran
Assistant Clerk

AIR MAIL

cc: Sidney G. Faber, Esq.

usual
L.P.
Slant on Seav. Cl.
B.B.
Put all
petitions & replies
in it.

MEMORANDUM to Counsel in Cases granted Review on October 19, 1970

Your attention is called particularly to Supreme Court Rules 17, 26, 36 and 39 which apply to the time for the preparation of the record in the form of a Single Appendix and for the filing of briefs on the merits. Copies of these Rules are available from the Clerk and they also are printed in 398 U.S. 1009; 90 S.Ct. 2273; 49 F.R.D. 613; 26 L. Ed 2d following p. 577, p. II and 38 LW 4516. See commentaries in 90 S.Ct. 2337; 49 F.R.D. 679; and Vol. 38 LW 3501.

Unless expedited, some of the cases granted review on October 19 will be calendared for argument in the January 18 session of the Court. This means deadlines provided by the Rules must be met and counsel cannot assume extensions of time will be granted. The Single Appendix and the petitioner's or appellant's brief will be due 45 days from the date of grant, namely December 3. The respondent's, or appellee's brief will be due 30 days thereafter. Rule 36(4) permits the deferral of the filing of the Single Appendix by stipulation of counsel or order of the Court. However, this provision should be used sparingly and only when there is a bulky record which may be reduced in size by a narrowing of the issues in the briefs.

The responsibility for preparing and printing the record in the form of a Single Appendix is placed upon counsel for petitioner or appellant and the attached "Memorandum re Printing" should be followed as closely as possible. It is anticipated that in most instances the contents of the Single Appendix will be agreed upon by the parties. The parties should remember that the entire record is always available to the Court for reference and examination. In the absence of agreement, counsel for the petitioner or appellant must designate the portions of the record to be printed by October 29, and counsel for respondent or appellee must cross-designate by November 9. Since the Single Appendix must be printed by December 3 these dates must be met.

In order to aid the Clerk in administering the Rules, counsel for all parties are requested to inform the Clerk on the date agreement is reached on the contents of the Single Appendix, or in the absence of agreement, the Clerk should be informed on the date that they designate and cross-designate for printing. Also counsel for the petitioner or appellant are requested to inform the Clerk when the Single Appendix is sent to the printers.

If the record was not filed at the time of the docketing of the case, the clerk of the lower court has been requested to certify and transmit the record to this office, under Rule 16(6) or 25(1).

The Clerk and his staff are ready and willing to provide aid and advice on the application of the Rules to each case.

Telephone: Area Code 202 - Executive 3-1640, Extension 315.

OFFICE OF THE CLERK
SUPREME COURT OF THE UNITED STATES
Washington, D. C. 20543

MEMORANDUM RE PRINTING

To assist counsel who are called upon to print Single Appendices under Rule 36, the following suggestions are made:

1. There is enclosed a sample cover to show the appropriate form and color. If the case is on appeal rather than certiorari, the last two lines should indicate when the appeal was docketed and when jurisdiction was noted or postponed. The line preceding should recite - Appeal from the (name of court). The names of counsel should not appear on the cover.
 2. Rule 36(1) requires that the Single Appendix contain:
 - "(1) the relevant docket entries in the proceeding below;
 - (2) any relevant pleading, charge, finding or opinion;
 - (3) the judgment, order or decision in question; and
 - (4) any other parts of the record to which the parties wish to direct the Court's particular attention."
- The Single Appendix should be arranged so that the various documents appear chronologically to the extent possible.
3. Rule 36(6) requires the printing of an appropriate index at the beginning of the Single Appendix.
 4. If no docket entries appear in the record, counsel for the petitioner or appellant should prepare as a substitute a chronological list of the important dates on which pleadings were filed, hearings held and orders entered. The provision of Rule 36(1) for the printing of the docket entries, requires only the printing of entries relating to substantial matters unless a procedural step is germane to the issues presented.
 5. The name of the Court involved should appear at the beginning of each item printed in the Single Appendix.
 6. The title of the case should be printed at the beginning of the first item and the opinions and judgments should likewise carry the title. The title need not be printed on any other papers but a parenthetical note should be inserted - (Title omitted in printing).
 7. Jurats and certificates or affidavits of service may be omitted and an appropriate parenthetical note printed in its stead - (Jurat omitted in printing), (Certificate, or affidavit of service omitted in printing).
 8. Any deletions not specifically noted should be indicated by asterisks.
 9. All opinions and judgments should be printed in full and no deletions made.
 10. In order that testimony reprinted in a Single Appendix may be checked against the original copy, the page at which it appeared in the transcript should be printed in brackets. See Rule 36(6).
 11. The size of type, type page and over-all page are covered by Rule 39(1). If a process other than typographical printing is used, it is not necessary to "justify" the right hand margin.

October 20, 1970

Mr. Donald P. Colleton
Freeman, Schmetterer, Freeman & Salzman
One North LaSalle Street
Chicago, Illinois 60602

Dear Mr. Colleton:

I am replying to your letter to Mr. Allen regarding the University of Illinois Foundation v. Blonder-Tongue Laboratories. Mr. Allen died a year and a half ago.

* I enclose a copy of our main brief in the Court of Appeals. I believe this includes all the arguments that we made at one time or another with regard to the antitrust issues.

Incidentally, there is a conflict between the Seventh and Eighth Circuits with regard to validity of Isbell patent 3,011,168; and the Supreme Court has just granted certiorari. I do not know yet whether we will be permitted to argue the antitrust questions in the Supreme Court.

Very truly yours,

Richard S. Phillips

RSP:iag

* Enclosure

FREEMAN, SCHMETTERER, FREEMAN & SALZMAN

ATTORNEYS AND COUNSELLORS AT LAW

THIRTY SEVENTH FLOOR

ONE NORTH LA SALLE STREET

CHICAGO, ILLINOIS 60602

October 19, 1970

AREA CODE 312
TELEPHONE 782-7281

LEE A. FREEMAN
JACK B. SCHMETTERER
LEE A. FREEMAN, JR.
JERROLD E. SALZMAN
DONALD P. COLLETON

Mr. John Rex Allen
20 North Wacker Drive
Chicago, Illinois

Re: University of Illinois Foundation v.
Blonder-Tonque Laboratories, Inc. v.
J.F.D. Electronics Corp.

Dear Mr. Allen:

We are presently involved in an anti-trust case which raises issues similar to those presented in the captioned case and would appreciate receiving from you any briefs that you may have filed in connection with that case.

Thank you for your cooperation.

Sincerely,

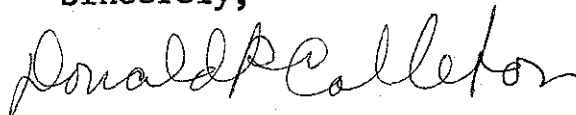

Donald P. Colleton

DPC:jc

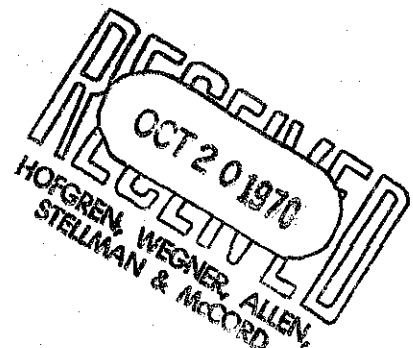

October 14, 1976

Mr. Robert H. Rines
Rines and Rines
No. Ten Post Office Square
Boston, Massachusetts 02109

Dear Bob:

We have Potter's Supreme Court report for October 12. No action was taken in the Blonder-Tongue petition although several which were filed after it were denied. For some reason there is no listing by Potter for the petition filed by the Foundation in the Winegard suit.

Very truly yours,

Richard S. Phillips

RSP:iag

cc: Mr. J. F. Pearne
Mr. W. E. Wyss
Mr. K. J. Kulie

C. T. G. et al.

PRICE, CUSHMAN, KECK & MAHIN
LAW OFFICES
134 SOUTH LA SALLE STREET
CHICAGO, ILLINOIS 60603
TELEPHONE RANDOLPH 6-9000
AREA CODE 312

CABLE ADDRESSES
"HAMSCOTT" "CHAO"

FILE NO.

October 1, 1970

Richard S. Phillips, Esquire
Hofgren, Wegner, Allen, Stellman & McCord
20 North Wacker Drive
Chicago, Illinois 60606

Dear Mr. Phillips:

Thank you kindly for providing us with a copy of
your petition for certiorari for Blonder-Tongue.

Very truly yours,



Robert F. Semmer

RFS:gk

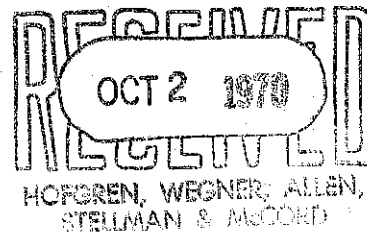

September 28, 1970

Mr. Robert Semmer
Price, Cushman, Keck & Mahin
134 South LaSalle Street
Chicago, Illinois 60603

Dear Mr. Semmer:

* In accordance with our telephone conversation,
I enclose a copy of the petition for certiorari on behalf
of Blonder-Tongue.

Very truly yours,

Richard S. Phillips

RSP:iag

* Enclosure

Blonde Tongue Pot/Cat

Bob Sommer

Price Cushman, Keck + Mohr

Rn 1700

134 S. LaSalle -

LAW OFFICES

HOFGREN, WEGNER, ALLEN, STELLMAN & McCORD

20 NORTH WACKER DRIVE

CHICAGO 60606

file

TELEPHONE:
FINANCIAL 6-1630
AREA CODE 312

JOHN REX ALLEN
1945-1969

AXEL A. HOFGREN
ERNEST A. WEGNER
WILLIAM J. STELLMAN
JOHN B. McCORD
BRADFORD WILES
JAMES C. WOOD
STANLEY C. DALTON
RICHARD S. PHILLIPS
LLOYD W. MASON
TED E. KILLINGSWORTH
CHARLES L. ROWE
W. E. RECKTENWALD
DILLIS V. ALLEN
WM. A. VAN SANTEN
RONALD L. WANKE
LOUIS A. HECHT

August 12, 1971

RECEIVED

AUG 16 1971

RINES AND RINES
NO. TEN POST OFFICE SQUARE, BOSTON

RECEIVED

AUG 16 1971

RINES AND RINES
NO. TEN POST OFFICE SQUARE, BOSTON

Mr. Robert H. Rines
Rines and Rines
No. Ten Post Office Square
Boston, Massachusetts 02109

Dear Bob:

*

I enclose a copy of a notice received from the court today. The admonition that counsel should be ready for trial did not seem proper for our situation. I have talked with Tony Brice, Judge Hoffman's clerk, to find out what they had in mind. Apparently this order form is one which is sent to all cases on the active calendar and, since ours is back on that calendar, we got a notice. Tony says to disregard the statement about being ready for trial and that if Judge Hoffman wishes additional evidence or argument in connection with our motions, he will let me know by phone before the 13th.

I plan on attending court on the 13th to see what happens. It is possible that Judge Hoffman will rule on the motions at that time.

If you should be in the vicinity, I would be pleased to have you join me.

Very truly yours,

Deck

Richard S. Phillips

RSP:iag

*

Enclosure

cc: Mr. I. S. Blonder

UNITED STATES DISTRICT COURT, NORTHERN DISTRICT OF ILLINOIS
EASTERN DIVISION

RSP ✓
JWP

Name of Presiding Judge, Honorable JULIUS J. HOFFMAN

Cause No. 66 C 567

Date AUG 10 1971

Title of Cause University of Illinois Foundation, v.
Blonder-Tongue Laboratories, Inc.

Brief Statement
of Motion

The rules of this court require counsel to furnish the names of all parties entitled to notice of the entry of an order and the names and addresses of their attorneys. Please do this immediately below (separate lists may be appended).

Names and
Addresses of
moving counsel

Representing

Names and
Addresses of
other counsel
entitled to
notice and names
of parties they
represent.

Count
431-9400

Reserve space below for notations by minute clerk

ON COURT'S MOTION, CAUSE WILL
BE ADDED TO THE TRIAL CALL ON **SEP 13 1971** **10:00 a.m.**

COUNSEL REQUIRED TO BE READY FOR TRIAL

Judge Hoffman

RECEIVED
AUG 12 1971
HOFFMAN, WEGNER, ALLEN,
STELLMAN & McCORD

Hand this memorandum to the Clerk.
Counsel will not rise to address the Court until motion has been called.

LAW OFFICES

file

AXEL A. HOFGREN
ERNEST A. WEGNER
WILLIAM J. STELLMAN
JOHN B. McCORD
BRADFORD WILES
JAMES C. WOOD
STANLEY C. DALTON
RICHARD S. PHILLIPS
LLOYD W. MASON
TED E. KILLINGSWORTH
CHARLES L. ROWE
W. E. RECKTENWALD
DILLIS V. ALLEN
W. A. VAN SANTEN
RONALD L. WANKE
LOUIS A. HECHT

HOFGREN, WEGNER, ALLEN, STELLMAN & McCORD

20 NORTH WACKER DRIVE
CHICAGO 60606

TELEPHONE
FINANCIAL 6-1630
AREA CODE 312
JOHN REX ALLEN
1945-1969

July 7, 1971

RECEIVED

JUL 12 1971

Mr. Robert H. Rines
Rines and Rines
No. Ten Post Office Square
Boston, Massachusetts 02109

RINES AND RINES
TEN POST OFFICE SQUARE, BOSTON

RE: University of Illinois Foundation
v. Blonder-Tongue v. JFD

Dear Bob:

I have talked with Keith Kulie and reread the Wine-
gard decisions since writing you last Friday. Keith did not
set up a declaratory judgment counterclaim in the Winegard
suit. They did, however, make the affirmative defense that
"the patent" was invalid. It seems to me this put all the
claims in issue even though the Foundation had not asserted
three of them.

Judge Stephenson mentioned claims 6, 7 and 8, which
were not asserted, at only one point in his decision. He did
not refer to the Isbell claims in the section of the decision
finding the patent invalid. In fact, he concluded that "the
disclosure" of the patent lacked non-obviousness. Similarly,
the Court of Appeals affirmed without in any way limiting
their decision to the claims which had been asserted by the
Foundation at the trial.

I have written the Clerk of the District Court in
Iowa for a certified copy of the Winegard answer and hope to
have it for the hearing before Judge Hoffman if Merriam tries
to press this point.

Very truly yours,

Richard S. Phillips

Richard S. Phillips

RSP:iag

cc: Mr. J. F. Pearne
Mr. Keith Kulie

Memo for File

10/7/71

file

David Rines' thought on the article that appeared in the Journal of the Patent Office Society.

Comments on Mr. Kahn's article "BLONDER TONGUE AND THE SHAPE OF FUTURE PATENT LITIGATION"

On pages 581 to 87 of the September, 1971 Volume 53, No. 9 issue of the Journal of the Patent Office Society. The situation that Mr. Kahn discusses is not restricted to patent litigation. It occurs in every case where after litigation has been completed, a decision of a higher court as controlling of the litigation is handed down. The party who feels ~~xxx~~ that this higher court decision is controlling is enabled to file a petition for rehearing.

The petition ~~ix~~ for rehearing is granted and a decision is rendered in accordance with the principles established by the higher court decision.

In this particular case, Judge Hoffman had rendered his decision and no rehearing was necessary because the case was under appeal and ~~w~~ it was within the province of the Court of Appeals to reverse Judge Hoffman based on the Iowa decision.

The Court of Appeals did not do so and the Supreme Court corrected the error.

A case of mine of some years ago may be of interest. I had two interferences pending in the Patent Office. I won one of these interferences both before the Interference Examiner ~~and~~ on the Board of Appeals and the opposing party took the case into the Court under Section 4915 now 35 U.S.C. 145. I won the Court also.

That disposed of one of the interferences. What about the other? The other had gone through the stage of taking testimony; we filed our briefs and the case was ready for argument. It never reached the stage of argument. I filed a motion for judgment on the grounds of res judicata. The motion was granted.

On page 587, Mr. Kahn makes two points. I agree with both. The time to plead the Iowa judgment was anytime after March 1969 when the 8th circuit decision became final. The decision in the Monsanto case was premature.

Mr. Kahn makes a number of arguments such, for example, that under this reasoning a court may go through the process of trying a case and deciding it and had been compelled to throw away others' work and decide on the basis of res judicata or something similar. The arguments apply also in other litigation in patent suits.

There is no more reason why Judge Hoffman should not have been compelled to reopen the case after the Iowa decision became final that other judges are compelled to do likewise in similar situations.

DR/ch

October 12, 1971

(Dictated October 2, 1971)

Mr. Isaac Blonder
and
Mr. Ben Tongue
Blonder-Tongue Laboratories, Inc.
One Jake Brown Road
Oldbridge, New Jersey 08857

Dear Ike and Ben:

Prior to leaving for Europe, we scanned over Judge Hoffman's decision.

We presume that Dick Phillips will have sent you a copy of the same, but if not, please call Carol.

Succinctly stated, Judge Hoffman has ruled in our favor against the University of Illinois Foundation's assertion of the Isbell patent and the Mayes and Carroll patent.

The nature of this ruling is somewhat muddy except that the judgement provides that the Mayes and Carroll patent is invalid and void in law and that the Isbell patent which was found invalid in University of Illinois Foundation v. Weingard cannot be asserted against Blonder-Tongue Laboratories, Inc.

The wording of the preceding paragraph could be used in a news release, but we suggest that you telephone Dick Phillips with your proposed language if you feel you wish such a release.

The Judge has taken the position that since the Supreme Court did not comment upon the counter-claim (though it did reverse the whole decision in the 7th circuit) he would treat matters as if his dismissal of the counter-claim was still in force.

From the practical point of view, we certainly are very much satisfied with the result and think we ought to let matters rest and not try to relitigate.

Mr. Isaac Blonder
Mr. Ben Tongue

TWO

Our own Blonder patent really served yeoman's service in allowing us to raise up a bona fide counter-claim and, as you will recall, is the reason we filed that particular case in the first place; so it is no loss to abandon efforts to try to reassert that patent.

We are, of course, most delighted with the result and feel that the University of Illinois Foundation will have little chance of reversing this on appeal, should it decide to appeal.

We can now wish you success in your antenna efforts free of future harassment.

We would ask that, in the future, before you decide to adopt novel technical principles evolved outside your company that we explore the matter prior to a fait accomplis.

Cordially,

RINES AND RINES

By _____
Robert H. Rines

RHR/ch

LAW OFFICES

HOFGREN, WEGNER, ALLEN, STELLMAN & McCORD

20 NORTH WACKER DRIVE

CHICAGO 60606

AXEL A. HOFGREN
ERNEST A. WEGNER
WILLIAM J. STELLMAN
JOHN B. McCORD
BRADFORD WILES
JAMES C. WOOD
STANLEY C. DALTON
RICHARD S. PHILLIPS
LLOYD W. MASON
TED E. KILLINGSWORTH
CHARLES L. ROWE
W. E. RECKTENWALD
DILLIS V. ALLEN
WM. A. VAN SANTEN
RONALD L. WANKE

TELEPHONE
FINANCIAL 6-1630
AREA CODE 312

JOHN REX ALLEN
1945-1969

October 1, 1971

RECEIVED

OCT 4 1971

RINES AND RINES
NO. TEN POST OFFICE SQUARE, BOSTON

Mr. Robert H. Rines
Rines and Rines
No. Ten Post Office Square
Boston, Massachusetts 02109

Dear Bob:

* I enclose a copy of the order Judge Hoffman entered today releasing the supersedeas bond. We will have the bond cancelled as soon as possible. I have been in touch with Basil Mann of Merriam's office again regarding the costs. He is raising a question of whether half the costs in the Supreme Court should be paid by JFD. I hope to straighten this out today or early next week and secure payment of the costs shortly.

Very truly yours,



Richard S. Phillips

RSP:iag

* Enclosure

cc: Mr. B. H. Tongue (*)

LAW OFFICES

HOFGREN, WEGNER, ALLEN, STELLMAN & McCORD

20 NORTH WACKER DRIVE
CHICAGO 60606

AXEL A. HOFGREN
ERNEST A. WEGNER
WILLIAM J. STELLMAN
JOHN B. McCORD
BRADFORD WILES
JAMES C. WOOD
STANLEY C. DALTON
RICHARD S. PHILLIPS
LLOYD W. MASON
TED E. KILLINGSWORTH
CHARLES L. ROWE
W. E. RECKTENWALD
DILLIS V. ALLEN
W. A. VAN SANTEN
RONALD L. WANKE

TELEPHONE
FINANCIAL 6-1630
AREA CODE 312

JOHN REX ALLEN
1945-1969

September 29, 1971

RECEIVED
OCT. 4 1971
RINES AND RINES
NO. TEN POST OFFICE SQUARE, BOSTON

Mr. Robert H. Rines
Rines and Rines
No. Ten Post Office Square
Boston, Massachusetts 02109

Dear Bob:

* I enclose two copies of Judge Hoffman's memorandum and judgment. There is apparently a typographic error which I have noted on page 5. We have called this to the Judge's attention and I anticipate that he will correct it.

I plan to present a stipulated motion for an order releasing the supersedeas bond Friday. Judge Hoffman did not award costs to any party, either at the conclusion of the trial in 1968, or in the judgment now entered. However, I hope to have the Foundation pay the costs awarded by the Court of Appeals and the Supreme Court shortly. If they continue to resist, I will go to the clerk for an order.

Very truly yours,

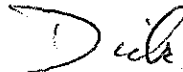

Richard S. Phillips

RSP:iag

* Enclosures

IN THE UNITED STATES DISTRICT COURT
FOR THE NORTHERN DISTRICT OF ILLINOIS
EASTERN DIVISION

THE UNIVERSITY OF ILLINOIS FOUNDATION,

Plaintiff and
Counterclaim Defendant,

- v -

BLONDER-TONGUE LABORATORIES INC.,

Defendant and
Counterclaimant,

- v -

JFD ELECTRONICS CORPORATION,

Counterclaim Defendant.

RECEIVED
OCT 4 1971
RINES AND RINES
No. TEN POST OFFICE SQUARE BOSTON

Civil Action

No. 66 C 567

M O T I O N

Now comes defendant, Blonder-Tongue Laboratories, Inc.,
by its attorneys and moves the Court for an order to release the
supersedeas bond filed July 26, 1968.

Richard S. Phillips

September 30, 1971.

Of Counsel:

Robert H. Rines
David Rines
Rines and Rines
No. Ten Post Office Square
Boston, Massachusetts 02109

Hofgren, Wegner, Allen, Stelman & McCord
20 North Wacker Drive
Chicago, Illinois 60606

The motion for release of the supersedeas bond is
agreed to.

UNIVERSITY OF ILLINOIS FOUNDATION

_____, 1971.

By _____

JFD ELECTRONICS CORPORATION

_____, 1971.

By _____

IN THE UNITED STATES DISTRICT COURT
FOR THE NORTHERN DISTRICT OF ILLINOIS
EASTERN DIVISION

THE UNIVERSITY OF ILLINOIS FOUNDATION,)
)
) Plaintiff and)
) Counterclaim Defendant,)
)
 - v -)
)
) BLONDER-TONGUE LABORATORIES INC.,)
)
) Defendant and)
) Counterclaimant,)
)
 - v -)
)
) JFD ELECTRONICS CORPORATION,)
)
) Counterclaim Defendant.)

ORDER RELEASING SUPERSEDEAS BOND

An order of this Court having been entered September 27, 1971, giving judgment for the defendant,

IT IS HEREBY ORDERED THAT defendant's motion for release of the supersedeas bond be granted.

Judge, United States District Court

_____, 1971.

LAW OFFICES

HOFGRN. WEGNER. ALLEN. STELLMAN & McCORD

20 NORTH WACKER DRIVE

CHICAGO 60606

TELEPHONE
FINANCIAL 6-1630
AREA CODE 312

JOHN REX ALLEN
1945-1969

AXEL A. HOFGRN
ERNEST A. WEGNER
WILLIAM J. STELLMAN
JOHN B. McCORD
BRADFORD WILES
JAMES C. WOOD
STANLEY C. DALTON
RICHARD S. PHILLIPS
LLOYD W. MASON
TED E. KILLINGSWORTH
CHARLES L. ROWE
W. E. RECKTENWALD
DILLIS V. ALLEN
WM. A. VAN SANTEN
RONALD L. WANKE
LOUIS A. HECHT

September 29, 1971

Mr. Ben H. Tongue
Blonder-Tongue Laboratories Inc.
P/O Box 664
One Jake Brown Road
Old Bridge, New Jersey 08857

Dear Ben:

- * I enclose a copy of Judge Hoffman's memorandum and judgment order.

I plan to present a stipulated motion for an order releasing the supersedeas bond Friday. Judge Hoffman did not award costs to any party, either at the conclusion of the trial in 1968, or in the judgment now entered. However, I hope to have the Foundation pay the costs awarded by the Court of Appeals and the Supreme Court shortly. If they continue to resist, I will go to the clerk for an order.

Very truly yours,

Richard S. Phillips

RSP:iag

- * Enclosure

cc: Mr. R. H. Rines

LAW OFFICES

HOFGREN, WEGNER, ALLEN, STELLMAN & McCORD

20 NORTH WACKER DRIVE

CHICAGO 60606

TELEPHONE
FINANCIAL 6-1630
AREA CODE 312

JOHN REX ALLEN
1945-1989

AXEL A. HOFGREN
ERNEST A. WEGNER
WILLIAM J. STELLMAN
JOHN B. McCORD
BRADFORD WILES
JAMES C. WOOD
STANLEY C. DALTON
RICHARD S. PHILLIPS
LLOYD W. MASON
TED E. KILLINGSWORTH
CHARLES L. ROWE
W. E. RECKTENWALD
DILLIS V. ALLEN
WM. A. VAN SANTEN
RONALD L. WANKE
LOUIS A. HECHT

September 29, 1971

Mr. Theodore W. Anderson, Jr.
Pendleton, Neuman, Williams & Anderson
77 West Washington Street
Chicago, Illinois 60602

Dear Ted:

* I enclose a copy of Judge Hoffman's memorandum and judgment order in the Blonder-Tongue case. There is apparently a typographic error noted on page 5 which we have called to the Judge's attention.

Very truly yours,

Richard S. Phillips

RSP:iag

* Enclosure

AXEL A. HOFGREN
ERNEST A. WEGNER
WILLIAM J. STELLMAN
JOHN B. McCORD
BRADFORD WILES
JAMES C. WOOD
STANLEY C. DALTON
RICHARD S. PHILLIPS
LLOYD W. MASON
TED E. KILLINGSWORTH
CHARLES L. ROWE
W. E. RECKTENWALD
DILLIS V. ALLEN
W. A. VAN SANTEN
RONALD L. WANKE
LOUIS A. HECHT

LAW OFFICES

HOFGREN, WEGNER, ALLEN, STELLMAN & McCORD
20 NORTH WACKER DRIVE
CHICAGO 60606

TELEPHONE
FINANCIAL 6-16
AREA CODE 312
—
JOHN REX ALLEN
1945-1969

September 29, 1971

Mr. Keith J. Kulie
135 South LaSalle Street, Rm. 1845
Chicago, Illinois 60603

Dear Keith:

* I enclose a copy of Judge Hoffman's memorandum and judgment order in the Blonder-Tongue case. There is apparently a typographic error noted on page 5 which we have called to the Judge's attention.

Very truly yours,

Richard S. Phillips

RSP:iag

* Enclosure

Dictated 9/23/71

Note for file Blonder Tongue - University of Illinois case

Needleman called Dick Phillips relative to the collection of costs awarded by the Supreme Court in the BT case. Checking out with Mr. Davis Chief ~~Deputy~~ Deputy Clerk of our court here. I was informed that the proper way to proceed was to obtain an execution for costs from the District Court in Chicago and deliver the execution to the Marshall for levy. The same procedure I would assume should be ~~x~~ followed with reference to the costs allowed by the Court of Appeals. I telephoned Dick Phillips at 3:10 P.M. that day and gave him this information and he advised me that in the event he did not receive payment of the costs ~~x~~ by next week, I would immediately follow the procedure as outlined above.

RNc/h

LAW OFFICES

HOFGREN, WEGNER, ALLEN, STELLMAN & McCORD

20 NORTH WACKER DRIVE

CHICAGO 60606

TELEPHONE
FINANCIAL 6-1630
AREA CODE 312

JOHN REX ALLEN
1945-1969

AXEL A. HOFGREN
ERNEST A. WEGNER
WILLIAM J. STELLMAN
JOHN B. McCORD
BRADFORD WILES
JAMES C. WOOD
STANLEY C. DALTON
RICHARD S. PHILLIPS
LLOYD W. MASON
TED E. KILLINGSWORTH
CHARLES L. ROWE
W. E. RECKTENWALD
DILLIS V. ALLEN
WM. A. VAN SANTEN
RONALD L. WANKE
LOUIS A. HECHT

September 13, 1971

file
RECEIVED
SEP 15 1971
RINES AND RINES
NO. TEN POST OFFICE SQUARE, BOSTON

Mr. Robert H. Rines
Rines and Rines
No. Ten Post Office Square
Boston, Massachusetts 02109

Dear Bob:

Judge Hoffman this morning, after taking two hours to dispose of an assortment of motions and criminal matters, told Bill Marshall and me that he had not yet had an opportunity to consider the motions we have pending before him. He put the case over for three weeks with the additional observation that he hoped to reach his decision and call us in before that time.

Very truly yours,

Dick

Richard S. Phillips

RSP:iag

cc: Mr. I. S. Blonder

LAW OFFICES

Hofgren, Wegner, Allen, Stellman & McCord

20 NORTH WACKER DRIVE

CHICAGO 60606

TELEPHONE
FINANCIAL 6-1630
AREA CODE 312

JOHN REX ALLEN
1945-1969

AXEL A. HOFGREN
ERNEST A. WEGNER
WILLIAM J. STELLMAN
JOHN B. McCORD
BRADFORD WILES
JAMES C. WOOD
STANLEY C. DALTON
RICHARD S. PHILLIPS
LLOYD W. MASON
TED E. KILLINGSWORTH
CHARLES L. ROWE
W. E. RECKTENWALD
DILLIS V. ALLEN
WM. A. VAN SANTEN
RONALD L. WANKE
LOUIS A. HECHT

September 13, 1971

Mr. John F. Pearne
McNenny, Farrington,
Pearne & Gordon
450 Tower East
Cleveland, Ohio 44122

RE: UIF v. BT v. JFD

Dear John:

* We will have a few copies of the petition left
and I enclose one.

Bill Marshall and I were before Judge Hoffman
this morning but he had not yet reached a decision on
the motions.

Very truly yours,

Richard S. Phillips

RSP:iag

* Enclosure

cc: Mr. R. H. Rines ✓

LAW OFFICES

Hofgren, Wegner, Allen, Stellman & McCord

20 NORTH WACKER DRIVE
CHICAGO 60606

TELEPHONE
FINANCIAL 6-1630
AREA CODE 312
JOHN REX ALLEN
1946-1969

AXEL A. HOFGREN
ERNEST A. WEGNER
WILLIAM J. STELLMAN
JOHN B. McCORD
BRADFORD WILES
JAMES C. WOOD
STANLEY C. DALTON
RICHARD S. PHILLIPS
LLOYD W. MASON
TED E. KILLINGSWORTH
CHARLES L. ROWE
W. E. RECKTENWALD
DILLIS V. ALLEN
WM. A. VAN SANTEN
RONALD L. WANKE
LOUIS A. RECHT

September 16, 1971

RECEIVED

SEP 20 1971

RINES AND RINES
NO. TEN POST OFFICE SQUARE, BOSTON

Mr. Basil P. Mann
Merriam, Marshall, Shapiro & Klose
Two First National Plaza
Chicago, Illinois 60670

RE: University of Illinois Foundation
v. Blonder-Tongue v. JFD

Dear Pete:

We had some correspondence in July regarding the payment of costs awarded to Blonder-Tongue from the Foundation by the Court of Appeals and the Supreme Court. Our client has asked that we request that the Foundation pay this sum now, rather than waiting until the final resolution of the case which may be some months in the future.

If payment is not made promptly, I have been authorized to file a motion for an order of court compelling payment.

Very truly yours,

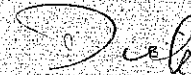

Richard S. Phillips

RSP:iag

cc: J. S. Blonder

LAW OFFICES

HOFGREN. WEGNER. ALLEN, STELLMAN & McCORD

20 NORTH WACKER DRIVE
CHICAGO 60606

TELEPHONE
FINANCIAL 61630
AREA CODE 312
JOHN REX ALLEN
1945-1969

AXEL A. HOFGREN
ERNEST A. WEGNER
WILLIAM J. STELLMAN
JOHN B. McCORD
BRADFORD WILES
JAMES C. WOOD
STANLEY C. DALTON
RICHARD S. PHILLIPS
LLOYD W. MASON
TED E. KILLINGSWORTH
CHARLES L. ROWE
W. E. RECKTENWALD
DILLIS V. ALLEN
WM. A. VAN SANTEN
RONALD L. WANKE
LOUIS A. HECHT

September 21, 1971

RECEIVED
SEP 23 1971
RINES AND RINES
NO. TEN POST OFFICE SQUARE, BOSTON

Mr. Basil P. Mann
Merriam, Marshall, Shapiro & Klose
Two First National Plaza
Chicago, Illinois 60670

RE: UIF v. BT v. JFD

Dear Pete:

I suggest you check the Cyclopedia of Federal Procedure, 3rd Edition, Section 38.57, which states that an award of costs cannot be set off against a judgment. Furthermore, Blonder-Tongue paid the Foundation's costs promptly following the trial although it was proceeding with the appeal.

Very truly yours,

Richard S. Phillips

RSP:iag

cc: Mr. R. H. Rines -- I made a short search but did not find
Mr. I. S. Blonder any cases clearly in point. Do
you know of any?

CHARLES J. MERRIAM
WILLIAM A. MARSHALL
JEROME B. KLOSE
NORMAN M. SHAPIRO
BASIL P. MANN
CLYDE V. ERWIN, JR.
ALVIN D. SHULMAN
EDWARD M. O'TOOLE
ALLEN H. GERSTEIN

LAW OFFICES

MERRIAM, MARSHALL, SHAPIRO & KLOSE

TWO FIRST NATIONAL PLAZA
CHICAGO, ILLINOIS 60670

TELEPHONE
312-346-5750
TELEX 25-3856

OWEN J. MURRAY
DONALD E. EGAN
NATE F. SCARPELLI
CARL KUSTIN
MICHAEL P. BUCKLO
CARL E. MOORE, JR.
ROBERT D. WEIST
MICHAEL F. BORUN

September 20, 1971

Mr. Richard S. Phillips
Hofgren, Wegner, Allen,
Stellman & McCord
20 North Wacker Drive
Chicago, Illinois 60606

Re: University of Illinois Foundation
v. Blonder-Tongue

Dear Dick:

Referring to your letter of September 16, 1971, we still believe that the issue of interim costs should be postponed to a final accounting. Nevertheless, since it is apparently your decision to press this point and since the issue may have to be resolved on the basis of the law, I would appreciate learning from you informally the basis on which you base your purported right for payment at this time. I have been unable to find any clear cut decision either way, but if you can establish a good basis for your position we may be able to avoid taking it to court on a motion.

Very truly yours,

Pete
Basil P. Mann

BPM/kd

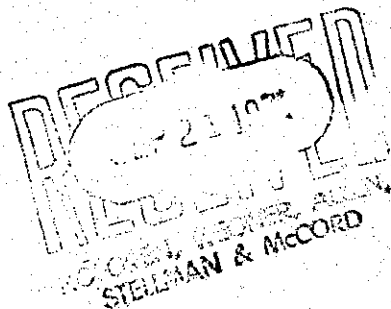

July 1, 1971

Richard S. Phillips, Esquire
Hofgren, Wegner, Allen, Stellman &
McCord
20 North Wacker Drive
Chicago, Illinois 60606

Dear Mr. Phillips:

We have your letter dated June 22, 1971 and the enclosure. As you know, Mr. Rines is out of the country but should be returning in about two weeks.

At any rate, we do not believe that any of the matters brought up in your letter require any action at this end at this time.

We enclose for your file a copy of a Certificate from the Seventh Circuit in connection with the same case on the matter of cost, as well as a copy of a letter dated June 15, 1971 relating to the same matter.

Would you be good enough to take whatever steps are necessary in connection with the enclosures.

Very truly yours,

RINES AND RINES

Lori Antonelli
Secretary

la
Enclosures

LAW OFFICES

HOFGREN, WEGNER, ALLEN, STELLMAN & McCORD

20 NORTH WACKER DRIVE

CHICAGO 60606

TELEPHONE
FINANCIAL 6-1630
AREA CODE 312

JOHN REX ALLEN
1945-1968

AXEL A. HOFGREN
ERNEST A. WEGNER
WILLIAM J. STELLMAN
JOHN B. McCORD
BRADFORD WILES
JAMES C. WOOD
STANLEY C. DALTON
RICHARD S. PHILLIPS
LLOYD W. MASON
TED E. KILLINGSWORTH
CHARLES L. ROWE
JAMES R. SWEENEY
W. E. RECKTENWALD
J. R. STAPLETON
WILLIAM R. McNAIR
DILLIS V. ALLEN
W. A. VAN SANTEN
JOHN R. HOFFMAN
RONALD L. WANKE
LOUIS A. HECHT

June 22, 1971

RECEIVED

JUN 24 1971

Mr. Robert H. Rines
Rines and Rines
No. Ten Post Office Square
Boston, Massachusetts 02109

RINES AND RINES
NO. TEN POST OFFICE SQUARE, BOSTON

Dear Bob:

*

I enclose a copy of a communication directed from the Supreme Court to the District Court, which was just received by the Clerk last Thursday. I am proceeding with the preparation of an amended complaint and presently plan to move the court for permission to file it next week. I would expect the court to grant that motion and to allow the Foundation 20 or 30 days in which to file an amended reply.

I have already talked with Pete Mann regarding the costs, one-half of which has been assessed against the Foundation. I believe he is planning to petition the Clerk of the Supreme Court to assess some portion of the costs against JFD. I am afraid this will delay the payment of the costs somewhat. However, I will do whatever I can to get the money as soon as possible. If the Foundation appears to be intentionally delaying, I will file a motion with the court for an order that the costs be paid.

Very truly yours,

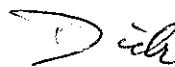

Richard S. Phillips

RSP:iag

*

Enclosure

cc: Mr. I. S. Blonder
Mr. B. H. Tongue

SUPREME COURT OF THE UNITED STATES
OFFICE OF THE CLERK
WASHINGTON, D. C. 20543

June 15, 1971

E. ROBERT SEAVER
CLERK OF THE COURT

Robert H. Rines, Esquire
Counselor at law
No. Ten Post Office Square
Boston, Mass. 02109

RECEIVED

JUN 17 1971

RINES AND RINES
NO. TEN POST OFFICE SQUARE, BOSTON

RE: Blonder-Tongue Laboratories, Inc.
v. University of Ill. Foundation
et al., No. 338, Oct. Term, 1970

Dear Mr. Rines:

A certified copy of the judgment of this Court in the above-entitled case has been mailed today to the Clerk of the United States District Court for the Northern District of Illinois.

The total costs in this Court for printing record and Clerk's costs is as follows:

Clerk's costs	\$	150.00
Printing of record		<u>8,372.90</u>
Total	\$	8,522.90

Your client is given recovery for one half of the total costs which amounts to \$4,261.45. This amount may be collected through the United States District Court for the Northern District of Illinois or direct from opposing counsel or parties.

Very truly yours,

E. ROBERT SEAVER, Clerk

By *Evelyn R. Limstrong*

(Mrs.) Evelyn R. Limstrong
Assistant

AIRMAIL

United States Court of Appeals

For the Seventh Circuit

219 South Dearborn Street

Chicago, Illinois 60604

Kenneth J. Carrick

Clerk

RECEIVED

AUG 6 1971

August 3, 1971

Mr. H. Stuart Cunningham, Clerk
United States District Court
Federal Building
Chicago, Illinois 60604

RINES AND RINES
NO. TEN POST OFFICE SQUARE, BOSTON

UNIVERSITY OF ILLINOIS FOUNDATION, Plaintiff & Counterclaim
vs. Defendant, Appellee
Re: BLONDER-TONGUE LABORATORIES, Inc., Defendant & Counterclaimant,
vs. Appellant,

JED ELECTRONICS CORPORATION, Counterclaim Defendant, Appellee.
U.S.C.A.-7 No. 17153
District Court No. 66C567

Dear Sir:

~~Herewith is the mandate of this Court in the above entitled appeal.~~ I am returning the original record of your District Court, which was transmitted to this office for use on appeal.

Please acknowledge receipt on the enclosed copy of this letter.

Sincerely yours,

KENNETH J. CARRICK, Clerk

William H. Pittman

By: William H. Pittman

Deputy Clerk

Date: _____

Received above ~~mandate~~ and record from the Clerk of the United States Court of Appeals for the Seventh Circuit.

Clerk

Copies mailed to:

Mr. Wm. A. Marshall, Two First National Plaza, Chicago, Illinois 60670
Mr. John Rex Allen, 20 North Wacker Drive, Chicago, Illinois
Mr. Robert S. Rines, 10 Post Office Square, Boston, Massachusetts 02109
Mr. Jerome M. Berliner, 10 East 40th Street, New York, New York
Mr. Myron C. Cass, 105 W. Adams Street, Chicago, Illinois

RECORD = 1 volume pleadings, 21 volumes transcript, 5 envelopes depositions...

Gentlemen:

If any physical and large documentary exhibits have been filed in the above entitled cause, they are to be withdrawn within ten days from the date of this notice. Exhibits not withdrawn during this period will be disposed of.

LAW OFFICES

HOFGREN, WEGNER, ALLEN, STELLMAN & McCORD

20 NORTH WACKER DRIVE

CHICAGO 60606

TELEPHONE
FINANCIAL 6-1630
AREA CODE 312

JOHN REX ALLEN
1945-1969

AXEL A. HOFGREN
ERNEST A. WEGNER
WILLIAM J. STELLMAN
JOHN B. McCORD
BRADFORD WILES
JAMES C. WOOD
STANLEY C. DALTON
RICHARD S. PHILLIPS
LOYD W. MASON
TED E. KILLINGSWORTH
CHARLES L. ROWE
JAMES R. SWEENEY
W. E. RECKTENWALD
J. R. STAPLETON
WILLIAM R. McNAIR
DILLIS V. ALLEN
WM. A. VAN SANTEN
JOHN R. HOFFMAN
RONALD L. WANKE
LOUIS A. BECHT

July 29, 1971

RECEIVED

JUL 30 1971

RINES AND RINES
NO. TEN POST OFFICE SQUARE, BOSTON

Mr. Isaac S. Blonder
Blonder-Tongue Laboratories Inc.
P/O Box 664
One Jake Brown Road
Old Bridge, New Jersey 08857

Dear Ike:

* I enclose a copy of a letter from Mann regarding our request for payment of the costs. I will keep after him on this.

Very truly yours,

Richard S. Phillips

RSP:iag

* Enclosure

cc: Mr. R. H. Rines (*)

CHARLES J. MERRIAM
WILLIAM A. MARSHALL
JEROME S. KLOSE
NORMAN M. SHAPIRO
BASIL P. MANN
CLYDE V. ERWIN, JR.
ALVIN D. SHULMAN
EDWARD M. O'TOOLE
ALLEN H. GERSTEIN

LAW OFFICES

MERRIAM, MARSHALL, SHAPIRO & KLOSE

TWO FIRST NATIONAL PLAZA
CHICAGO, ILLINOIS 60670

TELEPHONE
312-346-5750
TELEX 25-3856

OWEN J. MURRAY
DONALD E. EGAN
NATE F. SCARPELLI
CARL KUSTIN
MICHAEL P. BUCKLO
CARL E. MOORE, JR.
ROBERT D. WEIST
MICHAEL F. BORUN

July 22, 1971

Richard S. Phillips, Esq.
HOFGREN, WEGNER, ALLEN,
STELLMAN & McCORD
20 North Wacker Drive
Chicago, Illinois 60606

Re: University of Illinois Foundation
v. Bonder-Tongue v. JFD

Dear Dick:

Please refer to your letter of July 21, 1971 regarding costs in this case.

As I have stated to you in the past in response to your similar requests, we prefer to defer consideration of items such as interim awards of costs until the final resolution of the issues in the case, so that a final accounting can take care of all outstanding matters. This we feel is a more satisfactory procedure than handling these items individually on a piece-meal basis. In view of the relatively small amounts involved and the fact that this case will undoubtedly be finally decided in the near future, we do not feel that it would be an undue hardship on Blonder-Tongue to wait for a final accounting.

Incidentally, there is some question regarding the amount which the Supreme Court ordered the Foundation to pay. The order referred to both the Foundation and JFD, and in discussing the matter with the Clerk of The Supreme Court, I was told that the usual procedure in a case of this type would be for the parties, i.e., the Foundation and JFD, to divide the costs. Although I have not discussed the matter with JFD, I assume that this is the procedure which will be followed.

Sincerely yours,

Pete
Basil P. Mann

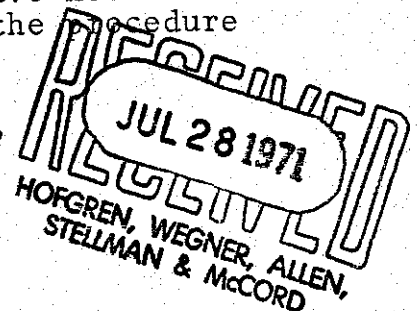

BPM/kd
cc: Mr. M. C. Cass

LAW OFFICES

HOFGREN, WEGNER, ALLEN, STELLMAN & McCORD

20 NORTH WACKER DRIVE

CHICAGO 60606

AXEL A. HOFGREN
ERNEST A. WEGNER
WILLIAM J. STELLMAN
JOHN B. McCORD
BRADFORD WILES
JAMES C. WOOD
STANLEY C. DALTON
RICHARD S. PHILLIPS
LLOYD W. MASON
TED E. KILLINGSWORTH
CHARLES L. ROWE
W. E. RECKTENWALD
DILLIS V. ALLEN
WM. A. VAN SANTEN
RONALD L. WANKE
LOUIS A. HECHT

TELEPHONE
FINANCIAL 6-1630
AREA CODE 312
—
JOHN REX ALLEN
1945-1969

July 30, 1971

RECEIVED

AUG 2 1971

RINES AND RINES
NO. TEN POST OFFICE SQUARE, BOSTON

Mr. Robert H. Rines
Rines and Rines
No. Ten Post Office Square
Boston, Massachusetts 02109

Dear Bob:

We had a hearing this morning before Judge Hoffman on our motions to file an additional memorandum and on our motion for judgment. Marshall appeared for the Foundation and argued that the question of claims 6, 7 and 8 was not newly raised in their reply but was mentioned in a footnote to the second proposed supplemental finding of fact which they had submitted. Judge Hoffman said there had to be an end to the filing of memoranda and that since a response to their reply is not permitted under Rule 13, he would deny the motion.

With regard to our motion for judgment, Marshall said all the facts and arguments are of record and that the Foundation, while opposing the motion, did not wish to make a written presentation. Judge Hoffman said he would read all the memoranda and, if he wished further argument, let the parties know.

I don't know his vacation plans, but regular court sessions do not reconvene until September 13.

Very truly yours,



Richard S. Phillips

RSP:iag

cc: Mr. I. S. Blonder
Mr. J. F. Pearne

LAW OFFICES

HOFGREN. WEGNER. ALLEN. STELLMAN & McCORD

20 NORTH WACKER DRIVE

CHICAGO 60606

TELEPHONE
FINANCIAL 6-1630
AREA CODE 312

JOHN REX ALLEN
1945-1969

AXEL A. HOFGREN
ERNEST A. WEGNER
WILLIAM J. STELLMAN
JOHN B. McCORD
BRADFORD WILES
JAMES C. WOOD
STANLEY C. DALTON
RICHARD S. PHILLIPS
LLOYD W. MASON
TED E. KILLINGSWORTH
CHARLES L. ROWE
W. E. RECKTENWALD
DILLIS V. ALLEN
WM. A. VAN SANTEN
RONALD L. WANKE
LOUIS A. HECHT

July 29, 1971

RECEIVED

AUG 2 1971

RINES AND RINES
NO. TEN POST OFFICE SQUARE, BOSTON

Mr. Robert H. Rines
Rines and Rines
No. Ten Post Office Square
Boston, Massachusetts 02109

RE: UIF v. BT v. JFD

Dear Bob:

* Attached are copies of the material being served and filed Thursday afternoon, July 29, for a hearing before Judge Hoffman Friday morning, July 30. This is the last day Judge Hoffman is emergency judge, and I feel it is essential that this all be submitted to him now rather than waiting for the fall session of court which starts September 13.

I don't think anything further should or need be done at the present time. However, if you have any suggestions, let me know.

Very truly yours,



Richard S. Phillips

RSP:iag

* Enclosures

LAW OFFICES

HOFGREN, WEGNER, ALLEN, STELLMAN & McCORD

20 NORTH WACKER DRIVE

CHICAGO 60606

TELEPHONE
FINANCIAL 6-1630
AREA CODE 312

JOHN REX ALLEN
1945-1969

AXEL A. HOFGREN
ERNEST A. WEGNER
WILLIAM J. STELLMAN
JOHN B. McCORD
BRADFORD WILES
JAMES C. WOOD
STANLEY C. DALTON
RICHARD S. PHILLIPS
LLOYD W. MASON
TED E. KILLINGSWORTH
CHARLES L. ROWE
W. E. RECKTENWALD
DILLIS V. ALLEN
W. A. VAN SANTEN
RONALD L. WANKE
LOUIS A. HECHT

July 29, 1971

Mr. John F. Pearne
McNenny, Farrington, Pearne & Gordon
920 Midland Building
Cleveland, Ohio 44115

RE: UIF v. BT v. JFD

Dear John:

I modified the memorandum sent you somewhat to incorporate some suggestions made by Jim Wood and to add a reference to the Monsanto decision which Walt Wyss saw and called me about this morning. I have not included a copy of the Winegard answer. If you don't have it in your papers and would like one, let me know. Jim Wood and I discussed using some of the briefs in the Winegard case and decided it was rather negative evidence and that it probably would not be helpful.

Very truly yours,

Richard S. Phillips

RSP:iag

Enclosure

cc: Mr. R. H. Rines ✓

LAW OFFICES

HOFGREN, WEGNER, ALLEN, STELLMAN & McCORD

20 NORTH WACKER DRIVE

CHICAGO 60606

TELEPHONE
FINANCIAL 6-1630
AREA CODE 312

JOHN REX ALLEN
1945-1969

AXEL A. HOFGREN
ERNEST A. WEGNER
WILLIAM J. STELLMAN
JOHN B. McCORD
BRADFORD WILES
JAMES C. WOOD
STANLEY C. DALTON
RICHARD S. PHILLIPS
LLOYD W. MASON
TED E. KILLINGSWORTH
CHARLES L. ROWE
W. E. RECKTENWALD
DILLIS V. ALLEN
W. A. VAN SANTEN
RONALD L. WANKE
LOUIS A. HECHT

July 29, 1971

Mr. Isaac S. Blonder
Blonder-Tongue Laboratories Inc.
P/O Box 664
One Jake Brown Road
Old Bridge, New Jersey 08857

Dear Ike:

Judge Hoffman ends his tour as emergency judge tomorrow and it is likely he will make a decision regarding the Foundation's motion for judgment before the court reconvenes in September. Accordingly, I decided we should not wait for Bob to come back from Europe. I have prepared a response to some additional arguments by the Foundation and a motion for judgment on your behalf, dismissing the complaint. Copies are enclosed.

Very truly yours,

Richard S. Phillips

RSP:iag

Enclosures

cc: Mr. R. H. Rines ✓

Court of Appeals, Fifth Circuit**MONSANTO COMPANY v. DAWSON CHEMICAL COMPANY et al.**

No. 30687

Decided June 8, 1971

PATENTS**Particular patents—Herbicide**

3,382,280, Huffman, 3, 4-Dichloropropionanilide, action remanded.

Appeal from District Court for Southern District of Texas, Singleton, J.; 165 USPQ 560.

Action by Monsanto Company against Dawson Chemical Company and Crystal Chemical Company for patent infringement. From judgment for plaintiff, defendants appeal. Reversed.

NED L. CONLEY, Houston, Tex., for appellants.

GARRETT R. TUCKER, JR., Houston, Tex., C. FREDERICK LEYDIG and JOHN E. ROSENQUIST, both of Chicago, Ill., and ARNOLD H. COLE, St. Louis, Mo., for appellee.

Before GOLDBERG, GODBOLD, and RONEY, Circuit Judges.

GOLDBERG, Circuit Judge.

This is a patent infringement suit between Monsanto Company, the patentee plaintiff, and defendant Dawson Chemical Company, a wholly owned subsidiary of defendant Crystal Chemical Company. The subject matter of the dispute is a chemical compound known as 3, 4-dichloropropionanilide. This compound, also known as propionil or 3, 4-DCPA is used as a selective, post-emergence herbicide. The plaintiff and defendant Dawson Chemical both market a herbicide containing 3, 4-DCPA, and defendants admit that if plaintiff's patent on 3, 4-DCPA is valid they have infringed that patent. Defendants claim, however, that plaintiff's patent is invalid, and that for this reason they have not infringed.

The district court held on April 14, 1970, that Monsanto's patent on 3, 4-DCPA was valid and that defendants were guilty of infringement. In so doing the court found (1) that 3, 4-DCPA was not anticipated by prior art within the meaning of 35 U.S.C.A. § 102(a) and (b); (2) that the compound was not obvious within the meaning of 35 U.S.C.A. § 103; (3) that Monsanto did not perpetrate a fraud upon the Patent Office by withholding certain information in its patent

application; and (4) that Monsanto was not guilty of laches in seeking a patent on 3, 4-DCPA.

In the meantime Monsanto had filed an identical suit involving 3, 4-DCPA in the Eastern District of Pennsylvania against Rohm & Haas Company. In this suit defendant Rohm & Haas stipulated that if Monsanto's patent was valid, it had infringed. On February 17, 1970, almost two months before the decision rendered by the district court in our case, the court in the Eastern District of Pennsylvania rendered its opinion that the Monsanto patent on 3, 4-DCPA was invalid. In so holding that court found (1) that the chemical compound 3, 4-DCPA was anticipated within the meaning of 35 U.S.C.A. § 102(a) and (b); (2) that the compound was obvious within the meaning of 35 U.S.C.A. § 103; (3) that Monsanto intentionally withheld material facts in order to mislead the Patent Office and that Monsanto had come into court with unclean hands; and (4) that Monsanto was guilty of laches in asserting any right it had to patent 3, 4-DCPA. *Monsanto Company v. Rohm & Haas Company*, E.D. Penn. 1970, 312 F.Supp. 778, 164 USPQ 556.

The district court below recognized that the Rohm & Haas case presented a prior judgment on an identical subject, saying, 165 USPQ 560, 569:

"Before this opinion is concluded, it should be added that the possible effect of the decision in *Monsanto Co. v. Rohm & Haas Co.*, No. 68-1269, 164 USPQ 556 (E.D. Pa. 1970), upon the result here reached has been carefully considered. Even though there is an identity of subject matter between that case and this one, the fact nevertheless remains that there is no identity between the parties defendant, not for that matter is there any privity between the parties defendant in each respective action. Moreover, the defendants here have placed greater emphasis on certain prior art items, namely, Bienert and Fontein, than did the defendants in *Monsanto Co. v. Rohm & Haas Co.*, supra, though it is not clear whether the court in that case had exactly the same evidence before it as was offered here. The result on the issues resolved in *Monsanto Co. v. Rohm & Haas Co.*, supra, does not therefore relieve this Court of its judicial travail of reaching its own independent decision on the merits of the case between these parties and on this record, even though this brings about diametrically opposed decisions on the validity of the same patent against the same attack. There is no res judicata or es-

toppel by judgment flowing from the earlier decision precluding plaintiff from its day in court against these defendants. *Bros, Inc. v. W. E. Grace Mfg. Co.*, 351 F.2d 208, 147 USPQ 1 (5th Cir. 1965); *Edward Valves, Inc. v. Cameron Iron Works, supra*; *Graham v. Cockshutt Farm Equipment*, 256 F.2d 358, 117 USPQ 439 (5th Cir. 1958); *Miles v. Matthews*, 171 F.2d 38, 80 USPQ 1 (5th Cir. 1948)."

At the time the court below concluded that it was not relieved by the Pennsylvania judgment of the "judicial travail" of reaching its own decision on the merits, it was completely correct. The Supreme Court had long ago in *Triplett v. Lowell*, 1936, 297 U.S. 638, 56 S.Ct. 645, 80 L.Ed. 949, 29 USPQ 1, decided that even though a patent has been held invalid in another suit, the patent owners are entitled to attempt to demonstrate the validity of that same patent against defendants who were not involved in the prior determination of invalidity. In *Triplett* the Court said:

"While the contention now made is apparently for the first time seriously argued here, this Court has several times held valid the claims of a patent which had been held invalid by a circuit court of appeals in an earlier suit brought by the same plaintiff against another defendant. Expanded Metal Co. v. Bradford, 214 U.S. 366, 53 L.Ed. 1034, 29 S.Ct. 652; *Diamond Rubber Co. v. Consolidated Rubber Tire Co.* 220 U.S. 428, 55 L.Ed. 527, 31 S.Ct. 444; *Abercrombie & F. Co. v. Baldwin*, 245 U.S. 198, 62 L.Ed. 240, 38 S.Ct. 104. Before the establishment of the circuit court of appeals, an adverse decision as to the validity of a patent in one circuit appears not to have foreclosed litigation of the same issue in another, see *Barbed Wire Patent (Washburn & M. Mfg. Co. v. Beat 'Em All Barbed Wire Co.)* 143 U.S. 275, 36 L.Ed. 154, 12 S.Ct. 443, 450; compare *United States v. American Bell Teleph. Co.* 128 U.S. 315, 372, 32 L.Ed. 450, 463, 9 S.Ct. 90. That it does not now is implicitly recognized by the practice established under § 240 (a) of the Judicial Code, U.S.C.A. Title 28, § 347, and Rule 38 (5) of this Court, that certiorari will not usually be granted in patent cases unless there is a conflict in the decisions of circuit courts of appeals. We conclude that neither the rules of the common law applicable to successive litigations concerning the same subject matter, nor the disclaimer statute, precludes relitigation of the validity of a patent claim previously held invalid in a suit against a different defendant."

297 U.S. at 643-44, 29 USPQ at 4.

Therefore, in April, 1970, when the district court considered the matter, it was obligated by *Triplett* to make its own independent conclusion concerning the validity of the Monsanto patent on 3, 4-DCPA.

However, the proverbial slip twixt the cup and the lip occurred. On May 3, 1971, many months after the court below engaged in its ordeal of decision, and, indeed, after oral argument to this court, the Supreme Court with unanimous wisdom reversed its earlier holding in *Triplett*. The Court ruled that a patent owner is bound by the judgment of patent invalidity in a prior suit against a different defendant unless the patent owner can show that for some reason the prior judgment should not be given this estoppel effect. *Blonder-Tongue Laboratories v. University of Illinois Foundation*, 1971, ___ U.S. ___, ___ S.Ct. ___, ___ L.Ed.2d ___, 169 USPQ 513.

In *Blonder-Tongue* the Court said, 169 USPQ at 527:

"It is clear that judicial decisions have tended to depart from the rigid requirements of mutuality. In accordance with this trend, there has been a corresponding development of the lower courts' ability and facility in dealing with questions of when it is appropriate and fair to impose an estoppel against a party who has already litigated an issue once and lost. As one commentator has stated:

'Under the tests of time and subsequent developments, the Bernhard decision [*Bernhard v. Bank of America Natl. Trust & Savings Ass'n.*, 1942, 19 Cal.2d 807, 122 P.2d 892] has proved its merit and the mettle of its author. The abrasive action of new factual configurations and of actual human controversies, disposed of in the common-law tradition by competent courts, far more than the commentaries of academicians, leaves the decisions revealed for what it is, as it was written: a shining landmark of progress in justice and law administration.' *Currie, supra*, 53 Cal. L. Rev., at 37.

"When these judicial developments are considered in the light of our consistent view—last presented in *Lear, Inc. v. Adkins* [1969, 395 U.S. 653, 89 S.Ct. 1902, 23 L.Ed.2d 610, 162 USPQ 1]—that the holder of a patent should not be insulated from the assertion of defenses and thus allowed to exact royalties for the use of an idea that is not in fact patentable or that is beyond the scope of the patent monopoly granted, it is apparent that the uncritical

acceptance of the principle of mutuality of estoppel expressed in *Triplett v. Lowell* is today out of place. Thus, we conclude that Triplett should be overruled to the extent it forecloses a plea of estoppel by one facing a charge of infringement of a patent that has once been declared invalid."

Recognizing that collateral estoppel is an affirmative defense which must be pleaded, the Court remanded the case to the district court, saying, 169 USPQ at 527-528:

"Res judicata and collateral estoppel are affirmative defenses that must be pleaded. Fed. Rule Civ. Proc. 8(c). The purpose of such pleading is to give the opposing party notice of the plea of estoppel and a chance to argue, if he can, why the imposition of an estoppel would be inappropriate. Because of *Triplett v. Lowell*, petitioner did not plead estoppel and respondent never had an opportunity to challenge the appropriateness of such a plea on the grounds set forth in Part III A of this opinion. Therefore, given the partial overruling of Triplett, we remand the case. Petitioner should be allowed to amend its pleadings in the District Court to assert a plea of estoppel. Respondent must then be permitted to amend its pleadings, and to supplement the record with any evidence showing why an estoppel should not be imposed in this case. If necessary, petitioner may also supplement the record. In taking this action, we intimate no views on the other issues presented in this case. The judgment of the Court of Appeals is vacated and the cause is remanded to the District Court for further proceedings consistent with this opinion."

In the instant case we have a situation identical to that encountered by the Supreme Court in *Blonder-Tongue*. At the time the district court made its decision there was a final judgment of another court declaring Monsanto's patent on 3, 4-DCPA invalid. But for the Triplett doctrine the defendant here could have pled the collateral estoppel effect of this prior judgment. Following the directions of the Supreme Court, we remand this case to the district court to allow the defendant to amend its pleading to assert a plea of estoppel. The plaintiff should then be permitted to show the reasons, if any, why estoppel should not be allowed.

In conclusion, we reiterate that the learned trial judge could not have anticipated that the Supreme Court would still the compulsions of Triplett. He was therefore obligated to confront the chemical elements, their homologs,

and the other accoutrements of this patent litigation.

For the foregoing reasons, the cause is remanded to the district court for further proceedings consistent with the Supreme Court's decision in *Blonder-Tongue Laboratories v. University of Illinois Foundation*, supra.

Reversed and remanded.

Court of Appeals, Seventh Circuit

GRANTHAM et al. v. McGRAW-EDISON
COMPANY et al.

No. 18394 Decided June 10, 1971

PATENTS

1. Prior adjudication — Infringement suits (§56.15)

Blonder-Tongue v. Illinois, 169 USPQ 513, was not intended to constitute a wholesale rejection of mutuality requirement as applied to estoppel defense; holding does not reach case where there has been no determination of validity of patent.

Appeal from District Court for Northern District of Illinois, Parsons, J.

Action by Paulette Grantham, Fred Grantham, and Charles R. Grantham against McGraw-Edison Company, Essick Investment Co., and "Automatic" Sprinkler Corporation of America for patent infringement. From order dismissing complaint, plaintiffs appealed. Reversed at 170 USPQ 69. On petition for rehearing. Petition denied.

ALBERT LANGELUTTIG and PAUL H. GALLAGHER, both of Chicago, Ill., and ROBERT A. FELSMAN, Fort Worth, Tex., for appellants.

JAMES VAN SANTEN, Chicago, Ill., for appellees.

Before SWYGERT, Chief Judge, FAIRCHILD, Circuit Judge, and GORDON, District Judge.*

PER CURIAM.

In our analysis of collateral estoppel at part II of our opinion, 170 USPQ 69, we relied on *Triplett v. Lowell*, 297 U.S. 638, 29 USPQ 1 (1936), and related cases for the

* Judge Myron L. Gordon of the United States District Court for the Eastern District of Wisconsin is sitting by designation.

IN THE UNITED STATES DISTRICT COURT
FOR THE SOUTHERN DISTRICT OF IOWA
DAVENPORT DIVISION

FILED

APR 15 1966

F. E. VAN ALSTINE
CLERK, U. S. DISTRICT COURT
SOUTHERN DISTRICT OF IOWA

THE UNIVERSITY OF ILLINOIS FOUNDATION,

Plaintiff,

-vs-

WINEGARD COMPANY,

Defendant.

) Civil Action

) No. 2-405 E

) now Docketed

) and Identified

) as No. 3-695-D

A N S W E R

NOW comes WINEGARD COMPANY, the above named defendant, by its attorneys, and answers the complaint as follows:

1. Defendant, Winegard Company, is without knowledge or information sufficient to form a belief as to the truth of any averment of paragraph one of the complaint and leaves Plaintiff to its proofs thereon.

2. Winegard Company admits the allegations of paragraph two.

3. Winegard Company admits that this action purports to be a suit for patent infringement.

4. In response to paragraph four of the complaint, Winegard Company admits that Patent No. 3,210,767

issued on October 5, 1965 to one Dwight E. Isbell. Defendant is without knowledge as to each remaining allegation of paragraph four of the complaint and leaves the plaintiff to its proofs thereon.

5. Defendant denies each and every allegation of paragraph five of the complaint.

6. In further response to the complaint herein, Winegard Company states that the aforesaid Patent No. 3,210,767 is null and void and of no effect because the purported inventor, Dwight E. Isbell, was not entitled to a patent because, inter alia, he did not satisfy the conditions and requirements for patentability set forth in Title 35, Sections 102 and 103 of the United States Code.

7. Further in response to the complaint herein, Winegard Company alleges that the aforesaid Patent No. 3,210,767 is null and void and unenforceable because of failure to comply with Title 35, Section 112, United States Code, requiring that the specification of an application for patent set forth the best mode contemplated by the inventor of carrying out his invention.

WHEREFORE, Winegard Company prays that:

A. The relief sought by the within complaint be denied and the complaint be dismissed.

B. This Honorable Court enter its decree adjudging Patent No. 3,210,767 to be null and

void and of no force and effect, not binding
by the manufacture, use and sale of any antenna
or other product of Winegard Company, and not
enforceable.

C. Other and further relief be awarded
Winegard Company as is meet and just.

Respectively Submitted,

WINEGARD COMPANY

By

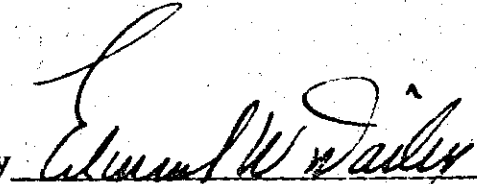

Edward W. Dailey
Dailey, Dailey, Ruther & Bauer
National Bank Building
P. O. Box 517
Burlington, Iowa 52601

Dated:

April 13, 1966

Of Counsel:

Keith J. Kulie
Donald B. Southard
Burmeister & Kulie
135 So. LaSalle St.
Chicago, Illinois 60603

CERTIFICATE

I, Edward W. Dailey, one of the attorneys for Winegard Company,
Defendant in the above and foregoing cause of action, hereby
certify that I mailed a copy of the foregoing Answer to David
J. Sohr, Attorney at Law of the firm of Cook, Blair, Balluff
and Nagle, attorneys for Plaintiff, 409 Putnam Building,
Davenport, Iowa, 52801, Area Code 319 - 323-8054, by prepaid
United States mail on the 14th day of April, 1966.

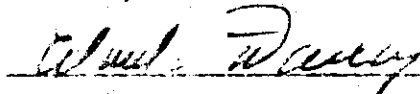

United States of America

SOUTHERN DISTRICT OF IOWA
Davenport Division

} ss:

I, R. E. Longstaff-----, Clerk of the United States District Court for the Southern District of Iowa, do hereby certify that the annexed and foregoing is a true and full copy of the original Answer of the Winegard Company, filed April 15, 1966 in Civil Action No. 3-695-D, THE UNIVERSITY OF ILLINOIS FOUNDATION, Plaintiff, vs. WINEGARD COMPANY, Defendant, such case originally filed March 8, 1966.

now remaining among the records of the said Court in my office.

IN TESTIMONY WHEREOF, I have hereunto subscribed my name and affixed the seal of the aforesaid Court at this 9th day of July, A. D. 1971.

R. E. LONGSTAFF

Clerk.

By Deputy Clerk
Deputy Clerk.



BLONDER·TONGUE LABORATORIES INC.

9 ALLING STREET, NEWARK, NEW JERSEY 07102 • (201) 622-8151

Jeli
Blonder Tongue

March 3, 1970

Robert H. Rines, Esquire
Rines and Rines
10 Post Office Square
Boston, Mass. 02109

Dear Bob:

Beauty is in the eye of the beholder, and nothing is more beautiful than your Petition for Clarification, etc.

The conciseness, clarity and brevity of your brief is a real model for the legal profession. Indeed, the whole case from beginning to end, could be the subject of a seminar at one of our better law schools. Obviously, no longer Harvard.

Since you wrote this thing for the benefit of the Supreme Court, when do we get there?

Sincerely,

Is

Isaac S. Blonder
Chairman of the Board

ISB:jg

cc: Richard S. Phillips, Esq.

RECEIVED

MAR 9 1970

LAW OFFICES

HOFGREN, WEGNER, ALLEN, STELLMAN & McCORD

20 NORTH WACKER DRIVE

CHICAGO 60606

AXEL A. HOFGREN
ERNEST A. WEGNER
WILLIAM J. STELLMAN
JOHN B. McCORD
BRADFORD WILES
JAMES C. WOOD
STANLEY C. DALTON
RICHARD S. PHILLIPS
LLOYD W. MASON
TED E. KILLINGSWORTH
CHARLES L. ROWE
W. E. RECKTENWALD
DILLIS V. ALLEN
W. A. VAN SANTEN
RONALD L. WANKE
LOUIS A. HECHT

TELEPHONE
FINANCIAL 6-1630
AREA CODE 312

JOHN REX ALLEN
1945-1969

July 28, 1971

file
New folder
Wm Del v BT
RECEIVED

JUL 30 1971

RINES AND RINES
NO. TEN POST OFFICE SQUARE, BOSTON

Mr. Robert H. Rines
Rines and Rines
No. Ten Post Office Square
Boston, Massachusetts 02109

Dear Bob:

* I enclose the Foundation's reply which was served on us by mail this morning. They raised for the first time the question of identity of issue as a bar to the estoppel.

* Our rules don't provide for an answering memorandum, so I have prepared a motion for special leave to file such a memorandum. It and the memorandum are enclosed. I plan on serving them Thursday for a Friday hearing on the motion. Please call me if you have any suggestions.

Very truly yours,

Rich

Richard S. Phillips

RSP:iag

* Enclosures

LAW OFFICES

HOFGREN, WEGNER, ALLEN, STELLMAN & MCCORD

20 NORTH WACKER DRIVE

CHICAGO 60606

TELEPHONE
FINANCIAL 6-1630
AREA CODE 312

JOHN REX ALLEN
1945-1969

AXEL A. HOFGREN
ERNEST A. WEGNER
WILLIAM J. STELLMAN
JOHN B. MCCORD
BRADFORD WILES
JAMES C. WOOD
STANLEY C. DALTON
RICHARD S. PHILLIPS
LLOYD W. MASON
TED E. KILLINGSWORTH
CHARLES L. ROWE
JAMES R. SWEENEY
W. E. RECKTENWALD
J. R. STAPLETON
WILLIAM R. MCNAIR
DILLIS V. ALLEN
WM. A. VAN SANTEN
JOHN R. HOFFMAN
RONALD L. WANKE
LOUIS A. HECHT

July 28, 1971

Mr. John F. Pearne
McNenny, Farrington, Pearne & Gordon
930 Midland Building
Cleveland, Ohio 44115

RE: UIF v. BT v. JFD

Dear John:

* I enclose the Foundation's reply to our memorandum and a copy of an answering memorandum I have drafted. Under our rules, we are not entitled to have this filed as a matter of right, but I am hopeful that the court will take it since it treats only the new argument of identity of issue raised by the Foundation. I plan to file this Thursday and present the motion Friday morning, which is the last day Judge Hoffman sits as emergency judge. Please call me with your comments and suggestions. If you don't receive this until Friday morning, call me any time after 9:15 your time at 346-1692. I generally leave the office about 9:30 our time to go to court for a ten o'clock call.

Very truly yours,

Richard S. Phillips

RSP:iag

* Enclosures

cc: Mr. R. H. Rines ✓

IN THE UNITED STATES DISTRICT COURT
FOR THE NORTHERN DISTRICT OF ILLINOIS
EASTERN DIVISION

THE UNIVERSITY OF ILLINOIS FOUNDATION,)
)
) Plaintiff and)
) Counterclaim Defendant,)
)
) - v -)
)
) BLONDER-TONGUE LABORATORIES, INC.,)
) CIVIL ACTION)
) Defendant and)
) Counterclaimant,) NO. 66 C 567)
)
) - v -)
)
) JFD ELECTRONICS CORPORATION,)
)
) Counterclaim Defendant.)

MOTION FOR LEAVE TO FILE A MEMORANDUM
ANSWERING PLAINTIFF'S REPLY TO
DEFENDANT'S MEMORANDUM IN OPPOSITION TO
ITS (PLAINTIFF'S) MOTION FOR
JUDGMENT AFTER REMAND

Now comes defendant and moves for leave to file the attached memorandum. Plaintiff in its Reply first raised the argument that estoppel is not proper, alleging that the issue in this Court is different from that in the prior Winegard decision. It is respectfully requested that this Court exercise its discretion and permit the filing of a memorandum answering this new argument under General Rule 13 and Civil Rule 19, Rules of the District Court for the Northern District of Illinois.

MEMORANDUM IN ANSWER TO
PLAINTIFF'S REPLY TO DEFENDANT'S MEMORANDUM
IN OPPOSITION TO ITS (PLAINTIFF'S) MOTION
FOR JUDGMENT AFTER REMAND

Plaintiff in its reply argues that the issue of validity of Isbell patent 3,210,767 decided against it in the Winegard suit was not identical with the issue of validity of the Isbell patent here, suggesting that the Winegard decision did not treat claims 6, 7 and 8.

A consideration of the facts illustrates the fallacy of this argument.

In the Winegard suit, the Foundation sought a finding that the Isbell patent had been infringed by Winegard, 271 F.Supp. at 413. Winegard answered alleging affirmatively that the Isbell patent was null and void and of no effect, see paragraphs 6 and 7 of the certified copy of Winegard's Answer, attached hereto.

Judge Stephenson found, not that certain claims were invalid, but that:

". . . the disclosure of Isbell's Patent No. 3,210,767 is lacking in the prerequisite nonobviousness and is, therefore, invalid." 271 F.Supp. at 419.

The breadth of this invalidity finding is clearly within the issues framed by the Answer and is not limited by the Court's earlier observation

"All of the claims except numbers 6, 7 and 8 are claimed to be infringed . . ." 271 F.Supp. at 415.

In fact, in Appendix A to the decision where the claims of Isbell are set forth, claims 6, 7 and 8 are included. 271 F.Supp. at 423.

The Court of Appeals for the Eighth Circuit affirmed, saying:

"We have examined the record and find that all claims must be denied, lacking nonobviousness as a matter of law for essentially the same reasons set forth by the court below." 402 F.2d at 126.

The withdrawal of an infringement charge does not deprive a court of jurisdiction to try validity. A similar situation was considered in International Minerals & Chemicals Corporation v. Golding-Keene Company, 164 F.Supp. 101 (DC WD NY 1958). Here, defendant had charged plaintiff with infringement whereupon plaintiff brought suit for declaratory judgment of patent invalidity. Defendant moved to dismiss on the ground that it had repudiated and withdrawn the infringement charge.

The court held:

"There is substantial authority for the proposition that once the validity of a patent has been put in issue along with the question of infringement, it is the better practice to determine the validity of the patent even though the charge of infringement is subsequently withdrawn. [Citing cases.] To the same effect, see E. J. Brooks Co. v. Stoffel Seals Corp., D.C.S.D.N.Y., 160 F.Supp. 581, at page 593, in which Judge Dawson observed, in

language singularly appropriate in the instant case, 'Defendant cannot create a situation of actual controversy which gives the Court jurisdiction under the Declaratory Judgment Act and then, after the commencement of suit, come into Court and seek to avoid the jurisdiction of the Court by belated concessions that there was no infringement.'" 164 F.Supp. 101 at 102.

See also Nelmor Corporation v. Jervis Corporation, 229 F.Supp. 864 (DC ED Mich. 1964), where the entire patent was held invalid despite the fact that most of the proofs at trial were concerned with only two claims, the Court said:

"It is thus clear from the pleadings that the validity of the entire patent was put in issue. This court could not rule only upon the validity of claims 2 and 20, but under the law was obliged to rule upon all the claims of the patent. [Citing cases.]" 229 F.Supp. at 871.

The question presented here is comparable to that faced by a court where it first determines that there is no infringement. It is common in such case to make a determination regarding validity. The reason for this is aptly stated in the B & S Screw Products Co. v. Cleveland Stamping Co., 233 F.Supp. 845 (DC ND Ohio 1964):

"We proceed to the question of validity, even though we have absolved the defendants of any culpable infringement, for two reasons. We are mindful, first, of the public interest; it is important to the public generally that an invalid patent 'should not remain in the art as

a scarecrow.' Addressograph-Multigraph Corp. v. Cooper, 156 F.2d 483 (2nd Cir. 1946). This pursuit of the public interest authorizes consideration of the patent even though we have already determined that the patent has not been infringed by the accused blocks of defendants." 233 F.Supp. at 850.

Plaintiff's motion for judgment should be denied.

Richard S. Phillips
Attorney for Defendant
20 North Wacker Drive
Chicago, Illinois 60606

July _____, 1971.

OF COUNSEL:

ROBERT H. RINES
DAVID RINES
RINES and RINES
No. Ten Post Office Square
Boston, Massachusetts 02109

HOFGREN, WEGNER, ALLEN, STELLMAN & McCORD
20 North Wacker Drive
Chicago, Illinois 60606

ACKNOWLEDGMENT OF SERVICE

I hereby acknowledge receipt of one copy of the foregoing Motion for Leave to File a Memorandum Answering Plaintiff's Reply to Defendant's Memorandum in Opposition to Its (Plaintiff's) Motion for Judgment After Remand this _____ day of July, 1971.

Attorney for Plaintiff

ACKNOWLEDGMENT OF SERVICE

I hereby acknowledge receipt of one copy of the foregoing Motion for Leave to File a Memorandum Answering Plaintiff's Reply to Defendant's Memorandum in Opposition to Its (Plaintiff's) Motion for Judgment After Remand this _____ day of July, 1971.

Attorney for
Counterclaim Defendant

Return to W88

Device Photolithography:

The Primary Pattern Generator Part I—Optical Design

By M. J. COWAN, D. R. HERRIOTT, A. M. JOHNSON and
A. ZACHARIAS

(Manuscript received July 10, 1970)

I. INTRODUCTION

The basic design concept of the primary pattern generator (PPG) is the production of a linearly scanning, small, constant-size light spot. The scanning system consists of a regular polygonal-prism mirror which rotates about its axis of highest symmetry. The mirror faces are used sequentially to reflect a collimated light beam into a lens (for example, the scanning lens of Fig. 1). The collimated light is focused to a spot which scans a line in the focal plane of the lens as the polygonal mirror rotates. Located in the focal plane of the lens is a flat, glass photographic plate. The glass plate is moved by the desired scan line separation during the time required to bring the succeeding mirror facet into proper position.

The collimated beam incident onto the rotating mirror is formed by the scanning lens from a diverging beam obtained from a laser. The location of the reflecting mirror facet must be close to the aperture plane of the scanning lens in order to insure that the mode is not truncated by the physical lens apertures after the light is reflected from the mirror facet. Translation of the reflecting facet will not affect the position of the focused spot; the spot position is uniquely determined by the directions of the incident collimated beam and of the reflecting mirror facet relative to the optic axis of the lens. A barrel distortion is designed into the scanning lens such that the linear velocity of the focused spot is proportional to the angular velocity of the rotating mirror.

The machine just described is basically analog along its fast-scan axis, although it is digital along the slow (substrate translation) axis. Since the required reproducibility is greater than the required accuracy,

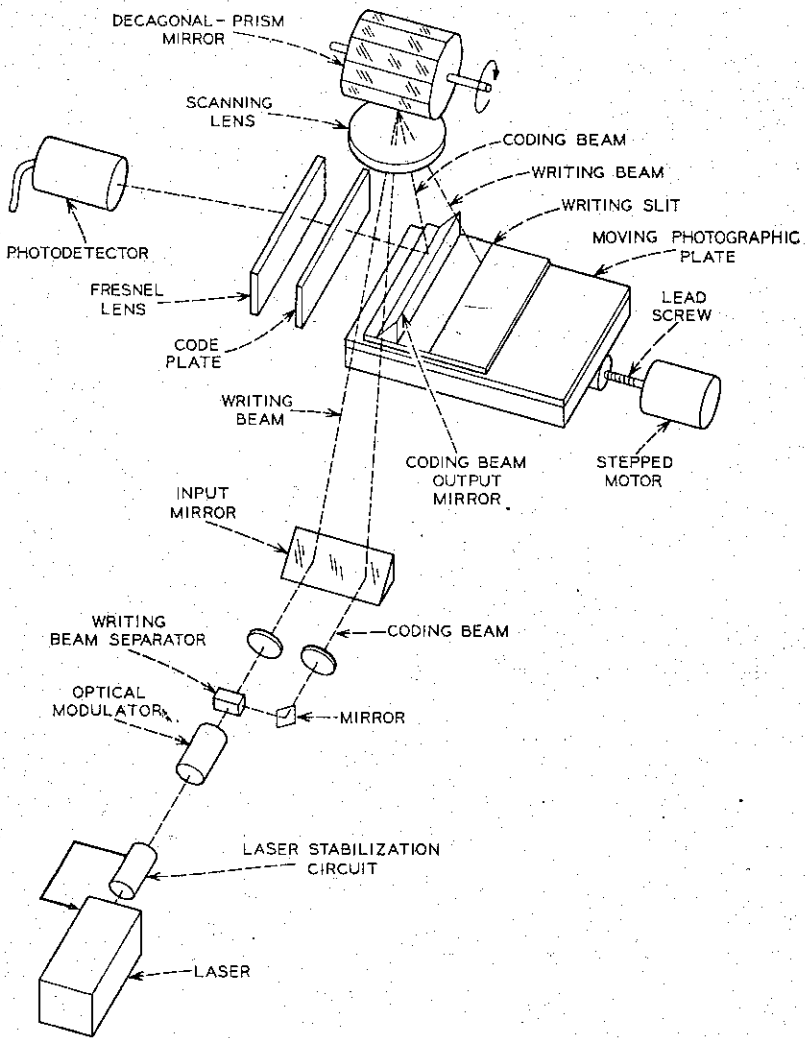

Fig. 1—Schematic of primary pattern generator.

a digitally operating machine is more desirable than an analog machine. The fast-axis can be made digital by using a separate beam to scan over a grating type of code plate. The location of this beam on the code plate tracks the position of the writing beam and generates timing pulses for a control computer. The resolution of the code plate must be as good as the reproducibility required; that is, the

code plate system must be capable of resolving 26,000 positions per scan length.

The pattern size is principally established by the capabilities of the scanning lens. The minimum spot diameter is determined by the approximate diffraction limitation of equation (1),¹ obtained when a lens aperture is uniformly illuminated.

$$I(r) = \left(\frac{2J_1(x)}{x} \right)^2 I_0 \quad x = \frac{\pi r}{\lambda f_n} \quad (1)$$

Here, f_n is the f -number of the lens forming the image $I(r)$; r is the radial distance from the image center; I_0 is a constant proportional to the intensity illuminating the aperture; and λ is the wavelength. Using this relation, we approximated the half-power diameter of a spot formed by such an illuminated lens to be

$$D \approx 0.58f_n \quad D \text{ in } \mu\text{m}, \lambda = 520 \text{ nm}. \quad (2)$$

We now consider that the polygonal mirror will have some wobble to its motion, and further, that all faces of the mirror will not be exactly parallel to the rotation axis. Consequently, to reduce the effect of these mirror defects on the pattern, the scanning lens should operate with as large a field angle as possible. This wide-angle requirement limits the f -number for which diffraction limited performance can be obtained in a lens. For a 48° field angle, calculations made by Tropel, Inc.,* showed that a minimum f -number of 13 could be used for good performance of the coding beam over the field. Using equation (2), a spot size of 7.5 μm half-power width is thus obtained; this will be approximately the size of the address unit. Since 26,000 address units are required for a full scan line, an address size of 7.0 μm will allow the full pattern of 26,000 by 32,000 address units to fit on a standard 8" \times 10" photographic plate.

To produce a complete pattern in less than 10 minutes, each of the 32,000 scan lines must be traversed in less than 20 ms. Since the writing-beam diameter will be less than twice the address spacing, the beam must sweep its own diameter in less than 800 ns. To produce sufficient exposure on high-resolution emulsion² requires a beam brightness obtainable only from a laser. However, the writing-beam power required is only 20 μW . Orthochromatic emulsion is desirable since it will allow a safelight environment. Thus an argon laser,³ operating at 5145 Å wavelength was chosen as the light source.

* Located at 52 West Avenue, Fairport, New York.

It operates in the lowest transverse mode,⁴ thus the radial intensity distribution anywhere in the beam path is gaussian. The output of the laser is stabilized by feedback through the laser power supply to a variation of less than 1 percent, thus insuring uniform exposure of the photographic plate.

II. THE PHOTOGRAPHIC EMULSION AND THE EXPOSURE PROCESS

The sweep of the writing beam across the photographic plate results in a variation of the exposure of the emulsion in a direction normal to the scanning direction. If we use the scanning velocity as v_0 and the intensity distribution of the scanning spot as

$$I(r) = \frac{2P}{\pi w^2} e^{-2r^2/w^2} \quad (3)$$

where P is the total power in the writing beam and w is the waist radius,⁵ then taking the scan to be x -directed along the line $y = y_0$, the variation of exposure in the y -direction is obtained by integration, as

$$\begin{aligned} E(y) &= \frac{2P}{\pi w^2} e^{-2(y-y_0)^2/w^2} \int_{-\infty}^{\infty} e^{-2(v_0 t)^2/w^2} dt, \\ &= \frac{P}{wv_0} \sqrt{\frac{2}{\pi}} e^{-2(y-y_0)^2/w^2}. \end{aligned} \quad (4)$$

The next line will scan with y_0 changed by one address spacing and the exposure produced by this scan will be added to the exposure of the first scan. The total exposure produced by N scans is thus obtained by summing N displaced gaussians given by equation (4).

A similar analysis is used to obtain the exposure resulting from modulation of the writing spot. In this case, the beam is turned off at $x = 0$ for each scan. As a first approximation, we assumed the intensity of the writing spot to decrease with a relaxation time of $\tau = d/v_0$ where d can be interpreted as a rise distance in analogy to a rise time. The exposure caused by a single trace having the beam turned off at $x = 0$ becomes

$$\begin{aligned} E(x, y) &= \frac{2P}{\pi w^2} e^{-2(y-y_0)^2/w^2} \left[\int_{-\infty}^0 e^{-2(x-v_0 t)^2/w^2} dt \right. \\ &\quad \left. + \int_0^{\infty} e^{-v_0 t/d} e^{-2(x-v_0 t)^2/w^2} dt \right] \end{aligned} \quad (5)$$

which is evaluated in terms of the error function and its complement.⁶

$$E(x, y) = \frac{P_0}{wv_0 \sqrt{2\pi}} e^{-2(y-y_0)^2/w^2} \cdot \left[\operatorname{erfc} \left(\frac{x\sqrt{2}}{w} \right) + e^{-x^2/d^2} e^{w^2/8d^2} \left(\operatorname{erf} \left(\frac{x\sqrt{2}}{w} - \frac{w\sqrt{2}}{4d} \right) + 1 \right) \right]. \quad (6)$$

Application of this exposure to a high-contrast emulsion will result in the production of a density gradient at the boundaries of the exposed regions. The greatest magnitude of the gradient will occur very close to the contour of 0.5 optical transmission through the developed image. The task of determining the actual image formed by the exposure function of equation (6) is thus reduced to tracing the contour of the exposure necessary to produce 0.5 transmission and to evaluate the exposure gradient normal to this contour. A computer program was written to evaluate equation (6) over a matrix of points. Table I shows some of the results of these calculations. An exposure of 1.00 is used to produce the 0.5 transmission value.

For simplest operation, five scan lines or a five-address modulation should produce an image five address units in dimension. To obtain a best compromise between freedom from mirror facet wobble and maximum edge gradient, we chose to operate with a half-power writing beam diameter between 1.3 and 1.7 address units (9 to 12 μm). Equation (4) can now be used to calculate the beam power required to obtain proper exposure on various emulsions. For a spot velocity of approximately 16 m/s, 20 μw of beam power will produce a maximum exposure of about 120 ergs/cm². High resolution plate² requires over 1000 ergs/cm² for proper exposure. Eastman Kodak Company had an emulsion which reached proper exposure between 20 and 100 ergs/cm², although it was not a standard product. This emulsion, called Minicard,

TABLE I—VARIATION OF EXPOSURE PARAMETERS

Half-Power Spot Diameter	2.7	2.0	1.7	1.3	2.0	1.7	1.3
Peak Exposure of a Single Scan	1.1	1.8	2.5	4.7	0.9	1.1	1.4
Width for 5-Scan Lines	6.0	6.0	6.0	6.0	5.0	5.0	5.0
Gradient ($\partial E/\partial y$)	1.0	1.5	2.0	3.1	1.0	1.2	1.7
Peak-Exposure for Large Number of Scan Lines	2.9	3.7	4.5	6.7	2.0	2.0	2.0
Length for 5-Address Modulation	6.1	6.2	6.3	6.5	5.0	5.0	5.0
Gradient ($\partial E/\partial x$)	0.9	1.3	1.6	2.1	0.8	0.9	1.0

was available on special order; Eastman Kodak now produces 8" × 10" glass plates coated with Minicard emulsion.

The glass photographic plates must have a very flat emulsion surface. Fig. 2 is an illustration of the effect of plate camber. The emulsion surface will be held near the extremes of the scan line. However, plate camber will cause registration errors between plates because of the angular scan of the writing beam. The maximum angle made by the writing beam and the normal to the photographic plate is 15°. To produce less than a one-address-length error between X_1 and X_2 of Fig. 2, the plate camber must be less than $\pm 28 \mu\text{m}$. This specification is safely met by Kodak microflat plates, but is very far from being met by the specifications of lower grades of glass plates.

III. THE ROTATING MIRROR AND SCANNING LENS

The dimensions of the rotating polygonal mirror are determined by the scanning-lens aperture. Since the f -number, field size and field angle of the scanning lens have been determined by equations (1) and (2), the aperture size is also determined. The facet size of the polygonal mirror can be found by geometry, as well as the overall size of the polygon. Referring to Fig. 3, the radius of the polygon must be large enough to keep the vertices out of the lens aperture during the rotation producing the scan of a line.

Since a gaussian illumination of the aperture is being used, the full aperture diameter must be larger than that computed from equation (2) for a uniformly illuminated lens. A best estimate of satisfactory performance with gaussian illumination was $f/10$ and the polygonal mirror was designed not to truncate this aperture during the scan. The value of R for this condition is 9.7 cm. The location of

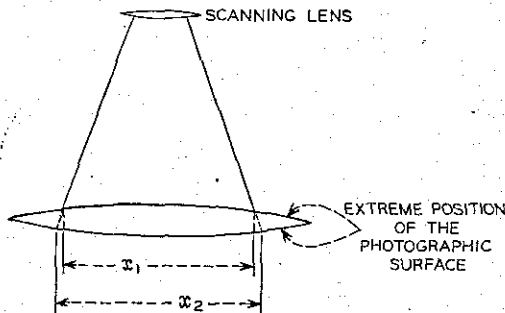

Fig. 2—The effect of photographic plate camber.

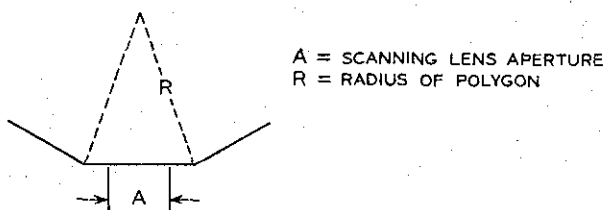

Fig. 3—Polygonal mirror-lens aperture geometry.

the aperture plane of the scanning lens must lie at the approximate location of the mirror facet. To obtain a uniform scanning velocity from constant angular velocity of the polygonal mirror, a $\theta/\tan \theta$ distortion was part of the scanning-lens design; θ is the angle between incident collimated light and the lens axis.

The number of facets on the polygonal mirror determines the ratio between the time available for writing and the unavailable time. Since the field angle of the written line is 45.4° , 22.7° of mirror rotation is spent writing a line. For the decagonal mirror used, 36° of mirror rotation is required to go from the start of one scan to the start of the next scan. Hence, 13.3° of rotation are unavailable. In order to write a complete pattern in 10 minutes, each scan line must be traversed in 18.8 ms; 11.8 ms writing and 7.0 ms waiting for the next facet to come into position. It is during this wait that the photographic plate is advanced one address spacing ($7 \mu\text{m}$).

IV. THE OPTICAL MODULATOR

The writing beam modulator used is an acousto-optic deflector.⁷ The modulator operates by the interaction of the laser beam with a 50-MHz ultrasonic wave in a piece of fused silica. This device deflects approximately 2 percent of the power of the incident laser beam at an angle of 4 mrad to the incident beam when the modulator is energized. Since the modulator is located in a near field region of the laser beam, the two beams emerge from the modulator each nearly collimated but having angular separation. These beams are then passed through a 10-cm focal length lens which transforms the angular divergence into a displacement sufficient for physical separation. The separation is accomplished by a knife edged mirror which has better than a 40-dB discrimination between the beams.

The 2 percent power in the deflected beam provides more than 17-dB on-off ratio and is limited by back reflections and scattering.

However, this is sufficient for the writing-beam modulation. The undeflected beam is used as the coding beam. The modulator has a rise time of less than 200 ns, including the transistor drivers. The transducer is X-cut crystal quartz.

V. MODE-MATCHING OPTICS

A series of lenses are required to transform the output mode of the laser to modes required for the modulator and then to the modes required by the scanning lens. The output of the laser is limited to a TEM₀₀ mode by use of an aperture within the laser cavity. The calculation of the positions and focal lengths of the required transforming lenses was done using the method described by H. Kogelnik.⁸

The first transformation is between the laser output and the optical modulator. The modulator requires a 300- μm waist radius in the fused silica. In turn, this mode is transformed to a 55- μm waist located at the knife-edged separation mirror. The writing beam is transformed to approximately a 9- μm waist radius at the object focal plane of the scanning lens and the proper writing spot is produced. The code beam is transformed by a pair of lenses. The first produces a mode having a waist radius of 800 μm , an essentially collimated beam for the 50-cm distance to the code plate. The second lens is a cylindrical lens which produces a 4- μm waist radius in one direction and does not change the 800- μm waist radius in the perpendicular direction. This slit-shaped spot is imaged by the scanning lens to a slit spot on the code plate.

VI. THE CODE PLATE

The code plate is a ruled grating having approximately 13,300 cycles. Each cycle consists of a 7- μm opaque region and a 7- μm clear region. The slit shaped coding beam is focussed in its narrow dimension to best resolve the grating. The long dimension of the beam is aligned to the ruling direction of the grating. In this manner, small defects in the grating, dust specks and pinholes do not significantly affect the code-plate system.

The coding beam will traverse the full-field angle over the scan of a line. In order to collect the coding beam onto a photodetector after it has passed through the code plate, a Fresnel lens is positioned beyond the code plate (see Fig. 1). This lens images the aperture of the scanning lens onto the face of a photomultiplier tube. The sensitivity of this device is required so that the coding beam can be attenuated

by approximately 20 dB before it illuminates the scanning lens. If this attenuation is not used, then the scatter from the intense coding beam fogs the photographic plate and reduces the modulation capable of being obtained with the writing beam alone.

The processing and use of the code plate output is described in Part III—The Control System. The alignment of the code plate for production of an accurate scan is described in Part IV—Alignment and Conclusions.

VII. ACKNOWLEDGMENT

The acoustooptic modulator, its driver and gating amplifier were designed and constructed by R. W. Dixon and R. V. Goordman.

REFERENCES

1. Born, M., and Wolf, E., *Principles of Optics*, New York: Pergamon Press, 1959, Chapter 8.
2. *Kodak Plates and Films for Science and Industry (P-9)*, Rochester, New York: Eastman Kodak Company, 1967.
3. Labuda, E. P., Gordon, E. I., and Miller, R. C., "Continuous Duty Argon Ion Lasers," *IEEE J. of Quantum Elec.*, *QE1*, No. 6 (September 1965), p. 273.
4. Fox, A. G., and Li, Tingye, "Resonant Modes in a Maser Interferometer," *B.S.T.J.*, *40*, No. 2 (March 1961), pp. 453-488.
5. Goubau, G., and Schwering, F., "On the Guided Propagation of Electromagnetic Wave Beams," *Trans. IRE, AP-9*, No. 3 (May 1961), pp. 248-256.
6. Abramowitz, M., and Stegun, I. A., *Handbook of Mathematical Functions*, National Bureau of Standards, 1965, Chapter 7.
7. Gordon, E. I., "A Review of Acoustooptic Deflection and Modulation Devices," *Proc. IEEE*, *54*, No. 10 (October 1966), pp. 1391-1401.
8. Kogelnik, H., "Imaging of Optical Modes—Resonators with Internal Lenses," *B.S.T.J.*, *44*, No. 3 (March 1965), pp. 455-494.

The Primary Pattern Generator Part II—Mechanical Design

By G. J. W. KOSSYK, J. P. LAICO, L. RONGVED and
J. W. STAFFORD

(Manuscript received July 10, 1970)

I. INTRODUCTION

The primary pattern generator (PPG) is an electromechanical light-scanning system with an unusual combination of speed and accuracy. A 10- μm -diameter light spot can be addressed successively to any or all points of a 26,000-wide by 32,000-long rectangular point array with 7- μm vertical and horizontal spacing in about ten minutes. This corresponds to a scanning rate of one spot per 600 nanoseconds. The light spot is placed repeatedly to an accuracy of about a $\pm 7\text{-}\mu\text{m}$ total accumulated error over the whole array, and the vertical and horizontal spacing between points is maintained within $\pm 1\ \mu\text{m}$.

The rectangular point array is scanned one line at a time at the rate of 53 lines per second by successive sweeps of a monitored laser beam across the width of the array interposed by 7- μm steps of the photographic plate in the perpendicular direction. The essential components of the scanning system are shown in Fig. 1. The laser generates a light beam which, by various stationary mirrors, is directed to the acoustooptic modulator. When this modulator is turned on, a small portion of the laser beam is slightly deflected and is denoted the write beam. The major portion of the light beam, called here the code beam, passes through the modulator with no directional change. When the modulator is turned off, the light beam passes through unchanged. The response time of the modulator is of the order of 10 nanoseconds which is very small compared to the 600-nanosecond period it takes the scanning beam to move from one addressable point to the next.

By further fixed mirrors and lenses, the code and write beam is brought to focus at neighboring points near the edge of the photographic plate.

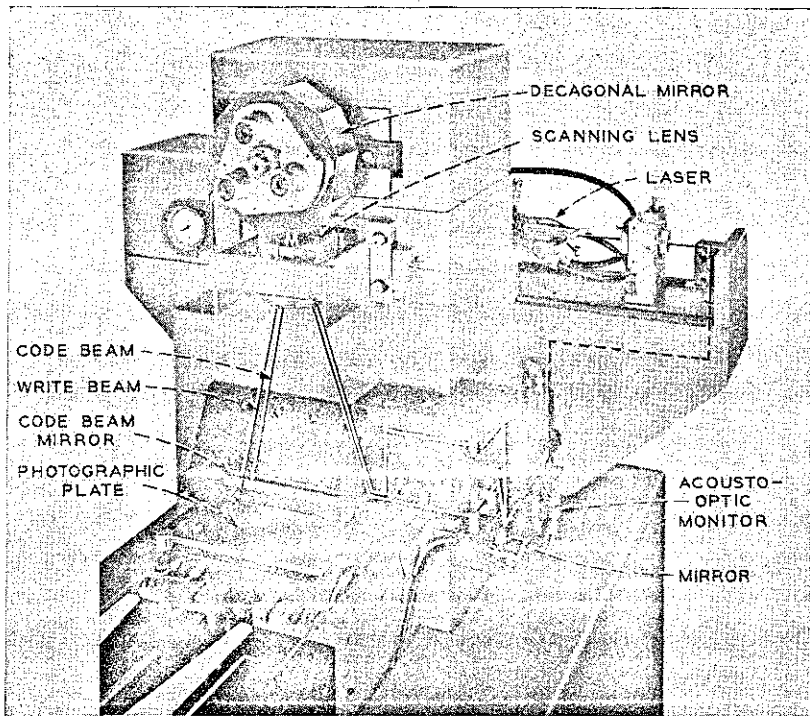

Fig. 1—Primary pattern generator.

By means of the scanning lens and the decagonal mirror, the focused spot of the write beam is imaged onto the photographic plate. The focused point of the code beam is, by the same means and one additional code beam mirror, imaged onto a code plate. The code beam is intercepted by the code plate except at $7.0\text{-}\mu\text{m}$ -wide transparent lines on $14\text{-}\mu\text{m}$ centers. The light passing through these transparent lines is collected in a photocell by means of a Fresnel lens. As the decagonal mirror turns, the two beams move together. The code beam, by pulsing the photodetector, yields positional information to the computer which, by means of the modulator, regulates the write beam on or off as required for proper exposure of the photographic plate.

The decagonal mirror spins at 300 rpm resulting in 53 write-beam sweeps per second. The 10 facets of the decagonal mirror are inclined to the mirror's radial symmetry axis at a very small angle which is identical for all facets within $\pm\frac{1}{2}$ of one second of arc. Furthermore, the mirror's radial-symmetry axis spins with a wobble less than 1/10

of one second of arc. Therefore, any sweep of the write beam when the photographic plate is fixed traces lines that are separated by no more than $\pm\frac{1}{2} \mu\text{m}$.

The 300-rpm speed of the decagonal mirror results in about 11-ms-duration sweeps across the photographic plate, with about a 7-ms-long period between the end of one and the beginning of the next sweep. The computer may write in every sweep, and the step system must be designed so that a step may be completed in the 7-ms period between sweeps. If the computer writes in every sweep, the table steps at 53 steps per second. If the computer cannot write in every sweep, one or more steps are skipped as required for the computer to catch up. This step motion is a sophisticated vibration-free one where each step is equal to the next within $\pm\frac{1}{2} \mu\text{m}$, and the total accumulative error over 32,000 steps is about $\pm 5 \mu\text{m}$ assuming temperature control within 0.2°C .

II. MATERIALS SELECTION

The material used for the major PPG structure is Meehanite GC40. This material was chosen for its great dimensional stability with time. To insure that the material was initially stress-free, a three-step heat treatment-machining sequence was used. Briefly:

(i) After casting

- (a) Heat to 1600°F . Hold 2 hours.
- (b) Cool to 1250°F at 35°F per hour.
- (c) Hold at 1250°F for 10 hours.
- (d) Cool to 200°F at $20\text{--}25^\circ\text{F}$ per hour.

(ii) After Rough Machining (allow $0.020''$ for final machining)

Thermally cycle: 210°F to 400°F to -120°F to 400°F to 200°F . Hold at -120°F and 400°F for 2 hours.
Final cooling to 200°F must not exceed 25°F per hour.

(iii) After Dual Machining

- (a) Heat to 300°F . Hold for 6 hours.
- (b) Cool to 200°F at $20\text{--}25^\circ\text{F}$ per hour.

The residual stress after heat treatment will not exceed 200 psi, resulting in a maximum relaxation strain of about 10 microinches per inch. Micro-creep tests conducted at Battelle Institute indicated that most of this relaxation occurs in the first four to six weeks which is before assembly of the pattern generator. Thus, only a few microinches per inch is expected during the life of the pattern generator.

III. TWO SPECIAL AXIAL ALIGNMENTS

Two very accurate axial alignments are made in the pattern generator. In one, the axis of an air bearing is aligned with the radial-symmetry axis of the decagonal mirror. In the other, the axis of the air bearing is aligned with the direction of motion of the step table. Both alignments use an elastic micromanipulator which was developed especially for the pattern generator. The alignments are essentially identical and only the decagonal mirror alignment is described here.

3.1 *The Elastic Micromanipulator*

The elastic micromanipulator is based upon a very elementary mechanical deamplification device. It consists of two springs that are connected in series and deflected against a support. In the static case, the total deflection of the spring, $\Delta\delta_1$, is related to the deflection of the interface of the springs, $\Delta\delta_2$, by the relationship

$$\Delta\delta_2 = \frac{k_1}{k_1 + k_2} = \Delta\delta_1$$

where k_1 and k_2 are the respective spring constants. The motion, $\Delta\delta_1$, is thus directly related to $\Delta\delta_2$ by the deamplification factor $F = k_1/(k_1 + k_2)$, which can be made as small as one pleases by choosing $k_2 \gg k_1$. In order to use such a device as a micromanipulator, one provides a fine screw to manually produce the deflection, $\Delta\delta_1$, and one attaches the body to be moved to the spring interface so that the corresponding body motion is $\Delta\delta_2$ as shown in the lower part of Fig. 2.

3.2 *Alignment of the Decagonal Mirror*

The adjustment for axial alignment of the decagonal mirror consists of three elastic micromanipulators placed 120° apart and equidistant from the symmetry axis. Between the face of the air-bearing spindle and one side of the mirror are the three stiff springs and, on the other side of the mirror directly opposite to these stiff springs, are the three soft springs which can be pressed against the mirror individually by three fine-adjusting screws.

The nature of the three stiff springs requires some explanation. The air-bearing face is machined with three raised $\frac{1}{4}'' \times \frac{1}{4}''$ areas as indicated in Fig. 3. The surface of these areas is finished machined with a stationary tool when the air bearing is spinning so that their surfaces lie in a plane normal to the air-bearing axis within about a second of arc. The decagonal mirror has an optically flat end face and this face

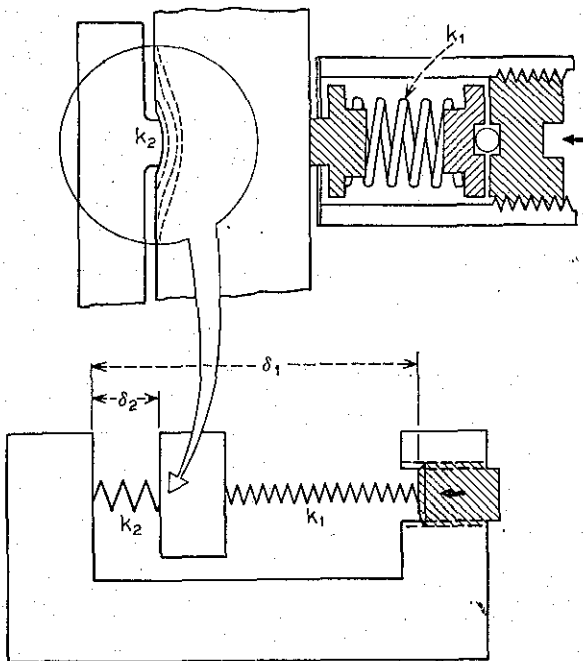

Fig. 2—Elastic micromanipulator.

is placed directly against these three pads. As the mirror is pressed against these raised areas by the soft springs on the opposite side of the mirror, the pads elastically indent the mirror as indicated on the upper part of Fig. 2. There is also some corresponding local indentation of the air-bearing face. Except for these small local regions of deformation, the mirror and the air bearing remain essentially rigid and the elastic deformation in the three small regions serves the purpose of the three stiff springs. The various mechanical elements are shown in detail in Fig. 4.

The relationship between the force exerted by the soft springs and the corresponding deflection of the stiff springs can be worked out from a classical elasticity solution due to J. Boussinesq. From this solution one can determine the effective spring constant associated with each of the three stiff springs. They are given approximately by

$$k_2 = 2 \cdot 10^6 \text{ lb/in.}$$

The soft springs on the opposite side have a spring constant given by

$$k_1 = 6 \cdot 10^3 \text{ lb/in}$$

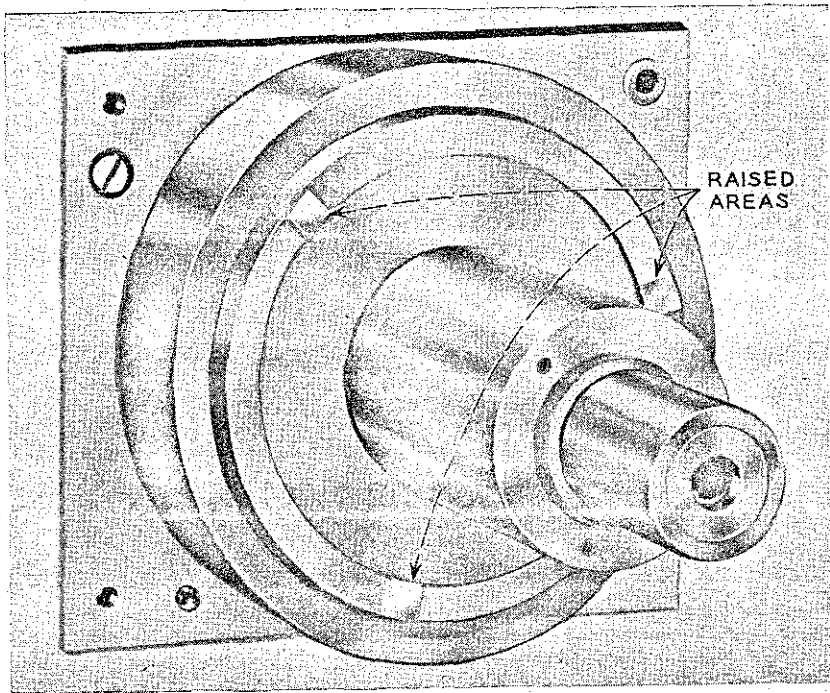

Fig. 3—Air-bearing spindle with raised areas.

and the amplification factor, F , works out to be about

$$F = 3 \cdot 10^{-4}.$$

The pitch of the adjusting screws is 40 turns per inch, and thus for one complete revolution of the adjusting screws the mirror will move about $18 \cdot 10^{-2}$ microns. When only one adjusting nut is advanced, the mirror will rotate about an axis passing through the two raised areas opposite the other two adjusting nuts. The raised areas are separated by about 7 cm, and thus the resulting rotation of the mirror equals about (0.6) second of arc per revolution of the adjusting nut. Since the adjustment is carried out together with an instrument to measure the mirror axis run out, there is no need to know this relationship exactly.

In the PPG, the mirror axis is aligned with the air-bearing axis to $\frac{1}{10}$ of a second, and we know that the adjustment remains stable to this accuracy over long periods.

When the mirror facets are measured to perform the final grinding operations, the mirror is aligned to $\frac{1}{50}$ of a second. This more precise

adjustment has been demonstrated to be stable over several days, but it has not been evaluated on a long-term basis.

IV. THE STEPPING SYSTEM

There are two simple and fundamental concepts involved in the pattern-generator stepping system. One of these is a special electronic drive for the step motor used in the mechanical drive of the stepping system. The other is tuning of the natural frequency of the second mode of motion of the mechanical drive. Together these two concepts permit vibration-free stepping in the absence of passive damping. There are also several practical problems involved in the construction of the step table. One describes here first the two simple concepts, next the problems of construction, and last some experimental results.

4.1 *The Special Electronic Drive*

In order to describe the special electronic drive, first one describes certain characteristics of the stepping motor. The motor torque, T , as a function of the angular position of the armature, θ , is shown in Fig. 5a for a given current in the two motor windings. The amplitude of the sinusoidally varying torque is called the holding torque. The hold-

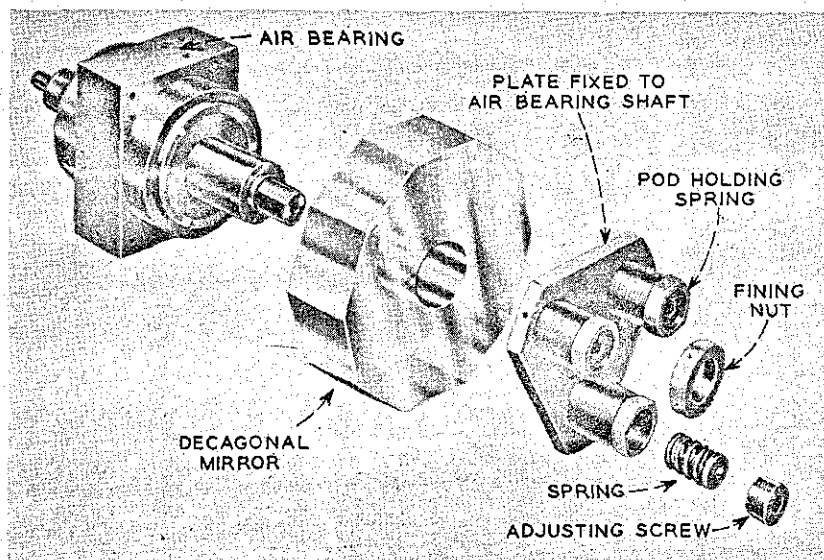

Fig. 4—Telescopic view of the decagonal mirror adjustment.

ing torque is proportional to the current in the motor windings. The magnitude of this current is usually kept constant, and only its direction is changed in the normal operation of the stepping motor. The effect of successively changing the direction of the current in each motor winding is indicated in Fig. 5b.

The mechanics of a simple operation of a stepping motor are essentially as follows: Assume the motor to be at rest in step position, n , which is one of the stable-equilibrium positions associated with the motor torque indicated by the solid curve in Fig. 6. Let the current be changed in one winding, thus bringing about the motor torque indicated by the dotted curve. The motor will now accelerate towards the step position $n + 1$ and, depending upon the damping in the motor, assumed less than critical, it will vibrate about the new position with decaying amplitude. This vibration is completely intolerable for the present application. Furthermore, if the motor is stepped continuously, vibration build-up from one step to the other occurs. To eliminate the vibration, the motor is provided with a special electronic drive. This drive provides three timed current settings for the motor per step which are applied as follows: Assume as before that the motor is at rest in position n as indicated in Fig. 6. The current is now reversed

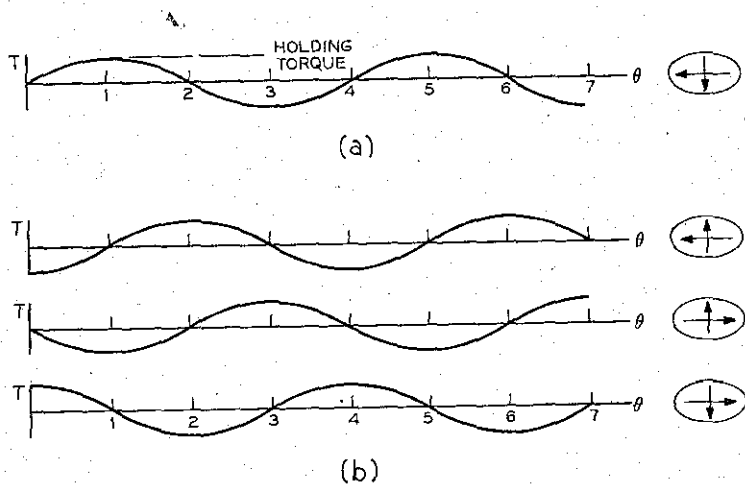

Fig. 5—Characteristics of the stepping motor. (a) $0, 1, 2, \dots, N$, are the step positions of the motor. $2, 6, \dots, (2 + 4l)$, where l is an integer, are equilibrium positions of the motor for a particular current direction in the two-motor windings as schematically indicated by the arrows in the ellipse on the right. (b) The motor torque as a function of theta is simply translated by one step each time the current is reversed in one winding.

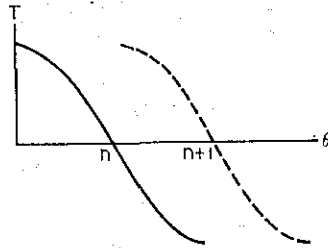

Fig. 6—Motor torque, T , as a function of angular position, θ .

in one winding for a timed period, t_1 , bringing about the motor torque indicated by the dotted curve. As before, this will accelerate the motor towards its new step position, $n + 1$. However, t_1 is adjusted such that at the end of this timed period the motor is at a point about half way between n and $n + 1$, and it is of course still moving. The current is now reversed again in the same winding for another time period, t_2 , bringing about the torque indicated by the solid curve in Fig. 6. This torque decelerates the step motor until it stops, and t_1 and t_2 are timed such that the point at which the motor stops coincides with the new step position, $n + 1$. The current in the same winding is now reversed a third time, producing the motor torque indicated by the dotted curve. This third current setting will hold the motor in the new equilibrium position until one wishes to make another step. This stepping technique produces vibration-free stepping without passive damping. Such an electronic device has been used previously in Bell Laboratories for a magnetic tape drive.

4.2 A Tuned Two-Degrees-of-Freedom System

In the previous description of the special motor drive it was tacitly assumed that the stepping motor and all that it drives behaves as a single-degree-of-freedom system, i.e., that the motion of all bodies involved can be determined from a single independent variable. This state exists if such things as backlash, elastic deformation of parts, etc., are negligible. If the time to complete a single step is made sufficiently long, say by decreasing the motor torque, our step system will behave sensibly as a single-degree-of-freedom mechanical system involving only rigid-body motion. However, if the time to complete a step is made short enough as was the case in the pattern generator, one will also excite noticeable motion involving elastic deformation in components of the system. One is then confronted with a much more

complicated multidegree-of-freedom mechanical system. Specifically, there was one deformational mode of motion that could not be eliminated. The special motor drive does not then by itself yield vibration-free stepping. One describes here how we were able to control this deformational mode by tuning its natural frequency.

The stepping table is shown in Fig. 7. It consists of a stepping motor driving the shaft of a ball-lead screw, a thrust bearing preventing axial motion of the shaft relative to the rigid base, a step table on linear roller bearing ways and driven by the nut of the lead screw. There are two modes of motion that come into play in this stepping system: (i) The motion in which all bodies remain rigid and involving shaft rotation and linear table motion as constrained by the lead-screw pitch. One denotes this mode the ideal rigid-body mode. (ii) The mode of motion where the table, as in the first mode, moves as a rigid body on

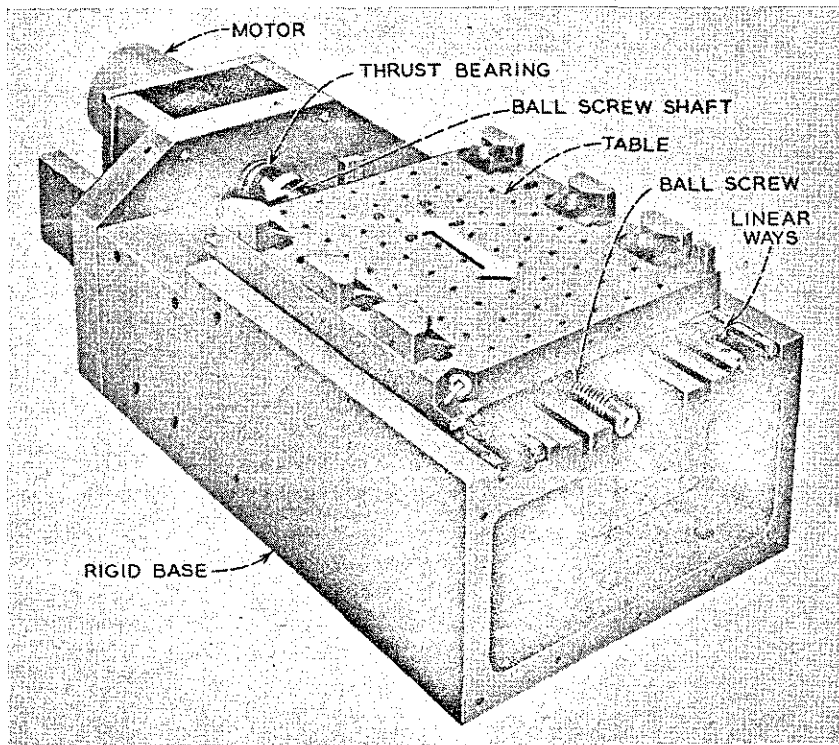

Fig. 7—Stepping system.

its ways but now as a result of elastic deformation primarily of the Hertz type that occurs in the balls and races of the lead screw.

A simple analysis of this two-degrees-of-freedom system reveals an interesting characteristic, namely, that by an adjustment of the natural frequency of the second mode of motion, the special electronic motor drive will step the table with no vibration in either mode. Subsequent experiments proved that such mechanical tuning is a practical matter. In order to describe the essential mechanics involved, some aspects of the simple analysis are given here.

Because of special mechanical characteristics of the step table the two modes of motion mentioned above, namely, the ideal rigid-body mode and the mode involving deformation in the ball screw, are very nearly the normal modes of the system. Therefore, the shaft rotation under the action of the motor torque is sensibly unaffected by the elastic deformation in the ball screw and can be calculated quite accurately, taking only the rigid-body mode into account. The second mode of motion can be equally accurately calculated, taking it to be a single-degree-of-freedom system whose support is given an inexorable motion identical to the table motion associated with the rigid-body mode. The equations for this determination of the first and second mode are

$$T = I\ddot{\theta},$$

$$x_0 = \frac{p}{2\pi} \theta,$$

$$\ddot{x} + \ddot{x}_0 = -\omega^2 x,$$

where T is the motor torque, I is the sum of the rotatory inertia of the motor and lead-screw shaft plus an equivalent table rotatory inertia, θ is the angular position of the motor, x_0 is the first-mode table motion, x is the second-mode table motion, p is the lead-screw pitch, ω is the circular natural frequency of the second mode, and dots indicate time derivatives. One assumes now first that the motor torque is a constant over the acceleration period t_1 and the same constant with negative sign during the deceleration period t_2 . Secondly, one assumes $t_1 = t_2$ and that the constant torque is selected so that \dot{x}_0 is zero when x_0 is increased by one step, i.e., the special drive is adjusted to give no vibration in x_0 at the end of a step. Lastly, one assumes that x and \dot{x} are zero at the beginning of a step. One obtains then for the amplitude of vibration

in the second mode, A ,

$$A = \bar{x}_0 \frac{\sin^2(\pi f \bar{t}/2)}{(\pi f \bar{t}/2)^2}$$

where \bar{x}_0 is the length of one step, $f = \omega/2\pi$, and $\bar{t} = t_1 + t_2$. One notes now that $A = 0$ when $f\bar{t}/2$ is an integer. According to this simple analysis, there should be no vibration if $f = 286$ cps when $\bar{t} = 7 \cdot 10^{-3}$ s as required in the pattern generator. This frequency corresponds closely to the frequency determined both experimentally and from a more rigorous numerical analysis at which vibration was found to vanish. The vibration amplitude, A , is plotted in Fig. 8 as a function of f . This curve reveals another important point, namely, that where A is zero, the slope of the curve is also zero. For that reason, there is no need to adjust the frequency of the second mode accurately to effectively eliminate vibration, which would have been impractical. One notes that the above solution applies to continuous stepping only when $f\bar{t}/2$ is an integer since only then are x and \dot{x} zero at the beginning of each step. If vibration in x occurs, one has to contend with vibration build-ups from one step to the next.

The rigid-body mode, $f = \infty$, is plotted together with the actual table motion in Fig. 9. The difference between these curves is essentially due to motion in the second mode. One notes that the second mode, as the first, is excited only during the times t_1 and t_2 , and no subsequent motion occurs until the table is stepped again.

4.3 Some Practical Problems of Construction

Several problems were encountered in the construction of the step table to make it, in fact, behave as the two-degrees-of-freedom system analyzed. A major problem was to reduce the number of degrees of freedom of the system to two. This was done by increasing the natural frequency of the various other modes to a point where the step motion would not noticeably excite them. Our effort in this respect is reflected in the very massive and stiff structure of the pattern generator.

Of particular interest also is the very massive support for the thrust bearing, noticeable in Fig. 7. A particular thrust bearing was selected which enabled us to get rid of a very objectionable third mode of motion in which the ball-screw shaft would move axially by elastically deforming the thrust bearing and its support. A very difficult problem was to find lead screws with a combination of high stiffness of the nuts axial deformation relative to the shaft and low-frictional torque. We found ball-lead screws to be far superior in this respect to lead screws with acme threads.

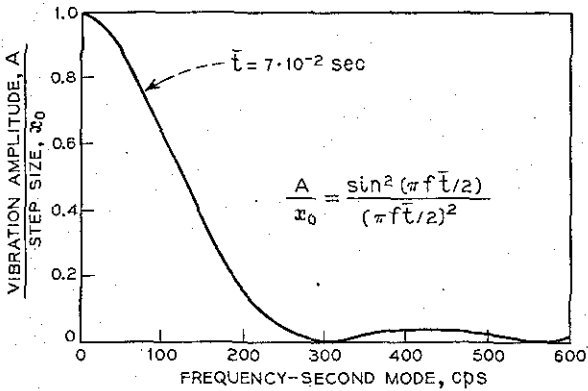

Fig. 8—Vibration amplitude, A , of the second mode as a function of its frequency for a fixed step time, $\bar{t} = 7$ ms.

4.4 Lead Screw Life Tests

One of the most critical mechanical requirements of the PPG is that the drive train of the system have a sufficiently long life so that many years of product can be made without changing essential items which would affect the reproducibility accuracy of the system. One sees from Fig. 8 that a drive train-table combination whose stiffness yields a frequency of about 280 cps is desirable. To insure step accu-

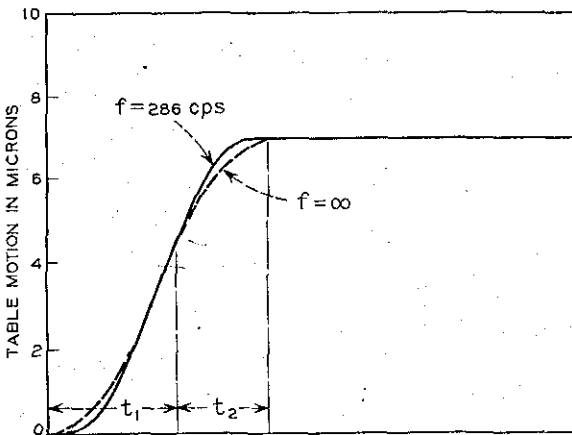

Fig. 9—Ideal rigid-body mode, $f = \infty$, superimposed on the actual table motion, $f = 286$ cps. The discrepancy between the two curves is very nearly the motion of the second mode. One notes that both modes are excited during t_1 and t_2 , but no motion persists in either mode once a step is completed.

racy, it was desired that the stepping-system stiffness be great enough to yield a frequency of 280 cps and the frictional torque should be considerably lower than the stepping-motor holding torque so as to minimize step error due to friction. A preload of 25 pounds on the ball screw was found to yield the desired system stiffness and torque to break static friction.

The test setup used to establish the life test of the mechanical components of the drive train is shown in Fig. 10. The life-test setup duplicates the essential features of the PPG drive train.

The status of the life-test equipment was monitored by periodically checking the torque to break static friction and the stiffness of each system. The stiffness was measured by determining the rigid-body resonant frequency of the drive train-table combination and then calculating the stiffness. The stiffness was also checked occasionally by statically measuring the drive-train stiffness by applying a known load and measuring the table deflection relative to the thrust-bearing support.

One sees from Fig. 11, which is typical of the data taken, that there has been a pattern of decreasing torque-to-break static friction. Similarly, from Fig. 12, the stiffness measurements for the units have shown a tendency to increase with time.

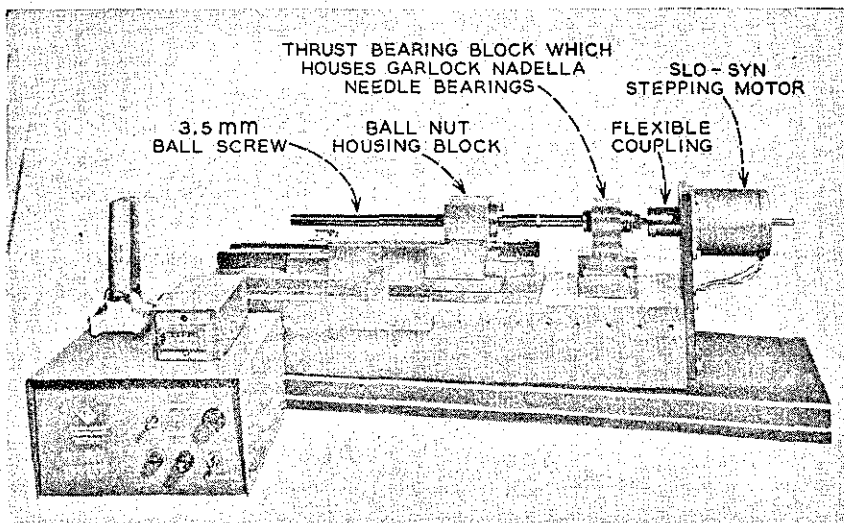

Fig. 10—Typical life-test setup.

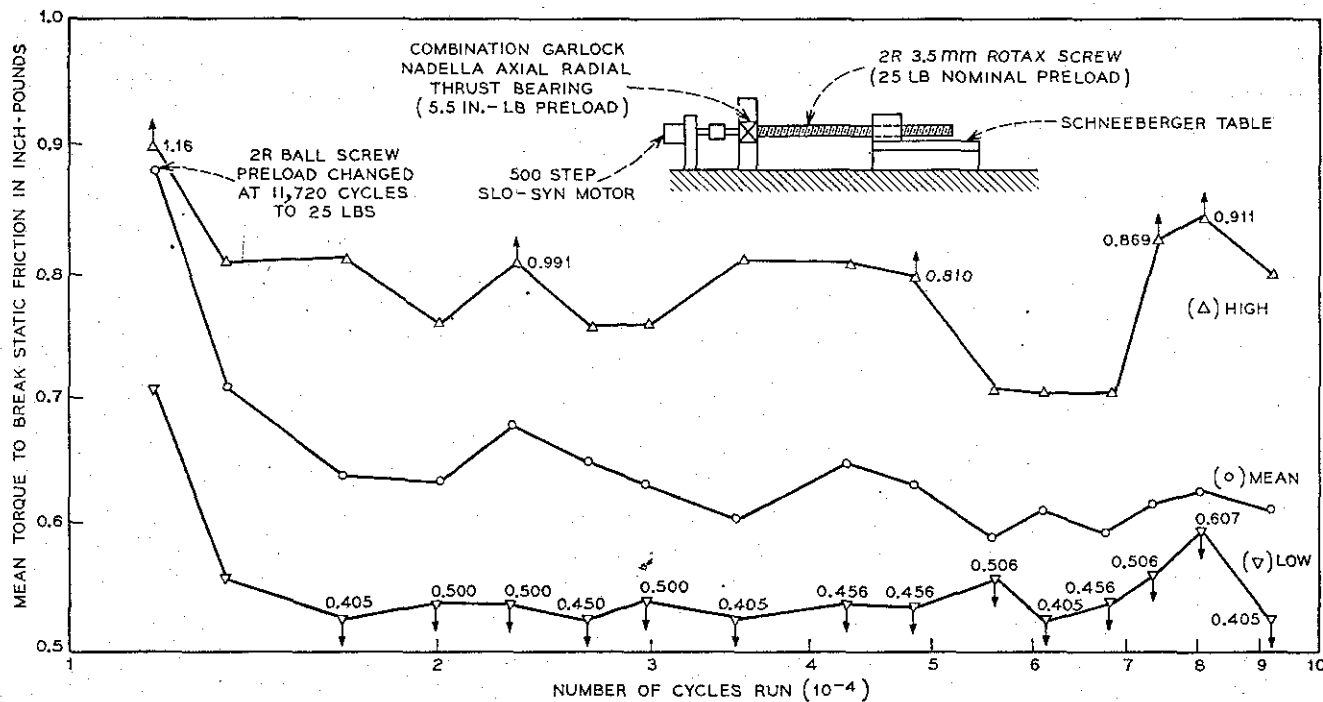

Fig. 11—Mean torque-to-break static friction versus cycles run on 2R life-test setup. Note: 1. Distance traveled per cycle = 19"; 2. Time per cycle = 190 s.

During the life test, a decrease in torque and an increase in stiffness can be attributed to the fact that the screw and bearings are being burnished (i.e., worn in) and hence, the riding surfaces are more uniform and smoother. Furthermore, as things become smoother, more balls of the ball screw and needles of the thrust bearing become fully effective.

4.5 Stepping Test Measurements

The accuracy of the step table as determined experimentally is briefly as follows: Steps are reproducible to $\pm 1/4 \mu\text{m}$. This reproducibility accuracy is primarily the result of some unavoidable coulomb friction in the drive and a small amount of vibration about the equilibrium position. The absolute accuracy of steps is such that all steps are equal within $\pm 1/2 \mu\text{m}$.

Experimental determination of the table motion as a function of time is given in Fig. 13.

Straightness of table travel with minimal transverse and rotary motions is necessary to achieve reproducibility of spot positions on the photographic plate. A table mounted on preloaded roller bearings was employed to achieve the required accuracy. Measurements showed that

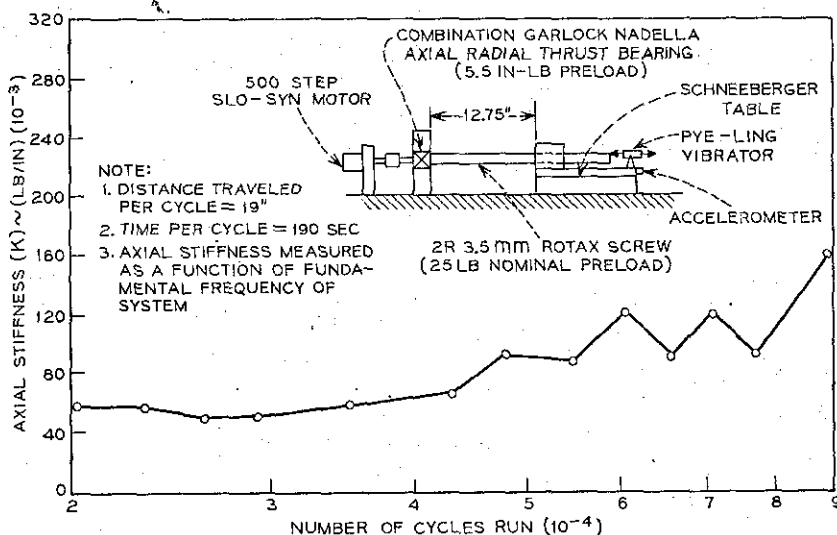

Fig. 12—Axial stiffness of 2R life-test setup versus cycles run. Note: 1. Distance traveled per cycle = $19''$; 2. Time per cycle = 190 s; 3. Axial stiffness measured as a function of fundamental frequency of system; 4. Axial stiffness measured directly, using a federal gage to measure table deflection (Δ).

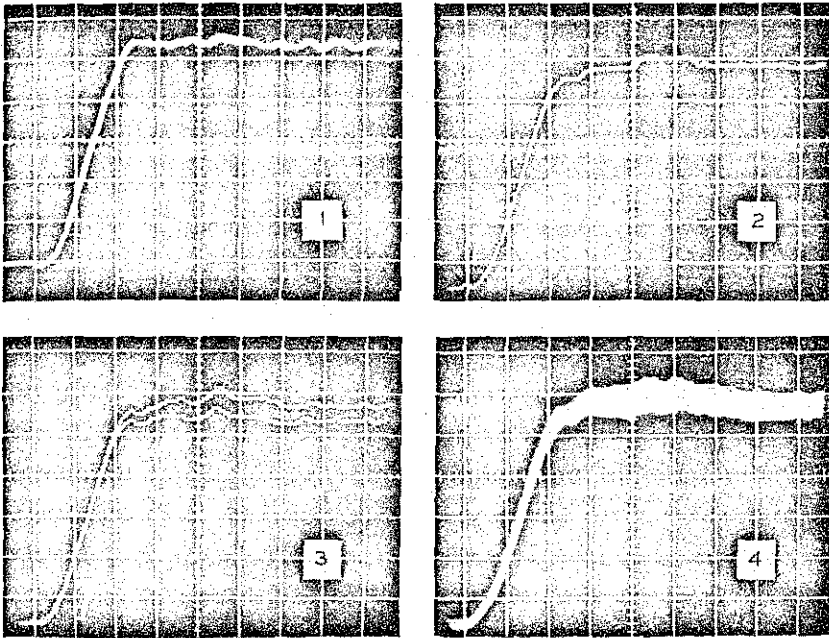

Fig. 13—Table displacement as a function of time. In the above figures, the table displacement was obtained with a laser interferometer having its digital output converted to an analogue output. The scale of the horizontal axis is 2 ms per division, and the vertical axis is $1.34 \mu\text{m}$ per division. Nominally, the table is to step $7 \mu\text{m}$ in 7 ms. The very small steps noticeable in the curves are single counts of the laser interferometer representing a displacement of about $0.079 \mu\text{m}$. The first two curves each show a single step. The difference between them shows the effect of variations in friction and axial stiffness along the length of the ball screw. The third figure shows two successive steps. The discrepancy between them represents error introduced by the stepping motor. The fourth curve shows 50 successive steps.

the rotational motion superimposed on the translational motion was less than 10 seconds of arc and that the transverse motion was about one micron.

V. ACKNOWLEDGMENT

The authors wish to acknowledge J. W. West's contribution to the fundamental ideas involved in the stepping system and decagonal mirror adjustment.

The Primary Pattern Generator Part IV—Alignment and Performance Evaluation

By A. M. JOHNSON and A. ZACHARIAS

(Manuscript received July 10, 1970)

I. REQUIREMENT FOR ALIGNMENT

The mechanical nature of the primary pattern generator (PPG) requires a precise juxtaposition of most of the machine elements in order to achieve both pattern accuracy and reliable functioning of the machine. Part II described the alignment of the rotating polygonal mirror to the air-bearing axis. The precision required in that assembly is the tightest tolerance in the PPG. This precision is required to produce a uniform scan-line spacing on the pattern. In addition, the direction of that scan line must be made as perpendicular as possible to the travel direction of the photographic plate. Therefore, the carriage of the photographic plate must move without rotation. The method for aligning the polygonal mirror axis to the carriage direction will be described, as well as other alignment needed to produce an accurate pattern. The code-plate system for controlling the fast scan was described in Parts I and III. Implicit in this description was the assumption that the code-plate grating and the photographic plate are the exact same distance from the scanning lens (see Fig. 1 in Ref 1). The positioning of the code plate to achieve accurate length of the fast scan is a critical alignment that requires a combination of optical and electronic techniques.

The accuracy goal for the PPG was 100 parts per million (ppm) deviation from an absolute coordinate system, the error reference being the overall dimension of the full PPG field. Thus the coordinate axes of the pattern must be orthogonal to within 20 seconds. A second of arc is approximately 5×10^{-6} rad. The photographic-plate position is determined by a lead screw as described in Part II. The accuracy of this

screw is the determining factor in the overall length error of the plate translation axis. For convenience, we will refer to this axis as the Y -axis and the fast scan axis as the X -axis.

The functional alignment includes positioning the optical modulator, obtaining separation of the coding and writing beams, positioning of the scanning lens, and positioning of various other lenses and mirrors in the optical paths of the two beams. The design and alignment of the laser cavity is described. The long-term functioning of the PPG will require replacement of the laser discharge tubes. Our design-and-alignment procedure allows tube replacement without realignment of the remainder of the optics.

II. FUNCTIONAL ALIGNMENT

The quartz laser tube is clad with a water-cooling jacket and is rigidly mounted within a solenoid which provides the axial magnetic field. By placement against pins, this assembly is located precisely on a flat plate on which the cavity mirrors are rigidly mounted. This system was devised so that a remotely located reference cavity can be used to prealign a laser-tube-solenoid assembly to the laser cavity on the PPG. The use of the reference cavity significantly reduces the down time of the PPG during laser replacement; replacement of the laser does not require realignment of the PPG.

The laser cavity is of a nearly hemispherical configuration consisting of a 0.9-m radius highly reflecting mirror and a flat, transmission mirror at the output. The separation is 0.75 m. The output is constrained to the TEM_{00} mode by using a 2-mm aperture inside the cavity near the spherical mirror. The 514.5-nm line is selected by the transmission characteristic of the output mirror.* The output mode of the laser has a $1/e$ -amplitude radius² of 200 μm . The train of lenses and mirrors (see Parts I and II) which is used to direct the laser output to the optical modulator was aligned by autoreflexion at each mirror. The lenses were inserted after the beam had been correctly positioned. Back reflections from each lens were used to center accurately that lens.

The optical modulator must be positioned to the Bragg angle.³ The angle is set by periodically exciting the modulator and then detecting the deflected beam with a photodetector and maximizing the modulation. After the modulator is positioned, the writing-beam separation

* The reflective band of the transmission mirror is centered near 550-nm wavelength. The edge of the band is at 514.5 nm and thus the reflectivity at all the other spectral lines is insufficient for oscillation.

mirror (see Part I) is positioned. A 10-cm focal length lens placed at the modulator output produces the required spatial separation of the writing and coding beams. At the separation mirror each beam has a $1/e$ -amplitude radius of $50 \mu\text{m}$ and the center-to-center beam spacing is $400 \mu\text{m}$. At this location, the coding beam is 20 to 50 times the intensity of the writing beam. The light from the coding beam which is scattered in the writing beam direction is removed by an 0.75-mm aperture placed concentric with the writing beam. Slight tilting of lenses eliminates objectionable back reflections. After these adjustments, the on-off ratio of the writing beam is greater than 50.

III. ACCURACY ALIGNMENT

The path of the writing beam from the modulator to the scanning lens (see Fig. 1 of Ref. 1) is determined by three adjustable mirrors in addition to the writing beam separation mirror. These three mirrors are used to properly direct the writing beam into the scanning lens. However, the proper position of the scanning lens is determined partly by the positions of the rotating mirror and photographic plate. Consequently, the rotating mirror must first be aligned to the photographic plate; then the writing-beam illumination of the scanning lens can be set and finally the scanning lens is positioned.

The alignment between the rotating polygonal mirror and the translational direction of the photographic plate (Y -axis) is accomplished by use of a precision cube and an autocollimator. The cube is mounted on the photographic-plate carriage in such fashion that a cube face is normal to the Y -axis. Errors are introduced by the yaw, pitch and roll of the carriage; each contributes a few arc seconds of error. First, two faces of the cube are indicated parallel to the Y -axis by using sensors capable of detecting $1/40 \mu\text{m}$ displacement. The cube face normal to these two faces is normal to the Y -axis. The X -axis of the pattern is the intersection of a plane normal to the axis of rotation of the polygonal mirror (this plane is also normal to all of the facets of this mirror) and the plane of the photographic plate. The plane of the photographic plate must be parallel to the Y -axis or else the X -axis as defined above will not always be in the focal plane of the scanning lens. A sufficient, but not necessary condition for the X -axis to be normal to the Y -axis is to make the carriage travel direction parallel to the rotation axis of the polygonal mirror. This is accomplished by using an autocollimator to set the reference face of the polygonal mirror (the reference face is perpendicular to all the facets of the mirror) parallel to the face of the precision cube which is normal to the Y -axis.

The actual angle between the X - and Y -axes was determined by generating a test pattern on the PPG and measuring this pattern with a coordinate-measuring machine (CMM).⁴ This measurement could be made with an error of less than 3 s. Thus, a correction to the direction of the rotating mirror was determined and used to reset the X -axis. Since this correction was less than 20 s, no other alignment was disturbed.

After the initial positioning of the rotating-mirror axis, the writing beam must be directed to the center of the entrance pupil of the scanning lens. This is set by autoreflecting the writing beam from a properly positioned polygonal mirror facet. The proper angle of the facet is calculated from the parameters of the scanning lens. The polygonal mirror facet is exactly positioned by the use of an autocollimating theodolite. The position which must be taken by the axis of the scanning lens is now fully constrained. This position is duplicated by a helium-neon laser beam which is positioned normal to a facet of the polygonal mirror. This facet is first set parallel to the X -axis. The He-Ne laser beam is also passed through the center of the scan line on the photographic plate. The scanning lens is positioned by centering its back reflections of the He-Ne laser beam thereby aligning the axis of the scanning lens with the He-Ne laser beam.

The last step in the X -axis alignment is the length-accuracy adjustment of the code-plate position. To accomplish this, a replica of the code-plate grating is produced by contact printing onto a photographic plate. This plate is then positioned in the PPG in exactly the manner a photographic plate is positioned when it is to be exposed. A long, silicon PIN photodetector is placed under the replica grating. The focused writing beam will produce a signal output from the PIN photodetector as it sweeps across the replica grating. However, the long photodetector has very little bandwidth. To circumvent this photodetector deficiency, the output of the actual code plate is used to modulate the writing beam by feeding the code plate signal into the optical modulator. Now the long photodetector under the replica grating will only have to respond to the beat frequency between the code-plate signal and the writing beam sweeping the replica. By adjusting the beat frequency to zero throughout the scan, the exact position registration between writing and coding beams is obtained. This method of alignment resulted in less than 10-ppm error in the X -axis length. Residual errors are caused by camber of the photographic plates (see Part I), inevitable temperature variations, and camber in the coding-beam output mirror (see Fig. 1 of Ref 1).

IV. PERFORMANCE EVALUATION

The design and fabrication of the necessary high-frequency mechanical components allowed the synchronization between the fast scan and the photographic-plate translation to be accomplished by a simple, computer-controlled system. Further, this step-on-command system allows flexibility in the computer control so that future work can produce a more economical division of work between the PPG control computer and the PPG postprocessor.⁵ At present, very few of the patterns drawn by the PPG have required the machine to wait for the computer to finish assembly of a line.

The rotating mirror presented the most critical item in terms of tolerance. The periodic bunching and spreading of the scan lines caused by the nonideal mirror results in both a periodic variation in the optical density of exposed regions and a periodic displacement in feature edges which are parallel to the Y -axis. The optical density variation is lost when the pattern is photographed by the reduction cameras. However, the periodic displacement is still detectable after the first reduction; the peak-to-peak amplitude is less than one-third address.

The major inaccuracy in the PPG is the Y -axis length. The lead screws used are accurate to within 15 ppm at 20°C. However, the lead-screw temperature in the operating machine is 25°C and so the Y -axis length is in error by 90 to 100 ppm. However, the lead screws can be replaced and this error can be eliminated.

The measured reproducibility of the PPG cannot be separated from the reproducibility of the coordinate-measuring machine. It was found that remeasurement of a PPG plate on the CMM produced readings which showed a variance of one-third address at the extremes of the pattern field. Near the CMM reference point in the pattern, the variance of the readings was approximately one-sixth address.⁴ Such behavior indicates a systematic error such as that caused by temperature differences. If the reproducibility of the CMM is accounted for, the variance in the location of a PPG-produced feature is not greater than one-third address and may be less than one-fourth address. Figure 1 shows the measured scatter of identical features drawn on 18 separate plates made over a period of two months. The (X, Y) address location of the CMM reference was (1000,1375) in the PPG field. The scale on the axes of the scatter plots are in addresses with respect to the absolute coordinate. Note the error increase in Y caused by the excess length of the Y -axis.

The PPG, as constructed, meets all of the requirements set by the mask-making system.⁶

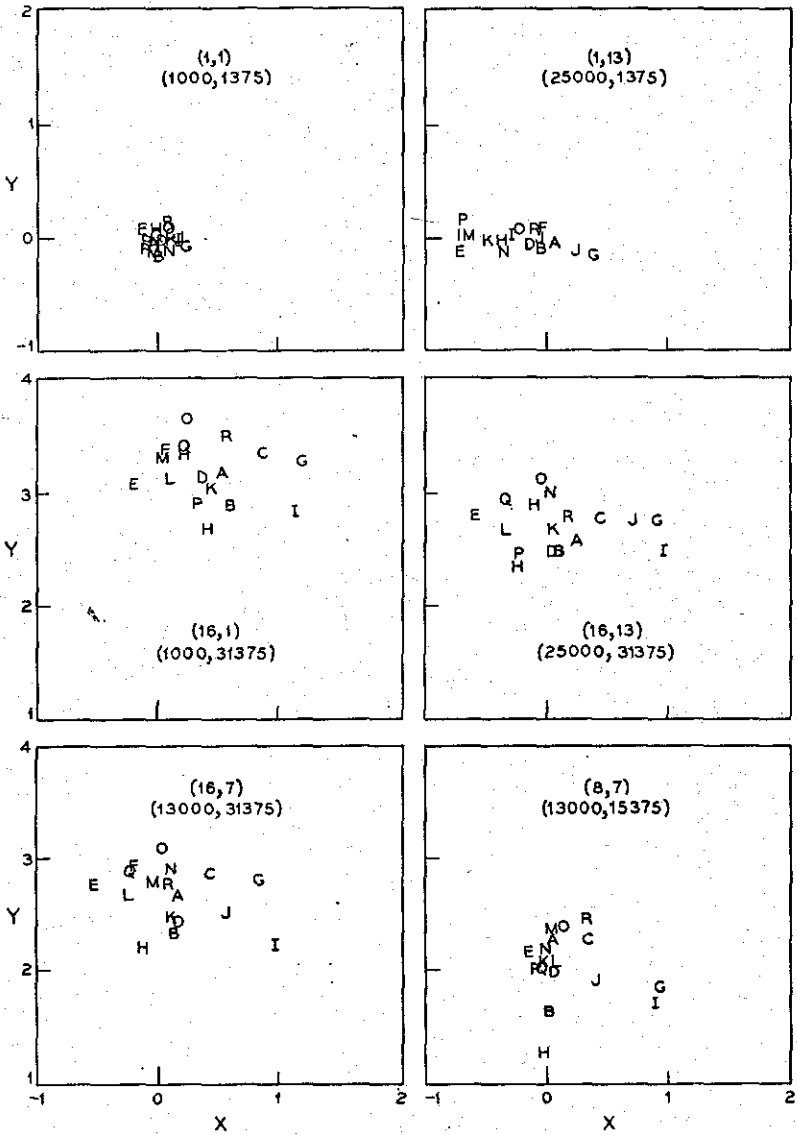

Fig. 1—Reproducibility of pattern generator.

V. ACKNOWLEDGMENT

A. D. White computed the illumination angle for the scanning lens.

REFERENCES

1. Cowan, M. J., Herriott, D. R., Johnson, A. M., and Zacharias, A., "The Primary Pattern Generator, Part I—Optical Design," B.S.T.J., this issue, pp. 2033-2041.
2. Kogelnik, H., "Imaging of Optical Modes—Resonators with Internal Lenses," B.S.T.J., 44, No. 3 (March 1965), pp. 455-494.
3. Gordon, E. I., "A Review of Acoustooptic Deflection and Modulation Devices," Proc. IEEE, 54, No. 10 (October 1966), pp. 1391-1401.
4. Ashley, F. R., Murphy, Miss E. B., Savard, H. J., Jr., "A Computer Controlled Coordinate Measuring Machine," B.S.T.J., this issue, pp. 2193-2202.
5. Gross, A. G., Raamot, J., Watkins, Mrs. S. B., "Computer Systems for Pattern Generator Control," B.S.T.J., this issue, pp. 2011-2029.
6. Howland, F. L., and Poole, K. M., "An Overview of the New Mask-Making System," B.S.T.J., this issue, pp. 1997-2009.

Device Photolithography:

Lenses for the Photolithographic System

By DONALD R. HERRIOTT

(Manuscript received July 10, 1970)

The edge definition, maximum complexity and accuracy of details in photolithographic masks are limited by the performance of the lenses in the system. The tolerances on exposure, sensitivity and uniformity of the photosensitive materials, and processing are dependent upon the images formed exceeding the minimum quality required. The lenses in this system have been designed and fabricated to achieve the best practical performance at this time in order to obtain the largest tolerances possible. This paper details the design parameters chosen, the constructions used and the performance obtained by each of the lenses in the system.

I. INTRODUCTION

There are two classes of photographic mask-making systems. In the first class, the pattern is generated through a lens as in a cathode-ray-tube plotter or primary pattern generator (PPG), or a lens is used to reduce the size of the pattern to that of the circuit being made. The maximum complexity of pattern in this type of system is limited by the resolution that can be obtained over the field of a lens.

A second class of systems uses a lens imaging a single small spot of light that is moved over an area and modulated to write a pattern. In this type of pattern generator the complexity of pattern is limited only by the minimum spot size and the area covered. This system must be used to draw the mask at the same scale as the final circuit or the lens in a reduction camera would limit the resolution.

Systems in the first class have been chosen for the mask laboratory in spite of the resolution limitations because of the speed and flexibility of the lens type systems for making a wide variety of masks. As a result the lenses in the system are the principal limitation on the maximum complexity of patterns that can be produced and on the quality of the images.

The performance of lenses is limited by the wavelength of light, the aperture of the lenses, and the aberration correction of the lenses. The wavelength of visible light is about half a micron, and it is theoretically possible to obtain light distributions in an image having cycles of light and dark of about one-half-micron width. Blue light can be imaged with better resolution because it has a shorter wavelength than green or red light. The wavelength that can be used in making masks is limited by the sensitivity of the photographic materials, the available light sources and the transmittance of the glasses used in the lenses and as a substrate for the photosensitive materials.

The resolution is also limited by diffraction. It would be necessary to bring light to the image from a cone subtending an angle of 180° to resolve spatial images with periods of one wavelength. A smaller angle of light to an image will limit the resolution to larger detail. The large apertures of the lenses used in this system are required for resolution of the detail in the masks rather than to collect light.

The resolution of a lens may also be limited by aberrations. A single lens element with spherical surfaces will not image the light passing through it from a point in the object to a point in the image. Aspheric surfaces could be used to do this for a point on the axis of the system but not for points off axis. These defects in the imagery can be greatly reduced by combining many elements designed to compensate for the aberrations. It is not possible to reduce these aberrations to zero but they can be made smaller than the diffraction effects by using complex combinations of lenses.

II. MODULATION TRANSFER FUNCTIONS

A convenient measure of the quality of an optical image is the modulation transfer function (MTF). This is a curve of the contrast that is obtained in the image of a sinusoidal intensity target as a function of the spatial frequency of the target. Figure 1 shows a series of MTF curves for perfect lenses of various aperture ratios. The MTF varies from 0 to 1.0 and is the ratio of the contrast in the image to that of the target. The spatial frequency scale is in cycles per mm and covers the general range of interest in mask-making systems. As you can see in Fig. 1, the smaller the f /number, the better the contrast and the higher in spatial frequency it extends. Thus, to get a high quality image of 25μ lines in a reduction camera may require only an $f/8$ cone angle to the image, but good 1μ lines in a step-and-repeat camera require a lens of $f/2$ or faster.

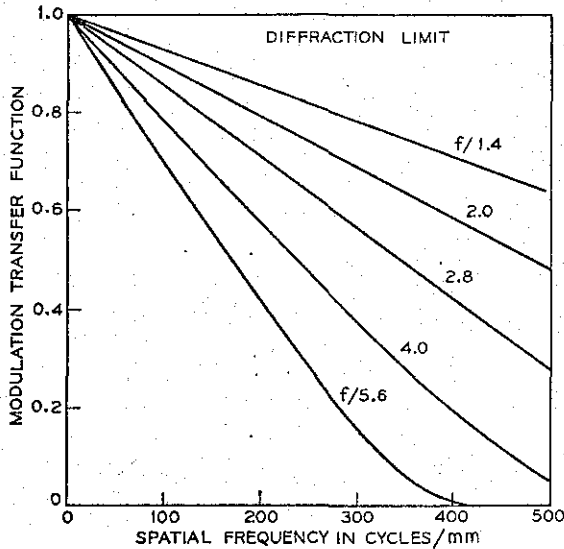

Fig. 1—MTF as a function of spatial frequency in an image formed by a cone of light of the indicated "f" number.

This requirement for low "f" numbers for high resolution may seem strange to those who are used to stopping down the lens to get a sharper image. This is because conventional camera lenses are limited in performance by their aberrations and stopping down the lens reduces these aberrations. The best resolution is probably obtained at about $f/8$; the image gets poorer when stopped down beyond that because of the diffraction limits shown in the MTF curves. Photographic lenses are often used in low-light conditions and the value of the increased speed obtained by increasing the aperture is more important than the loss in resolution caused by the aberrations.

In contrast, the large apertures of lenses for mask-making systems are almost always picked for resolution rather than speed. It is therefore necessary to reduce the aberrations to values that are small in comparison to their diffraction effects. There is still a compromise region. A lens for a 2.5μ linewidth mask should have an MTF of over 60 percent at 200 cycles/mm. This could either be obtained with a perfect $f/4$ lens or an $f/3$ lens with some aberrations. It could also be obtained with an $f/2$ lens with larger aberrations but unless the exposure speed of the lens were critical, the greater complexity of the

$f/2$ lens would make it more expensive and prone to larger errors in fabrication.

A second reason to select the smaller aperture is its increased depth of focus. When projecting an image directly onto a non-flat silicon wafer, this can be of major importance. In making masks on glass it determines the flatness tolerance; in all cases it determines the accuracy to which the cameras must be focussed and the stability of this focus.

III. SYSTEM CONSIDERATIONS

The lenses used in this mask-making system have been designed for practical operation in a production system. The parameters have been selected to advance the state of the art in each area and to obtain the largest tolerance possible in each operation of the mask system.

The performance of each part of the system is limited by the lens. The 26,000 address width of the pattern generator field is near the maximum that can be obtained with the aperture limits of the scanning system. The 5000 linewidth square field of the step-and-repeat camera is even more challenging to the lens designer for the small image involved. The reduction-camera lenses are not as difficult but have been designed for higher performance and therefore greater tolerances in use.

All of the lenses have been designed without major consideration of cost as even small improvements in performance would result in operating savings in excess of any reasonable cost.

IV. LENS DESIGN

The design of specialized lenses of this type is far ahead of the ability to manufacture them with uniform quality. In recent years automatic lens design programs have been developed which efficiently find the optimum design from each starting point while placing the desired importance on each characteristic. For instance, it has been found that designs of the types used are capable of essentially zero field distortion. It would be difficult using manual design techniques to find designs completely free of distortion. With automatic design programs, a small weight on distortion will cause new designs to be selected by the programs that are free of distortion until it is necessary to compromise other characteristics. The designer can then see just what must be sacrificed in one characteristic for gain in the other.

It is either necessary for the lens designer to learn all of the other parameters of the mask system or for the system designer to under-

stand the lens design difficulties to arrive at suitable system compromises. The development of automatic design programs has made it reasonable for the system designer to explore the design of the lens while designing the system. A variety of lens designs for the lenses of this program were explored by the systems designer although the final lenses were designed and constructed by an experienced lens design group at Tropel, Inc.* In this manner, the system parameters were selected, a suitable performance target could be determined, and a tentative choice between performance and complexity could be made prior to final lens design.

V. LENS ASSEMBLY

All of the lenses in the system have maximum wavefront aberrations of approximately $\lambda/4$. They have up to 14 air glass surfaces as well as two or more cemented surfaces. The quality of each of these surfaces must be very good so that the accumulations of the errors on the individual surfaces including the inhomogeneity of the glass does not approach the aberration tolerance. The centering and spacing of the elements must be of extraordinary quality to maintain the diffraction limited performance. Conventional techniques for measuring and controlling the centering and spacing of lens elements are not sensitive or accurate enough for lenses of this type. The lenses have been assembled by Tropel using new techniques that they have developed in recent years. We have carried out a program at the Laboratories to explore improved interferometric techniques that will make even better lens systems feasible.

VI. LENS EVALUATION

Lenses are now evaluated by photoelectrically measuring the modulation transfer function in a lens bench. This is done by scanning the image of a periodic target with a slit or the image of one slit with a second one and calculating the transfer function. For lenses of this quality, the slits must be extremely narrow and the measurement is limited by the photon noise of signals through the slits and the stability of the lens bench and air during the time of measurement. One measured curve is shown for the 3.5X lens but the measurement is not convincing as the curve goes above theoretical values at high frequency. Wavefront measuring methods are now being developed from which better MTF curves should be obtained.

* Located in Fairport, New York.

VII. PATTERN GENERATOR LENS

The pattern generator lens has very special requirements. It must both collimate the laser beam before it is reflected from the polygonal mirror and then image the reflected beam to a flat focal plane on the photographic plate. The effective aperture position for the lens is at the surface of the mirror. The gaussian light distribution in the aperture of the lens is controlled by the illuminating laser beam. Although the lens is corrected at $f/10$, the writing beam fills the aperture with an $f/22$ cone angle which gives a 10μ -diameter gaussian distribution in the image. The code beam fills a larger aperture in the scan direction so that a higher modulation is obtained when the image scans the $7\text{-}\mu\text{m}$ bars and spaces of the code beam. The lens must provide a large amount of barrel distortion so that a constant angular rate of the scanning mirror provides a uniform linear scan in the focal plane. The combination of no vignetting of the laser beam in the lens and a uniform linear velocity of the scan gives a uniform exposure over the plate. Figure 2 shows the scanning lens and Fig. 3 shows the calculated MTF of this design.

VIII. REDUCTION-CAMERA LENSES

The reduction-camera lenses image the pattern generator plate onto HRP photographic plates. The mercury 435.8-nm spectral line is used so that only the monochromatic aberrations are critical. The lenses are correct for first-order axial and lateral color at this wavelength. The field angle is a compromise between camera length and aberration correction. The entrance pupil distance is the same for both the 3.5X

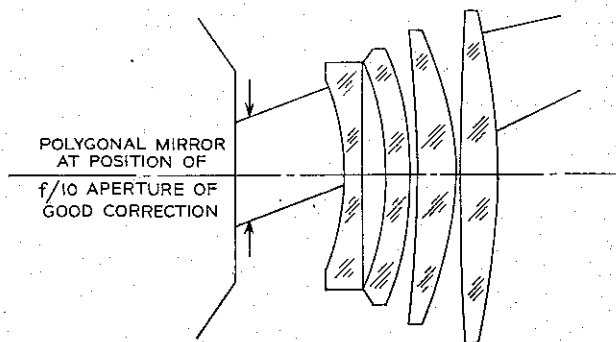

Fig. 2—Cross section of pattern generator lens.

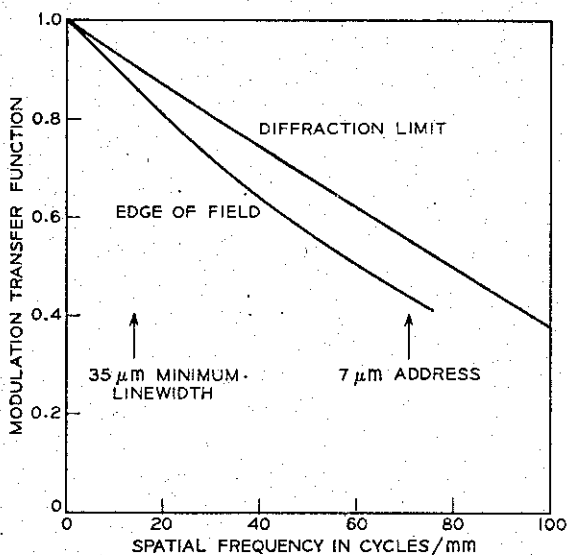

Fig. 3—MTF curves for the pattern generator lens on axis and at the edge of the field in relation to the fundamental frequency of the 7- μm address and 35- μm linewidth.

and 1.4X lenses so that the same illumination system can be used for both. Microflat glass plates are used in this camera so depth of focus is not important. The apertures have been selected to give best image quality and an iris is built into each lens so that they can be stopped down if poorer quality glass is used.

The 435.8-nm wavelength was selected as a compromise between the better resolution at the shorter wavelength than the more commonly used 546.0-nm line, and the smaller amount of scattered light in the green. The scattering in the blue is greatly reduced by using the dyed emulsion plates that are described in another article in this issue.

IX. 3.5X REDUCTION CAMERA LENS

The 3.5X reduction-camera lens shown in Fig. 4 is a seven-element double-Gauss type operating at $f/3.5$ and having a focal length of 17.7 cm. Efforts were made to use an eight-element design for better performance but the improvement was not judged sufficient to exceed the probable losses in an extra element. Figure 5 shows the MTF curves for this lens on axis and at the edge of the field along with the diffraction limit for the lens aperture used. The fundamental frequency

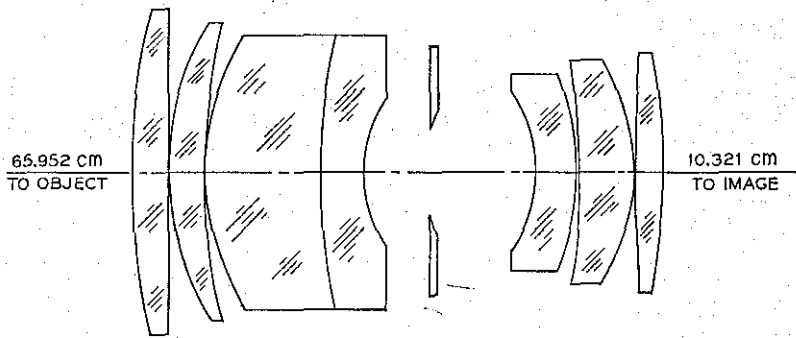

Fig. 4—Cross section of 3.5X reduction camera lens.

for a 10μ minimum linewidth used would be at 50 cycles per mm where the response is 70 percent or greater. There is significant response at a number of harmonics of this frequency to better reproduce sharp edges.

The intensity distribution for a square-wave object can be calculated from the response at the various harmonics in the source. Figure 6 shows the intensity distribution calculated for this lens from a 10μ -periodic square wave object, an isolated 10μ line at the center of

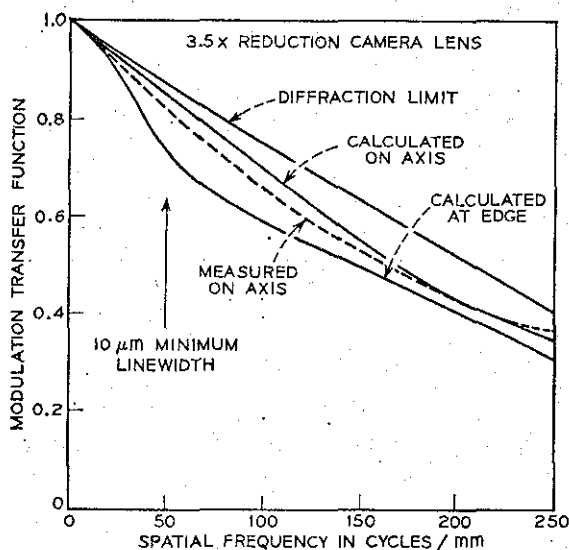

Fig. 5—Measured and calculated MTF curves for 3.5X lens.

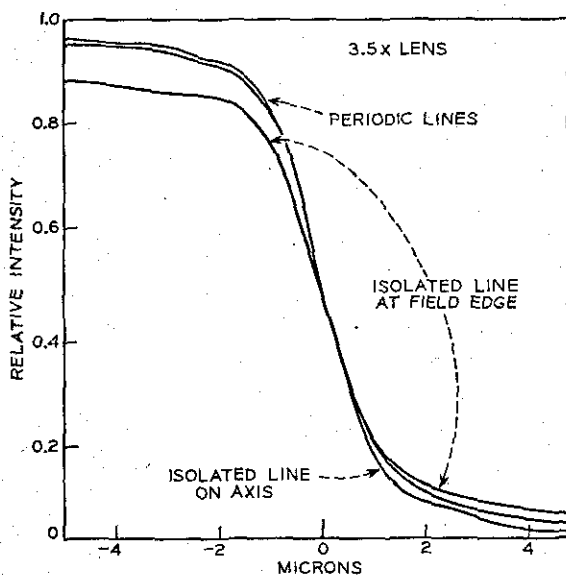

Fig. 6—Intensity distributions for 10- μ m-wide periodic and isolated lines on axis and at the corner of the field of the 3.5X lens.

the field, and at the edge of the field. It is important that the slope of these curves at the edge of the line be large so that variation of exposure caused by light-source fluctuation, photographic-material sensitivity variation, and developing chemistry, time or temperature will not have a large effect on the linewidth developed from the image. As can be seen here, the isolated line and periodic lines would require a

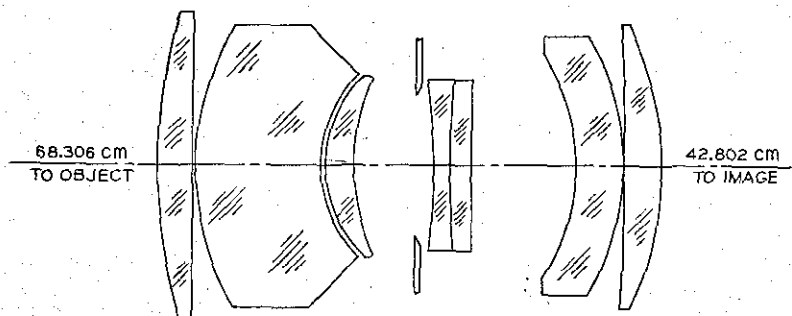

Fig. 7—Cross section of 1.4X reduction-camera lens.

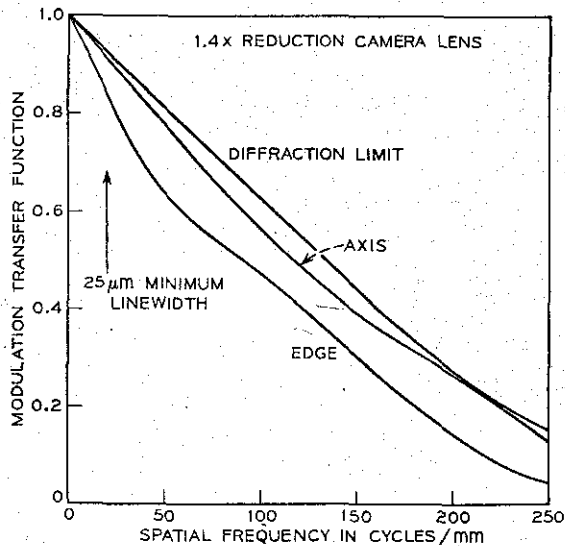

Fig. 8—MTF curves for the 1.4X reduction-camera lens.

slightly different exposure to both have correct linewidth. While this different exposure can be used to obtain accurate linewidth on masks having predominantly isolated or periodic lines, only a lens with a good MTF will give consistently accurate dimensions on all types of features.

X. 1.4X REDUCTION-CAMERA LENS

The outline of the 1.4X lens is shown in Fig. 7. While a double-Gauss type could have been used for this lens, this rather unusual configuration gave better performance for the specific requirement and the size is much smaller than the double-Gauss type.

The focal length is 32.4 cm and the overall length is 128.4 cm. The $f/4.15$ aperture provides a smaller cone to the image than the 3.5X lens but accepts a larger cone of light from the object providing better resolution compared to the finest line.

Figure 8 shows the MTF curves for the 1.4X reduction-camera lens and Fig. 9 shows the corresponding intensity distribution for periodic and isolated 25- μ m lines. The 80 percent MTF at the fundamental frequency of the line results in a sharper line edge in the intensity profile and a resulting larger tolerance in exposure.

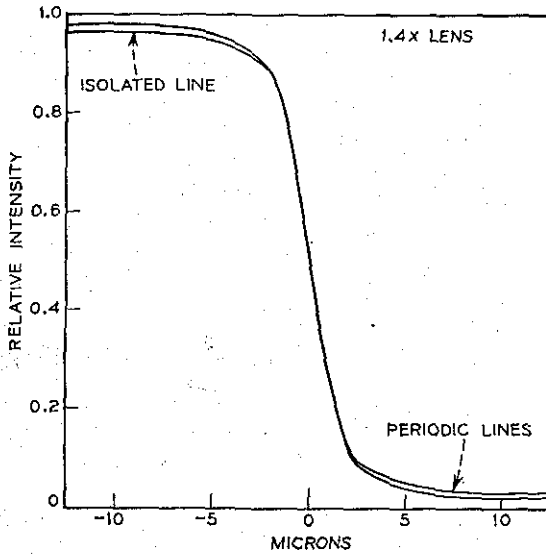

Fig. 9—Intensity distributions for isolated and periodic lines imaged by the 1.4X lens.

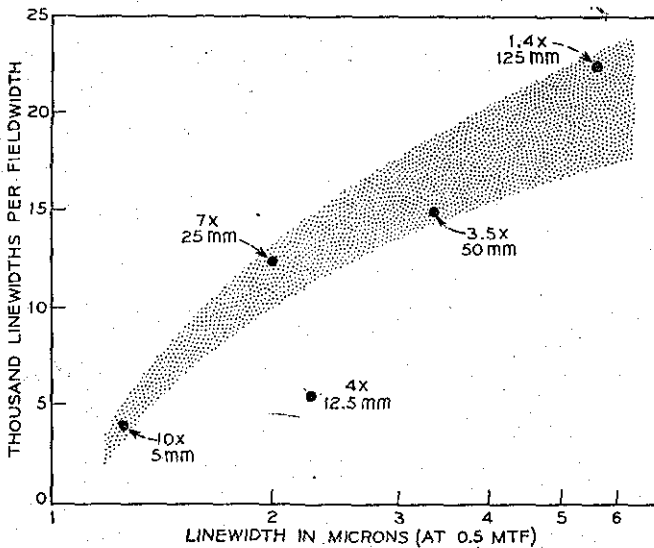

Fig. 10—Performance of a group of photolithographic lenses plotted as the number of linewidths per field width as a function of the linewidth at which 0.5 MTF is obtained.

XI. CAPABILITY OF GENERAL PHOTOLITHOGRAPHIC LENSES

The designs of the lenses in this system, including a 7X reduction-camera lens that has not been used, show the general range of performance that can be obtained. Figure 10 shows the number of thousands of linewidths per field as a function of the linewidth at 0.5 MTF. The shaded region indicates the area of reasonable design. There is not a smooth curve through these points as different lens types are used. A smoother curve could be drawn for each lens type. The 4X projection lens below the shaded area is limited in aperture and therefore resolution because of the required depth of focus. The 10X step-and-repeat lens is a very reliable point as many designers have designed lenses having these parameters. The step-and-repeat lens is described in detail in another paper in this issue.

An Overview of the New Mask-Making System

By F. L. HOWLAND and K. M. POOLE

(Manuscript received July 9, 1970)

This paper reviews how photolithographic masks for silicon and thin-film integrated circuits are made. Increasing production and complexity of masks makes heavy demands on the operating time, reproducibility, and accuracy of the new mask-making system. The pattern generation step, in which the design is converted to a photographic image, is critical to the system. Advantages and disadvantages of other pattern-producing methods are discussed. The technique of producing patterns by optically scanning lines with a rotating mirror while mechanically stepping the photographic plate is described. This article develops the basic design parameters of address structure and operational speed for the primary pattern generator, and it defines the requirements for reduction cameras and the step-and-repeat camera for a system capable of meeting the needs for both thin-film and silicon integrated circuits. The article notes the system limitations imposed by optical generation of patterns and lens tolerances.

I. INTRODUCTION

The Electronic Materials and Components Development Area of Bell Telephone Laboratories has made the development of hybrid-integrated electronics, combining semiconductor and thin-film technologies, its major general field of activity for several years. Silicon integrated circuits provide the active elements for both digital and analog systems, and passive components can be incorporated if tolerances are not too tight. Thin-film circuits based on tantalum can provide stable resistors and capacitors which can be trimmed to precise values, while other thin-metal films can be used advantageously for conductors. Thus silicon and thin-film technologies together provide a sufficient set of elementary components for most systems functions. Equally important, the choice of silicon circuits made in the beam-

leaded, sealed-junction form and thin-film elements on ceramic or similar substrates give us complementary technologies which are physically compatible.

Both parts of this hybrid-device technology have come to depend primarily on photolithographic methods for delineating the areas in which material will be added, removed, or modified as the original substrate is successively transformed into the final circuit. Both parts of this technology have grown in volume of activity and in sophistication of technique. In doing so they have put increasing demands on mask-making laboratories for more masks per year and for more complex mask patterns.

The system described in this issue of *The Bell System Technical Journal* provides for both semiconductor and thin-film integrated circuits using facilities that are coupled by an information system. The mask-making system is designed to have the capability of meeting the demands for larger numbers of increasingly complex masks with a known time interval between the receipt of design information and the delivery of a complete set of masks.

II. HISTORICAL BACKGROUND

All mask-making systems can be described schematically as shown in Fig. 1. Two streams of information, one topographic and the second descriptive, must be provided.

The topographic stream starts with the designer who generates the input information on the topography for each mask level and stores the information using a program such as XYMASK. The information thus generated is not suitable for direct use in making artwork, so a post-processor is used to modify data and make it compatible with a specific artwork-generating system. After the processing and, if necessary, recycling to eliminate errors, the output data can be used to drive the artwork-generating equipment.

After the artwork is generated, a series of photo-reductions are performed and, if required, an array of images is produced using a step-and-repeat camera to produce the master photo mask. From this master, working copies are generated, the specific process depending on the ultimate need. Working copies can be emulsion or chrome on glass for semiconductor circuits, or emulsion on glass or transparent plastic for thin-film applications.

In parallel with the topographic information, descriptive information is also required. The descriptive information includes the tone of

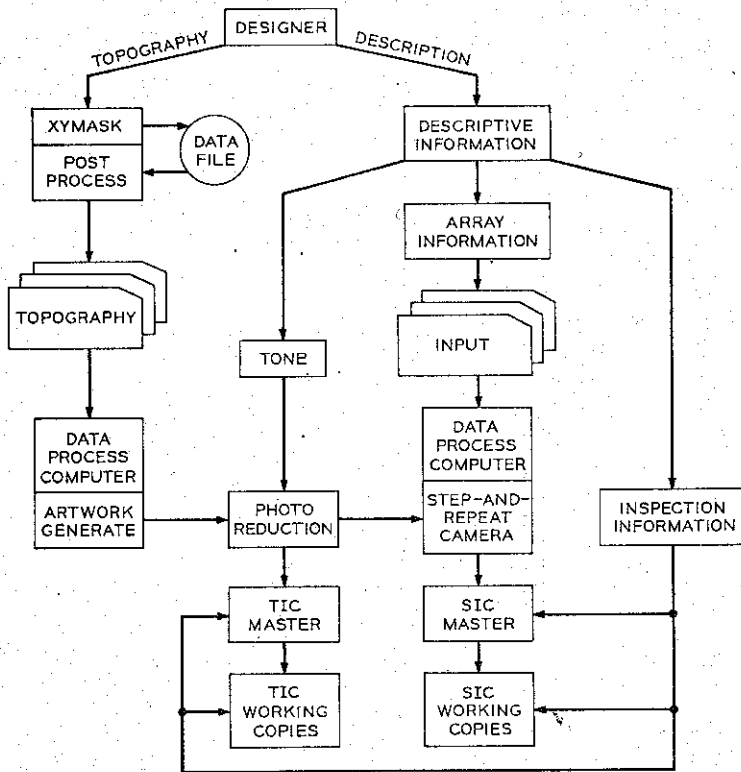

Fig. 1—Schematic of the mask-making process.

the mask; that is, are there clear features on an opaque background or are there opaque features on a clear background? The tone is established by the specific process to be used for delineating the pattern in the final product. For masks requiring the step-and-repeat operation to generate the array, information concerning the specific pattern of images must be defined and the necessary data generated for producing the array. Finally, the descriptive information must include drawing numbers, tolerances, and critical features to be used as inspection points; this information relates to the final inspection of the master and working copies. The descriptive information is as critical in mask making as the topographic information. Because of the combined topographic and descriptive information paths and the complex of processes, management of a mask-making laboratory is a very important part of the system.

As device complexity has increased, with a consequent increase in the amount of data required to describe the topography of an image, computer-controlled artwork generators have been developed. Two distinct types of artwork-generating equipment have evolved. The first are mechanical systems, such as a coordinatograph, the Gerber,* or a mechanical reticle generator which operates by moving a generating head on a mechanical XY stage or moving the recording medium past a fixed optical head. The second type uses an electron beam and camera to generate the artwork.

The mechanical systems which generate the artwork feature-by-feature have a potential address structure that is not fully utilizable because of errors in the mechanical systems. In general, however, they can be operated reproducibly with 6000 addresses in the X and Y directions. Because of the nature of the mechanical motion, the time required to produce a given piece of artwork is sensitive to both the complexity and the size of the feature.

An example of the use of an electron beam and camera system is the SC 4020.† This system is capable of generating a pattern at electronic speeds by moving an electron beam over a cathode ray tube and photographing the image. It produces a mask rapidly but the address structure is limited and, as a consequence, it can only be used for low-precision artwork generation.

After the artwork is generated it is, in general, reduced in size. Typical reduction cameras for both silicon and thin-film circuitry produce images that are reduced by a factor of from 10 to 30 from the original artwork. These cameras are all physically large and require high-quality lenses to minimize distortion. At this step the master mask for thin-film applications is produced. Working copies for device processing are generated by contact printing.

For silicon integrated circuits the image produced by the reduction camera is typically ten times the final size. The final reduction and the fabrication of the circuit array is done on a step-and-repeat camera. Because of the complexity of the array, in terms of the variety of images to be produced, the cameras are computer controlled. For a typical mask the primary interest is, of course, the formation of an array of precisely placed images of the primary pattern that is required for the fabrication of the working device. In addition, however, special patterns such as test patterns for checking processing and alignment features are also

* Gerber Scientific Instruments Company, South Windsor, Connecticut.

† Stromberg Data Graphics, San Diego; California.

required. Since a typical semiconductor integrated circuit requires from nine to twelve mask levels to complete the device fabrication, the step-and-repeat camera must provide not only for the final optical reduction but also for the precisely controlled and reproducible positioning of the images so that registration from one mask to another in the set is achieved. In the past step-and-repeat cameras could place an image with a reproducibility of $\pm 1.5 \mu\text{m}$. However, the errors in the mechanical drive and position-sensing systems made absolute positioning considerably less accurate.

III. MASK-MAKING PRECISION, STANDARDS, AND CAPACITY

With this background of the mask-making process and the then-available equipment to produce the mask, the changing complexity, as measured by the number of coordinates required to describe the image of the masks for both silicon and thin-film circuits, has had a major impact on the capability of mask-making systems to meet the demands. Projection of our future needs for integrated-circuit masks suggested that we will have to provide for: (i) a minimum feature size five thousand times smaller in linear dimension than the over-all size of the circuit pattern; (ii) incremental sizes of about one-fifth of this minimum feature size; (iii) reproducibility of about one part in 25,000; and (iv) absolute accuracy of about one part in 10,000 (both reproducibility and accuracy being referred to the over-all size of the pattern). Examination of the state of the art of lens design suggested that cameras could be built to be consistent with these needs, provided that we adopted a set of standard mask formats and that we designed lenses and cameras for each standard field size and reduction ratio.¹

Such a set of standards has been chosen (Table I). They provide for large thin-film circuits with a nominal field size of 12.5 cm and a smaller format, 5 cm, which both provides for medium-sized thin-

TABLE I—STANDARD MASK SIZES

Principal Function	Field Size	Minimum Line Width	Address Size
Thin-film circuits	12.5 cm	25 μm	5 μm
	5.0 cm	10 μm	2 μm
	2.5 cm	5 μm	1 μm
Semiconductor circuits	5.0 mm	1 μm	0.2 μm

film circuits and serves as an intermediate step in semiconductor-mask fabrication. A third standard may become necessary for small, fine-lined, thin-film masks and appropriate values are listed in Table I. Semiconductor integrated circuits seem likely to remain under 5 mm square, and a single standard field for a step-and-repeat camera is sufficient. This set of standards embodies (i) a decision to "go metric" in device design, (ii) a compromise between design flexibility and the capital cost of equipment, and (iii) a preference that the address units, which quantize internal device dimensions, be such that large integral multiples be immediately identifiable.

In the same period of time in which the growth in the complexity of mask patterns has occurred there has been a parallel increase in the demand for numbers of masks. This growth has been the direct result of a need for larger numbers of masks to fabricate a given device coupled with an increase in the number of designs. To illustrate this growth of demand, information has been collected from a variety of Bell Laboratories groups covering the period from 1966 to the present and estimating the needs for the early 1970s. The results are shown in Fig. 2.

The growth in demand for silicon integrated circuits, SIC, from 1966 through 1969 has been nearly exponential and has been in part inhibited by our inability to produce sufficient quantities of masks. Because of the increased numbers of people designing integrated circuits, the growth will continue to be slightly greater than linear during the early 1970s. Thus, somewhere between 7,500 and 8,000 pieces of artwork per year will be required by 1972 or 1973.

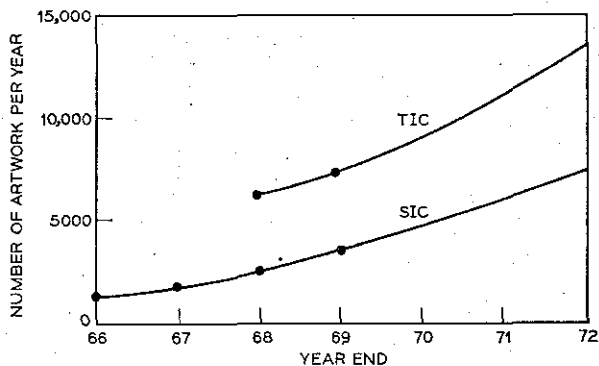

Fig. 2—Growth in demand for artwork for silicon and thin-film integrated circuits.

Because the silicon integrated circuit and thin-film circuits are intimately connected in design, it can be expected that the need for thin-film masks, TIC, will also rise during the early 1970s as shown in Fig. 2. In part, this growth represents the need for increasing numbers of masks for crossovers and tantalum circuits that are combinations of resistors, capacitors, and crossovers.

If we take the composite of these two trends, we find that development activities will require that approximately 14,000 pieces of artwork be generated per year by 1972. To meet this demand, it was decided to build two mask-making laboratories, one at the Murray Hill, New Jersey, location and one at the Allentown, Pennsylvania, location. Each laboratory was to have a master mask capacity of 10,000 per year.

IV. CHOICE OF PATTERN GENERATOR

Pattern generation is a key element in the total process of mask-making in the sense that the difficulty of meeting the many demands placed on this step is so great that the adjacent steps of the process must largely be tailored to the choice of pattern generator. The overall process resulting from each plausible choice of pattern generator design must then be evaluated before a final system choice is made.

The nature of the problem logically requires relative motion in two dimensions between a writing element and a recording medium. The functional requirements which have been discussed in the previous section suggest a digitally controlled plotter having resolution corresponding to 25,000 by 25,000 address points in the pattern field and a plotting time for the more complex patterns of about 10 minutes.

Reviewing the pattern generators which have previously been used, we first have machines such as automatic coordinatographs and automatic drafting machines with optical exposure heads. A machine of this type could be designed to give the desired resolution. The plotting time for complex patterns on such machines has already exceeded ten hours. Another approach is the reticle generator which makes a set of elementary figures available from which every mask will be assembled. We have not found any set of figures which offer sufficient speed and flexibility.

The following three approaches to pattern generation appear to have sufficient resolution, accuracy and speed to meet our requirements: drum recording, electron-beam recording and light deflection. Each is discussed in turn.

4.1 *Drum Recording*

In the drum recorder the recording medium is wrapped around a cylinder as shown in Fig. 3. The two dimensions of motion are now achieved by synchronizing the rotation of the drum and translation of either the drum or writing head parallel to the axis of rotation. If we insist on a system capable of writing on various areas of the recording medium in an arbitrary sequence (random access), this system offers no advantage over a flat-bed plotter; however, it does make it possible to create any pattern by continuous rotation of the drum and a synchronized translation. After unwrapping the recording medium, the image would appear as though it had been created by a TV-like raster. It is this concept of a uniformly swept raster which makes a mechanically scanned system feasible.

This pattern generator could be engineered within a relatively wide range of sizes, tolerances on the precision of the translational mechanism, on the concentricity of the drum, and on the thickness of the recording medium becoming increasingly tight in smaller machine sizes. A 12.5-cm pattern size would be possible, while a 25-cm size unit would be relatively simple to develop. The primary problem in

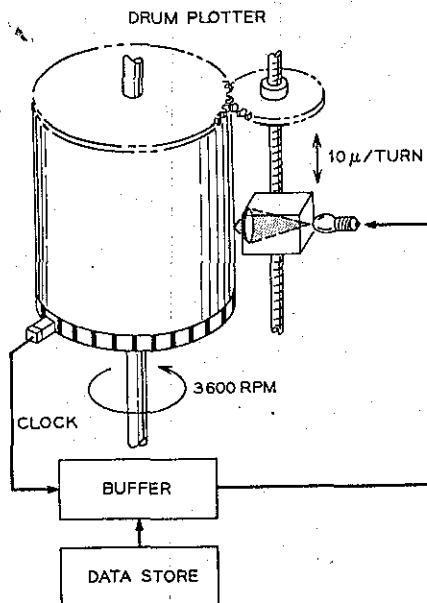

Fig. 3—Schematic of a drum plotter.

this approach is that the recording medium must be flexible. The combination of a silver halide emulsion on a film base does not have sufficient dimensional stability for our purposes. An alternative which was considered was laser machining some appropriate coating from a metal based multi-layer medium. Brief experiments suggested that such a medium would not be easy to handle and, being opaque, would have to be used in front-lighted reduction cameras. Such cameras are inefficient and the drum approach was dropped from further consideration.

4.2 *Electron Beam Recording*

An electron beam machine in which a finely focussed beam writes directly on a recording medium of appropriate resolution and sensitivity is a probable approach to pattern generation. An electron beam recorder can be designed for a beam size of a few microns and a field of several centimeters.² Choice of a 5-cm field allows direct generation of one standard format and allows the other standard sizes to be produced in cameras using glass condenser illumination. Pattern description for this system is a simple extension of previous work for cathode ray tube systems. This technique seems to offer system compatibility; the major uncertainties which existed at the time at which a selection had to be made (November 1967) were whether the desired accuracy could be obtained, and whether the sensitivity of electron beam systems to unwanted electric and magnetic fields would limit its reproducibility. These uncertainties were sufficiently great that this approach was not chosen for our initial system, but development work was continued to provide a compatible system which might be advantageous for future large-area devices such as color and document-mode *Picturephone*[®] camera tubes and magnetic domain devices. This machine is described in a companion paper.²

4.3 *Light Deflection*

Of the three approaches, only deflection of a light beam seemed capable of meeting our anticipated requirements. Since the combination of plotting time and number of resolvable elementary areas in the pattern field requires exposure times of less than one microsecond per resolvable area, the use of a laser beam to achieve a small, very bright writing spot was indicated. Deflection of a laser beam can be accomplished by electro-optic or acousto-optic elements, but available deflector materials were not of sufficient quality to give

plotting times less than one or two hours. Reflection from a spinning mirror, however, can give speeds up to and beyond those required as long as we accept a uniformly rotating mirror as the basis for our system. This led to a rotating-mirror pattern generator design where a modulated light beam would be swept across a photographic plate in one direction at a rate of about 50 scans per second, while the plate holder would move in the direction perpendicular to the scan lines. In less than ten minutes 25,000 overlapping scan lines could build up the complete pattern image. Again, in this system, we have employed continuous rotation of the higher-speed scanning member to achieve the desired plotting rate in a mechanical system. Implementing this approach requires that a lens be mounted adjacent to the rotating mirror, a diverging input beam being collimated by the lens and refocused onto the recording medium after reflection. Because of the inverse relationship between the aperture of a lens and the diameter of the smallest spot which the lens can image and because the field angle for which a lens can be designed is sensitive to the relative aperture size, the lens and mirror sizes enlarge rapidly as the desired pattern size is diminished.³ Specifically, the design appears impracticable at the largest standard pattern size of Table I and relatively easy at a 25-cm pattern size. Thus, the initial pattern size for this machine design is rather firmly bounded by optical-design considerations on the one hand and by considerations of plate size, governing the size of both processing equipment and reduction cameras, on the other. 8 by 10 inch photographic plates are commercially available and, in $\frac{1}{4}$ inch thickness, can be obtained with sufficient flatness. Translating to metric units gives a maximum usable area of about 13.8 cm by 23.4 cm. This puts an upper bound of $7.3 \mu\text{m}$ on the address unit size, and $7.0 \mu\text{m}$ seems a reasonable value. A review of the optical design based on this value led to reasonable sizes for the individual components and for the over-all machine.

Pattern description for the primary pattern generator (PPG) requires that the topographical data be sorted into a sequence controlled by the directions of scan, and presented to the generator at a predetermined rate. These are novel requirements relative to our experience in computer aids to mask-making.⁴ While the sorting operation requires large files in the off-line data-processing system, the operation is not a costly one. A larger problem is created by the need to present data to the generator from its on-line controlled computer at a predetermined rate of about 2 million bits per second. The strategy used to meet this demand is such that most of the core memory is required for storage of coded data describing the current scan line and the changes

required to go from the current line to those immediately following, and thus all characteristics of features, particularly where they include slant and curved edges, have to be computed off-line and coded for transfer by means of a magnetic tape. At this time this is a significant disadvantage in the choice of the PPG as opposed to a random-access generator such as the electron beam machine.

The characteristics of the PPG previously discussed determine the design requirements which it must meet. With reference to Table I, it is evident that for thin-film circuits optical reduction of the image plate from the PPG is required. A reduction camera that reduces the image 1.4 times is required for the bulk of the thin-film circuits that have a minimum line width of 25 μm . A second camera with a 3.5 reduction ratio is also required for 10 micrometer minimum lines on a smaller field. This camera is also used for silicon integrated circuits. A third reduction camera for 5- μm lines may be required in the future if 5-mm lines are required on small areas. Conventional glass condenser systems are not practical for these cameras, and large area diffuse sources with Fresnel lens condenser systems are used to meet our requirements.⁵ The cameras have been designed with no operator adjustments for either reduction ratio or focus.

For silicon integrated circuits the image produced by the 3.5 \times reduction camera is used as the reticle in the step-and-repeat camera which provides an additional 10-times reduction.⁶ The step-and-repeat camera, in addition, generates an array of images—each with a 5-mm maximum field size and a maximum array size of 10 cm by 10 cm.

V. SYSTEM DESIGN

In completing our account of the new mask-making system, we should recognize that not all devices are square. Many thin-film integrated circuits are rectangular. As long as a camera is to be used to image a rectangular pattern, the diagonal measure of the pattern is a dominant consideration. It is not necessary, however, to compound this penalty by fitting a square pattern field within the circular field of the cameras and then constraining a rectangular pattern to lie within the square. Thus the field of the pattern generator was enlarged from 25,000 address units square to 32,000 units (22.4 cm) and, at the same time we enlarged the width to 26,000 units (18.2 cm) since the space was available.

Fiducial marks which provide for registration of patterns in the step-and-repeat camera are plotted in the corners of the 32,000- by 26,000-unit rectangle. In addition, the pattern generator writes two

strips of system data, one above and one below the rectangle. The first strip shows the identification number of the particular pattern generator used and the sequence number in octal form. The second strip contains the drawing number of the pattern in three forms. One is the normal form for the direct use of mask shop operators, but in addition the number is repeated in two binary-coded formats suitable for machine reading. One is designed to be read when the pattern generator plate is in the reduction camera and the other to be imaged by the 5-cm field-reduction camera and read when the resulting reticle is in the step-and-repeat camera.

These provisions for machine reading of the drawing number are part of a supervisory and scheduling system known as the Mask Shop Information System (MSIS).⁷ Earlier experience with mask-making laboratories of more modest capacity than our 10,000 per year objective taught us that the scheduling system can be the factor determining the time to complete a job. The equipment design which has been outlined here and which will be detailed in the following papers can therefore shorten the time to complete a job only if we add a system for storage and rapid retrieval of all the data required to make and inspect the masks and keep the necessary records. Scheduling each phase of each job is included; as each step after pattern generation is due, the MSIS displays to the camera operator the drawing number of the pattern generator plate or reticle and the location of that plate in the physical storage trays provided. The system then reads the plate number and advises the operator if an error has been made. At the step-and-repeat stage, all data describing the step-and-repeat array is fed to the on-line control computer.⁸

VI. SYSTEM APPRAISAL

While we have not yet had sufficient experience with MSIS, nor with a level of demand for masks which would have fully exercised MSIS, we can make a preliminary appraisal of the remainder of the system.

The PPG has accomplished essentially everything we set out to do. For the first time in many years, artwork generation is no longer the pacing item in mask making; we have a machine which takes simple patterns or patterns of a complexity we would not previously have attempted, makes patterns in which 10 percent of the area is exposed or patterns in which 90 percent is exposed, semiconductor device patterns, thin-film patterns, test patterns—and even digitized photographs—and turns them out with inhuman regularity. While the optical-design pattern bound us into a very narrow size range, the

resulting machine is the right size for the operator's convenience. This is not to say that there is no room for further improvement in the area of artwork generation. We see future device applications in which the higher resolution offered by an electron beam machine could be of major importance, sufficient to justify incorporating such a unit—compatible with the PPG system standards in format and plate size—into the mask-making laboratories.

Turning to the reduction cameras, we feel that the basic system decisions which were made—separate fixed cameras using Fresnel condenser illumination with monochromatic light—were sound. We do believe that further improvements in system performance might be obtained through achieving closer tolerances in lens fabrication; essentially the state of the art of lens design has run ahead of lens assembly techniques. This comment applies even more strongly to lenses, such as the one for the step-and-repeat camera, which are aimed at feature sizes of a few wavelengths of light. The step-and-repeat camera lens proved extremely difficult to build, and appears to have distortion of about one part in 5,000 arising from fabrication tolerances; we would argue that paper designs of lenses of higher performance—perhaps seeking comparable resolutions over a larger field—should be held suspect until actual models are built and tested.

The new step-and-repeat camera is a development of a different kind from most of the other parts of this program. No single characteristic of this unit shows an order of magnitude improvement over earlier equipment, nor does it contain conceptually new major elements. The improvements which have been made, factors of two or three in smallest feature width, in linear field dimensions, in linear array dimensions, and in speed, are cumulative in their impact and are essential to the satisfaction of our anticipated needs.

REFERENCES

1. Herriot, D. R., "Lenses for the Photolithographic System," B.S.T.J., this issue, pp. 2105-2116.
2. Samaroo, W., Raamot, J., Parry, P., and Robertson, G., "The Electron Beam Pattern Generator," B.S.T.J., this issue, pp. 2077-2094.
3. Cowan, M. J., Herriott, D. R., Johnson, A. M., and Zacharias, A., "The Primary Pattern Generator, Part I—Optical Design," B.S.T.J., this issue, pp. 2033-2041.
4. Gross, A. G., Raamot, J., and Watkins, Mrs. S. B., "Computer Systems for Pattern Generator Control," B.S.T.J., this issue, pp. 2011-2029.
5. Poulsen, M. E., and Stafford, J. W., "Reduction Cameras: Mechanical Design of the 3.5 \times and 1.4 \times Reduction Cameras," B.S.T.J., this issue, pp. 2129-2143.
6. Alles, D. S., et al., "The Step-and-Repeat Camera," B.S.T.J., this issue, pp. 2145-2178.
7. Brinsfield, Mrs. J. G., and Pardee, S., "The Mask Shop Information System," B.S.T.J., this issue, pp. 2203-2220.