

United States District Court,  
D. Delaware.

**GENZYME CORPORATION, Genzyme Surgical Products Corporation, Donald P. Elliott, Lynn Halseth, Nicholas F. D'Antonio, and Nicholas J. D'Antonio,**  
Plaintiffs.

v.

**ATRIUM MEDICAL CORPORATION,**  
Defendant.

No. CIV.A.00-958-RRM(GMS)

**July 19, 2002.**

Suit was brought alleging infringement of five patents that related to chest drainage devices. In construing various patent claims, the District Court, Thyng, United States Magistrate Judge, held that: (1) terms "one-way valve means" and "one-way valve" meant a type of valve, also known as a check valve, that allowed the flow of fluid in one direction but prevented flow in the reverse direction; (2) term "flow path" meant a path along which air flowed between the distinct points; (3) claimed function of "dividing means" was to divide first chamber from second chamber, and corresponding structure of "dividing means" was a divider or a partition with an opening, and structural equivalents; and (4) function of the biasing meant to be moving the closing means to a closed or predetermined position, and the corresponding structure disclosed in patent that performed that function was a spring.

Claims construed.

Court-Filed Expert Resumes

4,544,370, 4,715,856, 4,747,844, 4,822,346, 4,889,531. Cited.

William J. Wade, Richards, Layton & Finger, Wilmington, Delaware. Of Counsel: Liam O'Grady, Robert L. Burns, and John Williamson, Finnigan, Henderson, Farabow, Garrett & Dunner, L.L.P.; Attorneys for Genzyme Corporation, et al.

Josy W. Ingersoll and John W. Shaw, Young, Conaway, Stargatt & Taylor, LLP, Wilmington, Delaware. Of Counsel: William F. Lee, Merriann M. Panarella, Wayne L. Stoner, David Cavanaugh, and Dominic E. Massa, Hale and Dorr, LLP, Boston, Massachusetts; Attorneys for Atrium Medical Corporation.

## **MEMORANDUM OPINION**

**THYNGE, United States Magistrate Judge.**

Plaintiffs Genzyme Corporation, Genzyme Surgical Products Corporation, Donald P. Elliot, Lynn Halseth, Nicholas F. D'Antonio, and Nicholas J. D'Antonio (collectively, "Genzyme") filed this patent infringement suit against defendant Atrium Medical Corporation on November 14, 2000. Genzyme alleges that Atrium's "Oasis" and "Express" chest drainage devices infringe certain claims of five of its patents that relate to chest

drainage devices. The five Genzyme patents-in-suit are U.S. Patent Nos. 4,889,531 (the '531 patent); 4,544,370 (the '370 patent); 4,715,856 (the '856 patent); 4,747, 844 (the '844 patent); and 4,822,346 (the '346 patent). FN1 At times, in this opinion, the court will refer to the '531 patent as "the D'Antonio patent" and to the latter four patents collectively as "the Elliot patents."

FN1. Plaintiffs are asserting 26 claims of the five patents-in-suit: (i) claims 1, 16, 17, and 18 of the '531 D'Antonio patent; (ii) claims 1 and 6 of the '370 patent; (iii) claims 2, 3, and 4 of the '856 patent; (iv) claims 5, 6, 12, 13, 15, 16, and 21 of the '884 patent; and (v) claims 5 and 11 of the '346 patent. As certain of these asserted claims depend from other claims, certain claims that the above claims depend from are also at issue.

Presently before the court are the parties' briefs in support of their positions as to the proper construction of the asserted claims of the patents-in-suit. This memorandum opinion is the court's decision as to claim construction. The court will begin by briefly reviewing the technology and patents at issue. This background is drawn from the patents-in-suit and from the parties' presentations during the May 16, 2002 claim construction hearing.

## **I. Background of the Technology**

The patents-in-suit relate generally to "chest drainage devices," devices which are used to remove unwanted fluids, such as blood and air, from a patient's chest cavity. Such fluids may enter the chest during surgery or as a result of trauma. A chest drainage device, in its simplest form, is a bottle attached to a tube inserted into a patient's chest cavity for the collection of fluids that are drained from that cavity.

### **A. Overview: The Elliot Patents**

According to Genzyme, Deknatel, Inc., its predecessor company, introduced the first commercially successful group of chest drainage devices in 1967. FN2 These early devices, called Pleur-Evacs, drained fluids and air from a patient's chest cavity through the use of vacuum suction. In such devices, one tube is connected from the device to the patient, while another tube is connected from the device to a source of suction. Body fluids are then drained through the patient tube and into a collection chamber within the device.

FN2. Prior to the 1960's, even earlier chest drainage devices simply were comprised of a series of glass bottles. As further explained below, the improvements in the late 1960's led to self-contained devices that employed suction and seals that were water based.

An important requirement of any chest drainage device is to prevent the reverse flow of air back into the patient while it is removing air from the chest cavity. It is critical to avoid air flow entering back into the patient, which can be caused when the patient takes a deep breath of air, because reverse air flow can jeopardize the patient's breathing and create a risk of contamination.

The Pleur-Evacs prior art chest drainage devices discussed above used water-based safety features to prevent the reverse flow of fluids through the drainage device. More specifically, for this purpose, the prior art devices employ a "water seal," a column of water that allows the forward flow of air in one direction towards the source of suction, while preventing the reverse flow of air back into the patient's chest cavity. There are, however, several drawbacks to these "water seal" based devices. First, in order for the water seal to work effectively, water must be introduced into the device and be maintained at specific levels. Without priming the water levels before and during use, evaporation lowers the water levels within the device and thus changes the pressures at which the "fail safe" features are designed to function. This requires significant

set-up time and maintenance. A second limitation is that if the device is moved, jostled, or accidentally knocked over, the resulting water spillage will cause the device to stop working, putting the patient in jeopardy.

To solve these problems caused by the use of water as a seal, the Elliot patents disclose a "waterless" (or "dry") chest drainage device that eliminates the water seals used in traditional chest drainage devices and replaces them with a mechanical "one-way valve." The one way valve, like the water seal that it replaces, permits vacuum pressure to evacuate air and fluid from the patient, while preventing reverse flow. This allows for accurate pressure regulation and reverse flow protection without the need for maintaining water levels. In addition to this innovation, the Elliot patents also claim additional design improvements, including a number of pressure relief and control valves and a diagnostic air leak indicator.

The '844 and '346 patents, which are related continuations in part, share the same specification, but have claims of differing scope. According to the specification of the patents, the invention replaces prior art water seals with a fluidless valve mechanism that provides foolproof reverse flow protection. The disclosed apparatus has multiple valves that assist in regulating pressure in the system. The valves include a check valve, a positive pressure relief valve, a control valve, and a negative pressure relief valve.

The check valve, when connected to receive air from the exhaust port of the bottle, effectively prevents back flow into the system. The type of check valve shown in the patent figures is a "flapper-type" check valve that opens in response to a relatively low pressure differential. The positive pressure valve is provided to vent any positive pressure above a predetermined value to the atmosphere, in the event that a positive pressure blows out the check valve. Similarly, a negative pressure valve, disclosed as a "popper-type" valve, is provided to respond to high negative pressures in the device by opening to admit air from the atmosphere. A control valve, disclosed as a "screw-type" valve, operates to control the pressure within the air chamber.

The apparatus described in the specification also includes a diagnostic indicator, which is depicted in Fig. 1 of the '844 patent as transparent U-tube 62. Air removed from the patient passes through the U-tube. The U-tube, when filled with fluid, serves as an air leak detector, as well as an indicator of the inhalations and exhalations of the patient. The court has reproduced the portion of Figure 1 that shows U-tube 62 below.

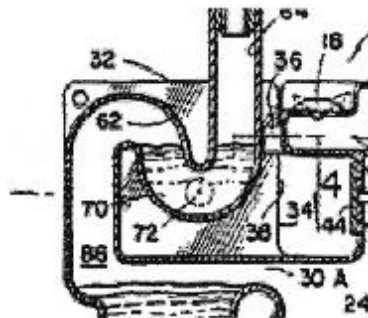

The '370 and '856 patents, which are also continuations in part that share the same specification, constitute improvements on the invention of the '844 and '346 patents. The specifications of these patents include all of the elements of that invention, but also include an intermediate diagnostic tool-U-tube 62a-that holds sterile water to detect leaks and patient breathing characteristics. The inventors, Dr. Elliot and Dr. Halseth, discovered that moving the U-tube to a downstream location provided an improved diagnostic tool that reduced the phenomenon of fluid collecting in the U-tube and backing up the patient tube.

Thus, in the normal operation of claimed chest drainage device air and fluids are evacuated from the patient's chest cavity through a drainage tube. The air passes through the U-tube air leak indicator, which is placed either near the inlet of the device or near the outlet of the device. The air then follows the flow path through the device into the open space above the collection chambers. The air flows through a mechanical one-way valve and exits the device through the air chamber. When the U-tube is filled with fluid, air leaks from the lungs can be observed as air bubbles flowing through the tube.

## **B. Overview: The D'Antonio Patent**

Another important element of a chest drainage device is its ability to regulate the level of pressure within its system that is applied to the patient. The application of too much suction will harm the patient, while the application of too little suction will not provide the desired drainage of harmful fluids from the cavity.

The prior art devices, which employed water-seals to perform the function of a one way valve, also relied upon water-based designs to regulate the level of suction applied to the patient. Specifically, these devices used "water manometer" styled suction controls-water-filled U-shaped tubes-that would allow atmospheric air into the chest drainage device to regulate pressures. By varying the water level, doctors and nurses could vary the level of suction pressure applied to the patient. However, any loss of water, either through evaporation or accidental jostling of the device, placed the patient at risk by the loss of suction control.

The D'Antonio patent, which is entitled "Dry Bottle Drainage System," discloses an improved chest drainage device in which the water-based suction regulation system is replaced with a mechanical "dry" suction regulator. FN3 Instead of employing a water-based control mechanism, the chest drainage device disclosed in the D'Antonio patent utilizes the selective leakage of atmospheric air to regulate the pressure in the suction chamber by controlling a set of mechanical valves. The mechanical regulator can be set at a particular pressure level and will self-adjust to maintain that pressure level.

FN3. According to Genzyme, the dry regulator of the '531 patent was incorporated into Deknatel's A-6000 chest drainage device.

Specifically, the D'Antonio patent specification discloses a wound drainage system that includes an inlet port, a collection chamber, a suction chamber, a suction port, and a suction regulator. The collection chamber collects fluids, both liquid and air, that are withdrawn from a patient. A tube connected to the inlet port connects the collection chamber to the patient. The suction chamber provides a regulated suction to the fluid collection chamber. Whenever the pressure in the collection chamber exceeds that of the suction chamber, air evacuated from the patient flows through the collection chamber and into the suction chamber.

According to the patent specification, an object of the invention is to regulate the pressure of the suction chamber relative to the atmosphere by an economical and effective device. This is achieved by applying a vacuum to the suction chamber and selectively bleeding atmospheric air into the chamber.

The pressure in the suction chamber is regulated by a suction regulator, which has adjoining compartments. A divider or partition divides the regulator into an upper chamber and a lower chamber, and includes an opening for selectively permitting flow between the chambers. The regulator also includes a closing member biased to a position for closing the opening with force according to the desired suction in the chamber. The patent illustrates the closing member in the form of a ball, but states that other gas port closing means such as hinged doors could be employed to regulate pressure in accordance with the disclosed invention.

The regulator allows a medical attendant to select the regulated pressure to be applied to the suction

chamber by turning control knobs that actuates a spring, which is attached to and opens the closing member. When the closing member moves away from the closed position, atmospheric air flows from the first chamber to the second, and into the suction chamber. This selective leakage of atmospheric air regulates the pressure in the suction chamber.

The disclosed device also includes a damping device for damping the resulting force on the closing member, and thereby modulating its movement. The damping device that is disclosed in the patent figures is a dash pot, that includes a piston attached to the closing member ball and a cylinder that receives the piston in sliding engagement.

The following diagram, Figure 1 of the D'Antonio patent illustrates the claimed invention. The claimed mechanical suction regulator, described in detail above, is on the far left of the device:

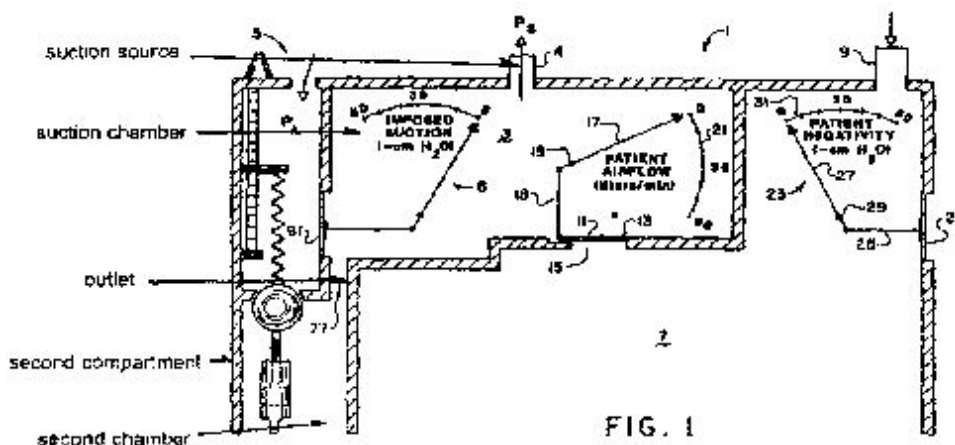

### C. The Accused Products

While the court may not and will not construe the claim terms by reference to the accused products, a brief description of the Atrium products that Genzyme contends infringe the Elliot and D'Antonio patents is helpful to understand and to give some context to the parties' claim construction disputes.FN4

FN4. This limited description is included only to provide background. As the structure of the accused devices is not at issue in the claim construction briefing and only limited aspects of it are discussed in Atrium's summary judgment briefing, the court provides only a few details that it gleaned from that briefing and the parties' presentations.

The accused Oasis and Express devices both contain a collection chamber, a suction chamber, a suction regulator, and a single outlet for connection between the suction chamber and the suction source. The suction regulator that both devices employ is a "dry" mechanical suction regulator. It contains a flat movable valve plug that presses against or covers a valve seat, to prevent atmospheric air from entering the chamber of the regulator that is at suction pressure and flowing through an opening that communicates with the suction chamber. The accused devices also contain a single connection from the device to a source of suction.

The newer Express device also employs a mechanical valve as a seal. (i.e., the Express device is a "dry-dry"

device FN5-using a dry (mechanical) seal and a dry (mechanical) suction regulator).

FN5. Atrium's later-developed Express device competes with Genzyme's Sahara line of "dry-dry" chest drainage devices.

## II. The Law of Patent Claim Construction

### A. Guiding Principles of Claim Construction

[1] [2] The interpretation of patent claim terms is an issue that lies exclusively within the province of the Court. *Markman v. Westview Instruments, Inc.*, 52 F.3d 967, 979 (Fed.Cir.1995) ( *en banc* ), *aff'd*, 517 U.S. 370, 372, 116 S.Ct. 1384, 134 L.Ed.2d 577 (1996). "[I]n interpreting an asserted claim, the court should look first to the intrinsic evidence of record, i.e., the patent itself, including the claims, the specification and, if in evidence, the prosecution history." *Vitronics Corp. v. Conceptronic, Inc.*, 90 F.3d 1576, 1582 (Fed.Cir.1996). The supremacy of the claims, specification, and prosecution history in the interpretation of a patent arises from the public notice function of the patent, a record upon which the public is entitled to rely. *See Markman*, 52 F.3d at 978-79; *Vitronics*, 90 F.3d at 1583.

[3] Claim construction begins with the language of the claims themselves. *See Johnson Worldwide Assoc., Inc. v. Zebco Corp.*, 175 F.3d 985, 989 (Fed.Cir.1999); *see also Digital Biometrics, Inc. v. Identix, Inc.*, 149 F.3d 1335, 1344 (Fed.Cir.1998) (stating that "[t]he actual words of the claim are the controlling focus"). The words of the claims are generally given their ordinary meaning, unless it is apparent from the patent specification or prosecution history that the inventor used the term with a different meaning. *CCS Fitness, Inc. v. Brunswick Corp.*, 288 F.3d 1359, (Fed.Cir.2002) (noting that courts generally "indulge a 'heavy presumption' that a claim term carries its ordinary and customary meaning"); *see also Vitronics*, 90 F.3d at 1582; *Johnson Worldwide*, 175 F.3d at 989.

[4] After looking to the words of the claims, a court must next review the patent specification. Claims are not interpreted in a vacuum, but "must be read in light of the specification, of which they are part." *Markman*, 52 F.3d at 979-80. Indeed, it has been said that the specification "is the single best guide to the meaning of a disputed term." *Vitronics*, 90 F.3d at 1582. The specification may assist the court in the interpretation of a claim term "when it expressly defines terms used in the claims or when it defines terms by implication." *Id.*

[5] [6] In addition, the specification may limit the scope that a patent claim is accorded in circumstances where no broader scope of the claim is described or enabled by the embodiments disclosed therein. *See, e.g., Kraft Foods, Inc. v. Int'l Trading Co.*, 203 F.3d 1362, 1367-69 (Fed.Cir.2000) (limiting "back panel" to the "rigid" back panel described in every embodiment in the specification and excluding the "flexible back panel of the accused device"); *Wang Labs., Inc. v. America Online, Inc.*, 197 F.3d 1377, 1382-82 (Fed.Cir.1999) (limiting "frame" to "character-based" data frames and excluding the "bitmapped" data frames of the accused device, where specification described only "character-based" frames and the prosecution history distinguished the claims from prior art "bit-mapped" frames); *cf. SciMed Life Sys., Inc. v. Advanced Cardiovascular Sys., Inc.*, 242 F.3d 1337, 1344 (Fed.Cir.2001) (holding that "[w]here the specification makes clear that the invention does not include a particular feature, that feature is deemed to be outside the reach of the claims of the patent, even though the language of the claims, read without reference to the specification, might be considered broad enough to encompass the feature in question."). A court should not, however, import a limitation from the specification into the claims, thereby "adding an extraneous limitation appearing in the specification" to the patent claims. *Intervet America, Inc. v. Kee-Vet Labs., Inc.*, 887 F.2d 1050, 1053 (Fed.Cir.1989).

[7] The final category of intrinsic evidence that must be considered by the court is the prosecution history, which contains the record of proceedings between the inventor and the Patent and Trademark Office. *See Vitronics*, 90 F.3d at 1583. Where the inventor disclaims certain claim coverage to distinguish a prior art reference, "the prosecution history limits the interpretation of claim terms so as to exclude any interpretation that was disclaimed during prosecution." *Southwall Techs., Inc. v. Cardinal IG Co.*, 54 F.3d 1570, 1576 (Fed.Cir.1995); *see also Ballard Medical Prods. v. Allegiance Healthcare Corp.*, 268 F.3d 1352, 1359 (Fed.Cir.2001) ("[a]n inventor may use the specification and prosecution history to define what his invention is and what it is not—particularly when distinguishing the invention over prior art.").

[8] [9] If the intrinsic evidence of record is insufficient to resolve ambiguity in a disputed claim term, the court may then resort to extrinsic evidence, such as expert testimony, inventor testimony, or prior art. *Vitronics*, 90 F.3d at 1583. The court may also consider "trustworthy" extrinsic evidence such as dictionaries or technical treatises, even when the patent itself is clear, to ensure that its claim construction is not inconsistent with "clearly expressed, plainly apposite, and widely held understandings in the pertinent technical field." *Pitney Bowes, Inc. v. Hewlett-Packard Co.*, 182 F.3d 1298, 1309 (Fed.Cir.1999). Courts, however, may not rely on extrinsic evidence to contradict or vary the meaning of claim terms made clear by the intrinsic evidence of record. *Vitronics*, 90 F.3d at 1583-84.

## **B. Construction of Means-Plus-Function Claim Limitations**

[10] [11] A number of the asserted claims of the patents-in-suit include limitations drafted in "means-plus-function" form, where the limitation does not describe a specific structure, but instead describes a function and claims a "means" for accomplishing that function. Pursuant to 35 U.S.C. s. 112, para. 6, limitations drafted in means-plus-function form are construed to "cover the [functionally] corresponding structure, material, or act described in the specification and equivalents thereof." *Odetics, Inc. v. Storage Tech. Corp.*, 185 F.3d 1259, 1266-67 (Fed.Cir.1999). Section 112, para. 6 provides a compromise to patentees: patentees may express a limitation in their patent claims "as a means or a step for performing a specified function without the recital or structure ... in support thereof;" such a claim, however, will not be interpreted to cover all structures ... which would perform that function, but only "the corresponding structure ... described in the specification and equivalents thereof." 35 U.S.C. s. 112, para. 6; *see also J & M Corp. v. Harley-Davidson, Inc.*, 269 F.3d 1360, 1367 (Fed.Cir.2001) ("the scope of such [means plus function] claim language is sharply limited to the structure disclosed in the specification and its equivalents"). The duty to link or associate structure to a claimed function is the quid pro quo for the convenience of employing the means-plus-function claiming technique of s. 112, para. 6. *B. Braun Medical Inc. v. Abbott Labs.*, 124 F.3d 1419, 1424 (Fed.Cir.1997).

[12] Determining whether a given claim limitation is subject to s. 112, para. 6 is a question of law. *See Kemco Sales, Inc. v. Control Papers Co.*, 208 F.3d 1352, 1361 (Fed.Cir.2000). Through a series of cases, the Federal Circuit has established a framework for determining when s. 112, para. 6 applies to a claim limitation. *Micro Chem. Inc. v. Great Plains Chem. Co.*, 194 F.3d 1250 (Fed.Cir.1999).

[13] [14] First, if the word "means" appears in a claim limitation in combination with a function, s. 112, para. 6 is presumed to apply. *See Micro Chem., Inc. v. Great Plains Chem. Co.*, 194 F.3d 1250, 1257 (Fed.Cir.1999); *York Prods., Inc. v. Cent. Tractor Farm & Family Ctr.*, 99 F.3d 1568, 1574 (Fed.Cir.1996). This presumption arises because "the use of the term 'means' has come to be so closely associated with 'means-plus-function' claiming that it is fair to say that the use of the term 'means' ... generally invokes section 112(6)." *Greenberg v. Ethicon Endo-Surgery, Inc.*, 91 F.3d 1580, 1583 (Fed.Cir.1996). Additionally, if a claim recites "means" language, but does not include sufficient structure to perform the function, it is interpreted as a means-plus-function claim under s. 112, para. 6. *See, e.g., Wegner Mfg. Inc. v. Coating Mach. Sys., Inc.*, 239 F.3d 1225, 1232 (Fed.Cir.2001) (holding that "air circulation means" was subject to s. 112, para. 6, because it recited the function of "circulating through said reel," without reciting any structure

for performing that function).

[15] Second, the presumption that s. 112, para. 6 applies to claim terms using the term "means" may be overcome—and the claim term should not be construed as a means-plus-function limitation—if the claim contains a sufficiently detailed recitations of structure, material, or acts to perform the claimed function. *See Personalized Media Comms. v. Int'l Trade Comm.*, 161 F.3d 696, 704 (Fed.Cir.1998); *see also Sage Prods. v. Devon Indus., Inc.*, 126 F.3d 1420, 1427-28 (Fed.Cir.1997) ("[W]here a claim recites a function, but then goes on to elaborate sufficient structure, material, or acts within the claim itself to perform entirely the recited function, the claim is not in the means-plus-function format" even if the claim uses the terms "means"); *but see Laitram Corp. v. Rexnord, Inc.*, 939 F.2d 1533, 1535 (Fed.Cir.1991) (holding that structural description that served merely to further specify the function of the recited means did not take the claims outside the scope of s. 112, para. 6).

[16] Third, the presumption that s. 112, para. 6 applies to a claim limitation using the term "means" may also be overcome if the limitation does not link the "means" to a function. *See York*, 99 F.3d at 1574 (holding that claim with a "detailed recitation of structure" but no connection to any function was not subject to s. 112, para. 6); *see also Rodime PLC v. Seagate Tech., Inc.*, 174 F.3d 1294, 1303 (Fed.Cir.1999) (holding "positioning means" was not subject to s. 112, para. 6 where the claim recited a detailed list of structural elements). If no function is linked to the "means" in a claim limitation, that claim limitation cannot be a means-plus-function limitation. *York*, 99 F.3d at 1574.

[17] Finally, if a claim element does not use the word "means," it is presumed to fall outside s. 112, para. 6. *Micro Chem., Inc.*, 194 F.3d at 1257. Such claim limitations, however, may still be subject to s. 112, para. 6, even if the limitation does not use the word "means," where the limitation is written in functional terms and does not recite sufficient structure to describe the performance of that claimed function. *See, e.g., Id.*; *Mas-Hamilton Group v. LaGard, Inc.*, 156 F.3d 1206, 1213-15 (Fed.Cir.1998) (holding that "lever moving element" and "movable link member" were means-plus-function limitations, even though the term "means" was not used in claims, because the limitations did not recite definite structure and did not give generally understood structural meanings in the art).

[18] Once the court has determined that a claim element is subject to s. 112, para. 6, the court must first identify the claimed function, and, second, determine the corresponding structure disclosed in the specification. *See IMS Tech., Inc. v. Haas Automation, Inc.*, 206 F.3d 1422, 1430 (Fed.Cir.2000); *Micro Chem.*, 194 F.3d at 1258. To determine the appropriate structure, the court should look not only to the specification, but to the prosecution history, as patentees will be estopped from asserting an interpretation of a means-plus-function claim that would be broad enough to cover a prior art reference that the patentee disclaimed coverage of during prosecution. *Alpex Computer Corp. v. Nintendo Co. Ltd.*, 102 F.3d 1214, 1221 (Fed.Cir.1996) ("positions taken before the PTO may bar an inconsistent position on claim construction under s. 112, para. 6"); *see also Ballard*, 268 F.3d at 1361.

### **III. Claim Construction of the Elliot Patents**

#### **A. The Parties' Positions**

Before launching into a legal discussion that necessarily includes a detailed review of the claims, specifications, and relevant portions of the prosecution histories of the patents-in-suit, the court will briefly attempt to summarize the parties' positions regarding the proper claim construction of the disputed claim terms. This will give some context to the sections that follow.

#### **1. Disputed Claim Terms**

The parties dispute the following claim terms in the Elliot patents.



-> "waterseal" and "underwater seals"-as used in Elliot '844, claims 5 and 6, Elliot '346, claims 5 and 11, and Elliot '370, claims 1 and 6.

-> "one-way waterless valve means" and "one way valve seal"-as used in Elliot '844, claims 5, 6, 12, 13, 15, 16, and 21, Elliot '346, claims 5 and 11, Elliot '370 claims 1 and 6.

-> "means defining a flow path"-as used in Elliot '844, claims 5, 6, and 21, Elliot '346, claims 5 and 11.

-> (i) "U-shaped fluid path," (ii) "air-leak indicator means," (iii) "transparent U-tube," and (iv) "combination negative pressure indicator and air leak detector assembly"-as used, respectively in (i) Elliot '844, claims 5 and 6; (ii) Elliot '844, claim 21, and Elliot '346 claims 5 and 11; (iii) Elliot '370, claims 1 and 6; and (iv) Elliot '856, claims 2, 3, and 4.

## **2. Genzyme's Position on Disputed Terms of the Elliot Patents**

Genzyme submits that a "one way valve" refers to a type of valve, also known as a check valve, that allows the flow of fluid in one direction but prevents the flow in the reverse direction. It ascribes the same meaning to the term "one-way valve means." Genzyme also asserts that a "waterless valve" is a valve in which water or fluid is not used to serve as a valve. Last, Genzyme contends that both the term "flow path" and the phrase "means defining a flow path" refer to a path along which air flows between specific points.

## **3. Atrium's Position on Disputed Terms of the Elliot Patents**

According to Atrium, the inventors of Elliot patents did not invent the broad concept of using a one-way waterless valve. Based on the patents' specifications and prosecution histories, it is Atrium's position that the scope of the patent should be narrowly limited to the specific structures disclosed.

Hence, Atrium urges the court to construe the terms "one-way waterless valve means" and "one-way valve seal" to mean the disclosed high precision flapper-type check valve, which performs the functions of permitting flow out of the air space and of preventing reverse flow back into the collection chamber. Atrium also argues that the term "means defining a flow path" means the disclosed relatively open and straight space above the fluid collection chambers which performs the function of defining a path for fluids to flow from the inlet to the one-way valve.

As for the terms "waterseal" and "underwater seals," while Genzyme did not take a position on the claim terms "waterseal" or "underwater seals" in its opening brief, Atrium asserts that these terms both mean a fluid-filled structure that allows air to escape from the patient and prevents back flow of air to the patient under certain circumstances, but which allows back flow to relieve high negative pressure. Additionally, Atrium contends that the terms "U-shaped fluid path," "air leak indicator means," "transparent U-tube," and "combination negative pressure indicator and air leak detector assembly" all mean an air leak detector or U-tube that is not a water seal.

## **B. The Court's Claim Construction of the Elliot Patents' Terms**

### **1. "one-way valve" and "one-way ... valve means"**

[19] The terms "one way valve" and "one way ... valve means" are used in a number of the asserted claims in the Elliot patents-in-suit. Claim 1 of the '856 patent, for example, discloses a "one-way valve" seal downstream of the negative pressure indicator and air leak detector assembly acting as a seal to prevent air from entering back into the air leak detector, but permitting air from the air leak detector to flow out the valve seal. Similarly, claim 1 of the '346 patent, discloses a "one-way waterless valve means associated with

the fluid collection chamber and being operative, unaided by water seals, to permit air to flow out of the air space while preventing reverse flow back into the collection chamber."

Genzyme proposes the these terms be construed to mean "a type of valve, also known as a check valve, that allows the flow of fluid in one direction but prevents flow in the reverse direction." Genzyme submits that this claim term, despite the use of the term "means" in some instances, should not be construed as a means-plus-function claim limitation because the term "one-way valve" is a commonly understood term in the chest drainage industry and, thus, itself conveys a sufficiently definite structure. *See* Personalized Media Comms., 161 F.3d at 704; Sage Prods., 126 F.3d at 1427-28. Genzyme urges the court to accord the term "one-way valve" its ordinary and accustomed meaning as a check valve. A check valve, is defined by Webster's Third New International Dictionary (1981 ed.) as "a valve that permits flow in one direction but prevents a reverse flow."

Atrium, on the other hand, focusing specifically on the claim term "one way waterless valve means," contends that these terms are subject to s. 112, para. 6. It argues that the term "one way valve" does not have a well known structure, but is defined simply by the function that it performs. Thus, while Genzyme argues that the phrase "one-way valve" is a description of a structural type of valve, Atrium argues that it is merely a functional description of a valve and contends that these claim terms are means-plus-function limitations. Atrium argues that the function associated with claim limitation at issue is "preventing reverse flow back into the collection chamber," while the corresponding structure is the "high precision flapper-type check valve" that is disclosed in the invention. In response, Genzyme argues that if the court accepts Atrium's arguments and finds that this term to be a means-plus-function limitation, the corresponding structure is not a "high precision flapper-type check valve," but more broadly a "check valve" and its structural equivalents.

The court will begin by determining whether the claim term at issue is drafted in means-plus-function form. If the court finds that it is, the court must next determine the associated function and corresponding structure. Otherwise, the court need only define the term itself.

Atrium bases its contention that the court should construe the "one-way valve" and "one-way ... valve means" as means-plus-function limitations on four arguments. First, Atrium argues that because the word "means" appears in the phrase "one-way waterless valve means" along with a recited function of "preventing reverse back flow into the collection chamber," a presumption arises that s. 112, para. 6 applies. Second, Atrium argues that the "one-way valve means" limitations do not include any structure to perform the recited function of "preventing back flow" which could take the limitation out of the scope of s. 112, para. 6. *See, e.g.,* Wenger Mfg., Inc. v. Coating Mach. Sys., 239 F.3d 1225 (Fed.Cir.2001) (holding that "air circulation means" was subject to s. 112, para. 6, because it recited the function of "circulating air through said reel," without reciting any structure for performing that function); Cortland Line Co. v. Orvis Co., 203 F.3d 1351, 1357 (Fed.Cir.2000) (holding that "means for connecting said second end plate to said first spool axle" was subject to s. 112, para. 6, because it used the term "means" without specifying any structure for performing the stated function). Third, Atrium argues that the recitation of "valve" in the claim limitation is not a detailed recitation of structure sufficient to perform the recited function, and thereby avoid the application of s. 112, para. 6, because there are many different types structures that can serve as one-way valves FN6. *See* Laitram Corp. v. Rexnord, Inc., 939 F.2d 1533, 1535 (Fed.Cir.1991) (holding that structural description that served merely to further specify the function of the recited means did not take the claims outside the scope of s. 112, para. 6); Unidynamics v. Automatic Prods. Int'l, Ltd., 157 F.3d 1311, 1319 (Fed.Cir.1998) (holding that "spring means tending to keep the door closed" did not connote sufficient structure to rebut the presumption that s. 112, para. 6 applied). Last, Atrium notes that several courts that have had the opportunity to construe claim limitations involving the phrase "valve means" have interpreted the claims as a means-plus-function limitation. *See, e.g.,* Ballard, 268 F.3d at 1359; Schawbel Corp. v. Conair Corp., 122 F.Supp.2d. 71, 79 (D.Mass.2000); Utah Medical Prods., Inc. v. Clinical Innovations Assoc., Inc., 79 F.Supp.2d. 1290, 1307-08 (D.Utah 1999).

FN6. For example, in his deposition, Dr. Elliot described ball valves and single disk valves as two types of one-way valves with distinct structures.

In response, Genzyme argues that while the claim terms include the word "means," they include sufficient structure to perform the required function, because the phrase "one-way valve" has a specific structural meaning to those skilled in the art. According to Genzyme, this distinguishes the phrase at issue from the above cases cited by Atrium. Genzyme thus reasons that because the claim terms impart sufficient structural detail, they are not means-plus-function limitations. *See TurboCare Div. of Demag Delaval Turbomachinery Corp. v. General Electric Co.*, 264 F.3d 1111 (Fed.Cir.2001) (holding that "compressed spring means" referred to a particular type of device and that therefore, the district court erred in construing the claim term as a means-plus-function element); *Greenberg v. Ethicon Endo-Surgery, Inc.*, 91 F.3d 1580, 1583 (Fed.Cir.1996) (construing the term "detent mechanism" as not invoking s. 112, para. 6, because it is generally understood in the mechanical arts to describe structure); *see also Personalized Media Comm.*, 161 F.3d at 704; *Sage Prods.*, 126 F.3d 1420.

The question of whether this element is a means-plus-function limitation turns on whether the phrase "one-way valve" connotes structure to those of ordinary skill in the art. *CCS Fitness*, 288 F.3d at 1369. Atrium, citing to the declaration of its expert, Dr. Roger D. Kamm, argues that it does not connote sufficient structure, but only describes a function. Dr. Kamm opines in his affidavit that:

The term "valve" does not have a generally understood structural meaning in the art, but instead has a broad range of potential structures. The other words in the claim limitations associated with the "valve means" are functional and do not structurally define the valve means, e.g. "one-way," ... "operative to prevent reverse flow," etc. These additional functional terms do not impact structural definition to the valve means.

Atrium argues that this conclusion is further supported by the above cited Federal Circuit cases, *Laitram Corp. v. Rexnord, Inc.*, 939 F.2d at 1535 and *Unidynamics*, 157 F.3d at 1319.

Genzyme, on the other hand, cites to numerous sources, including Atrium's own documents, non-party publications and testimony, expert testimony, and the specifications and prosecution histories of the patents-in-suit to establish that one-way valve is a well known structural term of art in the chest drainage field.FN7 In order to establish that the term "one-way valve" is a well understood phrase that connotes structure, Genzyme first notes that Atrium, in its own regulatory and technical documents describes its valves as one-way valves. For example, in its FDA submission regarding its Express product, Atrium told the FDA that "[t]he water seal chamber incorporates a one way check ... valve instead of a water column" and interchangeably referred to one-way valves as "check valves." Similarly, in Atrium's press releases and product release brochures, Atrium describes the Express device as employing a "mechanical one-way valve." Genzyme next points to Atrium's training manual for the Express device, which describes the "state-of-the-art vacuum protection valve" used within the device as a "mechanical one-way valve." Genzyme also cites to chest drainage industry articles that refer to "one-way valves." Along the same lines, it notes that its experts, along with James Brost, the president of a leading valve manufacturing company for the chest drainage industry, also agree that a "one-way valve" is also "known as a check valve" and that "one-way valve is a commonly understood term and is defined as a valve that allows flow in one direction but prevents reverse flow in the opposite direction." Mr. Brost's affidavit further states:

FN7. The court notes that while this inquiry requires both sides to cite to extrinsic evidence, such evidence is properly considered in order to establish how one of ordinary skill in the art would read the disputed claim language. *See Pitney Bowes, Inc. v. Hewlett-Packard Co.*, 182 F.3d 1298, 1309 (Fed.Cir.1999) ("consultation of extrinsic evidence is particularly appropriate to ensure that [the judges] understanding of

the technical aspects of the patent is not entirely at variance with the understanding of one skilled in the art").

One-way valves are well-known products in my industry and are available from a number of manufacturers. To a person knowledgeable of valves ... a one-way valve is connotative of a certain structural design, which have a physical barrier that can selectively prevent or allow the flow of a fluid. Such physical barriers used in one-way valves have included since the 1970s the shape of a circular flap or similar sized structure sized to obstruct the reverse flow of fluid through an opening or orifice under desired pressure conditions.

Genzyme also notes that numerous patents in the mechanical arts used the phrase "one-way valve" as identifying a type of valve structure. *See, e.g.*, U.S. Patent No. 4,100,735, col. 8, ln. 8 ("check valve or a one-way valve"); U.S. Patent No. 4,031,869, col. 3, lines 41-46 ("The one-way valve 12 ... is a well-known check valve which allows the fluid to flow therethrough in one-direction, but not in the reverse direction."); U.S. Patent No. 4,242,058, col. 4, lines 4-5 ("one-way valve or check valve ...").

Genzyme also draws support for its proposed construction from the patent specifications and prosecution histories themselves. The Abstract sections of the '844 and '346 patents disclose "a check valve effective when connected to receive air from the exhaust port of the bottle to prevent the backflow thereof into the system." The Preferred Embodiment identifies a "check valve 14" or a "high precision flapper-type check valve" located between the fluid collection chambers and the air chamber.

Based on its review of the parties' arguments and the applicable case law, the court finds that the term "one-way valve" connotes structure and therefore is not a mean-plus-function limitation. While it is true that-like the "detent means" and "detent mechanism" terms construed by the Federal Circuit in *Greenberg*, 91 F.3d at 1583-the term one-way valve "does not call to mind a single well-defined structure," as the court indicated in *Greenberg*, "the same could be said of other commonplace structural terms such as 'clamp' or 'container'". What is important is not simply that [it] is defined in terms of what it does, but that the term, as the name for structure, has a reasonably well understood meaning in the art." *Id.*

This conclusion also finds support in Federal Circuit's decision in *TurboCare*. There, the Federal Circuit held that a claim element should not be construed as a means-plus-function element where both the specification and prosecution history disclose only a specific type of device, and do not use the term at issue to refer broadly to any structure that can perform its function. *TurboCare*, 264 F.3d at 1121 (construing "compressed spring means" as a "compressed spring" not subject to s. 112, para. 6, because it is "a type of device with a generally understood meaning in the mechanical arts."). The Elliot patents do not simply claim a "valve means" that could encompass any valve FN8they are limited to a specific type of valve that has a generally understood meaning in the mechanical arts: a one-way mechanical "check" valve.

FN8. This distinguishes the *Ballard* case cited by Atrium. There, the claim simply referred to a "valve means," without imparting any additional detailed structure.

In addition, the court notes that even if the court had accepted Atrium's arguments and concluded that "one-way valve means" is a means-plus-function element, it nonetheless would not have accepted Atrium's argument that the corresponding structure would have been the specific "high precision flapper-type check valve." Instead, it would have reached essentially the same result by concluding that the corresponding structure is a "check valve" and its structural equivalents. Only a simple "check valve" is required to perform the function of the one-way valve means. *See Micro Chem.*, 194 F.3d at 1258 (s. 112, para. 6 does not "permit incorporation of structure from the written description beyond that necessary to perform the claimed function"); *see also Intel v. Broadcom*, 172 F.Supp.2d. 515, 534-35 (D.Del.2001).

Therefore, the court concludes that the terms "one-way valve means" and "one-way valve" mean "a type of

valve, also known as a check valve, that allows the flow of fluid in one direction but prevents flow in the reverse direction."

## **2. "waterless"**

The parties do not appear to dispute this term. Genzyme's claim construction brief, "for completeness," states that the meaning of a "waterless valve," quite simply, is "a valve in which water or fluid is not used to serve as a valve." This definition is consistent with the plain meaning of "waterless." The statements of the inventor to the patent examiner during the prosecution of the parent application to the '844 patent also support this definition. Dr. Elliot stated, in a response to the patent examiner, that "it is plain from the application and applicant's previous remarks that the 'waterless valve means' is intended to define a valve in which water or fluid is not used to serve as a ... valve." Atrium does not submit an independent definition of the term "waterless."

Therefore, the court will adopt Genzyme's proposed definition. "Waterless" in the context of the phrase "waterless valve" means "a valve in which water or fluid is not used to serve as a valve."

## **3. "means defining a flow path between the inlet tube and said one-way waterless valve"**

[20] The term "flow path" is used in various claims of the Elliot patents. Some claims use the "means defining" language, while others do not. The parties again sharply dispute whether these claim terms-"means defining a flow path" and "flow path"-invoke s. 112, para. 6.

Atrium contends that "means defining a flow path" is a means-plus-function claim limitation whose function is "defining a flow path for fluids to flow from the inlet to the one-way valve" and whose corresponding structure is "the disclosed relatively open and straight space above the fluid collection chambers." Atrium argues that this claim term is drafted in means-plus-function form because (i) the term "means" appears; (ii) the term "means" is associated with the claimed function of "defining a flow path;" FN9 (iii) the claim term does not include any structure to perform the recited function of "defining a flow path." In addition, Atrium relies on the latter of the above arguments to support its contention that the term "flow path" is a means-plus-function limitation, even in those claims where the term "means" is not used.

FN9. While Atrium asserts in its claim construction briefing that the claimed function is "defining a flow path," its experts opined in their expert reports that the function of the "means for defining a flow path" is "to pass fluid between the inlet and the one-way valve."

Genzyme submits that the term "flow path" means "a path along which air flows between specific points," arguing that in the context of the claims and specifications of the asserted patents, this meaning is apparent. It argues that the term "means defining a flow path" should have the same meaning, because that phrase is not a means-plus-function limitation. In support of this proposition, Genzyme contends that (i) the term "flow path" is readily understood to mean the path along which air flows between distinct points; (ii) the term "defining" does not constitute a function, within the meaning of s. 112, para. 6; and, (iii) regardless of whether "defining" constitutes a function, the boundaries of the flow path are clearly defined by the recited structure in the claims themselves of an inlet and a one-way valve.

The court finds that the claim term "means for defining a flow path," as used in the claim phrase "means defining a flow path between the inlet tube and said one way waterless valve," is not a means-plus-function limitation. While the phrase employs the term "means for," the court disagrees that "defining a flow path" is a function that corresponds to the means language. This is because the flow path itself is not functionally defined; rather, it is sufficiently defined in the claims by the recited structure of an inlet and a one-way

valve. The ordinary meaning of flow path is "a path along which air flows between distinct points." Where the end points are recited in the claims, the claim element is sufficiently structurally described. Further, while Atrium asserts that the term "flow path" does not have a generally understood structural meaning in the art, the court sees no reason not to define this term in accordance its plain and ordinary meaning.

In analyzing whether "defining" is a function that brings this claim limitation under s. 112, para. 6 and whether there is a sufficiently disclosed structure in the claims, both parties cite *Wenger Mfg., Inc. v. Coating Mach. Sys.*, 239 F.3d 1225 (Fed.Cir.2001). In *Wenger*, 239 F.3d at 1237, the Federal Circuit affirmed the district court's holding that the claim term "means for defining a plurality of separate product coating zone" was not subject to the statutory means-plus-function provision. While the holding that "means for defining" was not a means-plus-function limitation in the patent at issue in *Wenger* does not necessarily translate to a similar conclusion as to the "means for defining" limitation at issue in the Elliot patents, a review of *Wenger* is instructive. There, the court stated that although a presumption arises that s. 112, para. 6 applies, because of the use of the term "means," *see Personalized Media*, 161 F.3d at 703, it was "unclear whether there is any function recited that corresponds to the word 'means.'" *Wenger*, 239 F.3d at 1237. The court went on to conclude that even if the function of "defining" were the function that corresponds to the word "means," s. 112, para. 6 would not apply because the claim recites structure that "defines" (i.e., establishes the boundaries of) the claimed separate product coating zones. *Id.* Specifically, the court found that the claimed "separate product coating zones" were defined by the structural recitation of spray nozzles directed toward the sidewall of the reel and spaced longitudinally along the reel. *Id.*

In this case, the court finds that the term "defining" is not a functional term. The term "defining," as used in the relevant claims, simply indicates that the path is described in terms of its end points. Moreover, as in *Wenger*, the boundaries-or end points-of the flow path are defined by the recited structure of the inlet and one-way valve. *See also Sage Prods.*, 126 F.3d at 1427-28 ("[W]here a claim recites a function, but then goes on to elaborate sufficient structure, material, or acts within the claims itself to perform entirely the recited function, the claim is not in the means-plus-function format" even if the claim uses the term "means"). Therefore, the court agrees with Genzyme that this claim term is not a means-plus-function limitation,FN10 and that "means for defining a flow path" has the same meaning as "flow path"- "a path along which air flows between the distinct points." These distinct points, the inlet and the one-way valve, are recited in each of the claims that use the term "flow path." FN11

FN10. The fact that the patent drafter seemed to draft the same terms both with and without "means" language (e.g., "flow path" and "means for defining a flow path," "one-way valve" and "one-way valve means") indicates an overzealous use of the word "means." These terms, which clearly relate to the same elements of the invention, are not always claimed in means-plus-function format throughout the claims. This lends further support to the court's conclusion that these terms are not "means-plus-function" limitations, because the presumption that arises by virtue of using the term "means" is overcome due to the recitation of sufficient structure.

FN11. Furthermore, the court notes that even if it were to find that the term was a means-plus-function limitation, it finds no support in the intrinsic record for the narrow definition of structure proposed by Atrium-"the relatively open and straight space above the fluid collection chambers." As far as the court can see, the terms "relatively open" and "straight" are found nowhere in the patents-in-suit.

The term "flow path" also is used without any "means" language in both claim 1 of the '370 patent-in the phrase "said inlet tube, air space, and air defining an air flow path"-and in claim 17 of the '844 patent-in the phrase "said one-way waterless valve means interposed along the flow path defined for the chamber toward the outlet." Because no means language is used, no function is recited, and the claims set forth the structural

boundaries that define the flow path.FN12 the court concludes that these claim terms are not governed by s. 112, para. 6. Therefore, the court will simply accord the term "flow path" the same ordinary meaning it stated above "a path along which air flows between the distinct points."

FN12. Genzyme's experts, Drs. Kerwin and McDonald both stated in their affidavits that a person skilled in the art would understand "flow path" to be a path along which air flows between distinct points, both of which are recited in each claim.

#### 4. "water seal"

[21] The Elliot patents state that certain alleged shortcomings of the prior art chest drainage systems can be overcome by "eliminating all underwater seals." Indeed, several claims of the Elliot patents require that the device be a "non-water seal" device, or to operate "unaided by water seals." This requirement is further confirmed by the prosecution history, which states that the invention is a dry seal that "completely omits the water seal."

Atrium submits that the term "water seal" means "a fluid filled structure that allows air to escape from the patient and prevents back flow of air to the patient under certain circumstances, but which allows back flow to relieve high negative pressure." It bases this proposed construction partially on the patent specification and partially on the declaration of its expert, Dr. Kamm.

The '844 specification states that "a so-called 'water-seal' ... is nothing more than a bottle to receive the drained fluids and air that is partially filled with ... water ... that has the chest drainage tube from the patient opening beneath the surface of this body of liquid so that the air cannot return by the same route." FN13 In addition, Dr. Kamm adds that although a water seal prevents back flow of air to the patient under certain circumstances, under high negative pressure, a water seal allows reverse flow of air to relieve the high negative pressure so that a patient is less likely to be exposed to an unsafe level of vacuum.FN14 Atrium's proposed definition is a synthesis of the two above statements.

FN13. Along the same lines, the dictionary defines a water seal as "a seal formed by water to prevent the reverse flow of gas."

FN14. Genzyme's expert agrees that under certain conditions-high negative pressure-air indeed would flow in the reverse direction.

Genzyme did not submit a proposed definition for this term in its opening brief, but argues in its reply brief that Atrium's definition is flawed. Genzyme notes that the term "water seal" is clearly defined by reference to the specification alone, and urges the court not to incorporate the second part of Atrium's proposed definition, drawn from Dr. Kamm's statement. Genzyme contends that Atrium seeks a construction of "water seal" that is not really a water seal, i.e., that a water seal would allow reverse flow to relieve high negative pressure, in certain circumstances.

The court agrees with Genzyme. The court need not supplement the definition of a term with extrinsic evidence, where that term is expressly defined in the patents. In addition to the statement quoted above, the '844 patent specification adds that "the sole function of the so-called water seals in the prior art chest drainage systems is that of preventing the backflow of air into the patient's chest cavity." Moreover, the ordinary meaning of water seal does not reference reverse flow in certain circumstances. Instead "water seal" is defined simply as "a seal formed by water to prevent the passage of gas."

Therefore, because the term "water seal" is expressly defined in the patents and because that definition simply states the ordinary meaning of the term, that definition should control. *Vitronics*, 90 F.3d at 1582. "Water seal" means "a fluid filled structure that allows air to escape from the patient but prevents the back flow of air to the patient." The parties may argue as to whether and when such devices break down at certain high negative pressure levels, but that has no bearing on the court's construction of the meaning of the term itself.

**5. "air leak detector," "air leak detector means," "U-shaped path," "U-tube," and "combination negative pressure indicator and air leak detector"**

[22] Several claims of the Elliot patents recite an "air leak detector" in various forms. For example, claim 21 of the '844 patent and all asserted claims of the '346 patent require "an air leak indicator means;" claims 5 and 6 of the '844 patent require a "U-shaped fluid path" providing an indication of air passing through; all asserted claims of the '370 patent require "a U-tube" providing an indication of air leaks; and all asserted claims of the '856 patent require a "combination negative pressure indicator and air leak detector assembly." As described above, the U-tube structures disclosed in the Elliot patents, when filled with fluid, allow air leaks from the lungs to be observed as bubbles flowing through the fluid. The Figures reproduced below depict the U-tubes (reference numbers 62 and 62A) shown in the various Elliot patents.

From Fig. 1 of the '844 patent

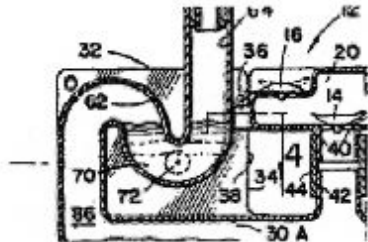

From Fig. 1 of the '370 patent

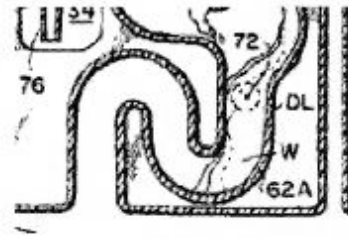

Atrium urges the court to adopt an identical definition for each of these claim terms, which is "an air leak detector or U-tube that is not a water seal." Atrium contends that these claim elements cannot be water seals due to numerous and specific statements in the patent specifications and prosecution history, which so constrain the scope of this element. *See e.g.*, *SciMed*, 242 F.3d at 1344.; *Ballard*, 268 F.3d at 1359.

Genzyme, which did not address this element in its opening brief, does not dispute that these elements are limited in the patent specifications and prosecution history, but contends, in its reply brief, that Atrium's analysis is imprecise. The proper construction, according to Genzyme, focuses not on the structures themselves, but on the fluid contained in the structures at issue. Thus, Genzyme submits, the court's construction should preclude coverage of *fluid* contained in an "air leak indicator means," "U-shaped path," "U-tube," or "combination negative pressure indicator and air leak detector" that is a water seal effective to prevent the return of air to the patient.

To resolve this minor dispute, the court turns to the specifications and prosecution histories of the Elliot patents. The '844 patent and '346 patent provides that "the fluid 70 within U-tube 62 is not a water seal effective to prevent the return of air to the patient." *See* '844 patent, col. 5, lines 40-45; '346 patent, col. 5, lines 42-47. The '844 specification further explains that no "fluid seal" is present in the claimed device,



"because the fluid in the U-tube is fully capable of passing air in either direction, i.e., back into the patient as well as out." '844 patent, col. 6, lines 5-9. The specification of the '856 patent, similarly states that "the fluid in the upstream U-tube remains ineffective to form a fluid seal." '856 patent, col. 4, lines 17-18. During the prosecution of the '920 application, which is incorporated by reference into the '370 and '856 patents, the applicant distinguished the prior art from the claimed device by stating that "the U-tube 62 of the applicant's invention is not a water seal." Similarly, during prosecution of the '992 application, the applicant again stated that the claimed device "explicitly requires that the one-way waterless valve means [is] operative to prevent reverse flow unaided by underwater seals and comprising the sole means thereof."

It is clear from the above excerpts that the scope of the claimed "air leak detectors" do not include structures which act as water seals, and that the claims should be interpreted so as to exclude from their permissible scope any interpretation that would cover a water seal. The parties do not dispute this. The court must determine, however, whether this limitation should be addressed to the fluid within the structure or to the structure itself. Based on the above statements from the specification and the prosecution history, it seems that the reason that a given air leak detector acts or does not act as a water seal, may be based on the fluid used. Accordingly, the court thinks it is sufficient to simply exclude air leak detectors that act as water seals. The court will adopt the following as its construction of claimed "air leak detectors" (including the claim terms "air leak indicator means," "U-shaped path," "U-tube," or "combination negative pressure indicator and air leak detector"): "an air leak detector or U-tube that does not act as a water or fluid seal."

#### **IV. Claim Construction of the D'Antonio '531 Patent**

##### **A. The Parties' Positions**

###### **1. Disputed Claim Terms**

Before turning to the disputed claim terms of the D'Antonio patent, the court will briefly review the asserted claims of that patent in order to give the proper context to those terms. Independent claim 1 of the D'Antonio patent, which the court reproduces below, discloses:

A system for draining fluids from a portion of the body, said system comprising:

collection means for receiving fluids from the body, said collection means including an inlet port for admitting fluids from the body to said collection means;

a suction chamber communicable with said collection means, said suction chamber being connectable to a suction source of a suction pressure level;

a suction regulator for establishing a desired pressure in said suction chamber, said suction regulator including

a first compartment having a first chamber communicating with the atmosphere;

a second compartment having a second chamber communicating with said suction chamber and having an outlet for connecting said second compartment and the suction source;

first dividing means dividing said first chamber from said second chamber, said first dividing means including an opening for putting said second chamber in communication with said first chamber;

first closing means movable between an opening position for opening said opening to admit air at

atmospheric pressure into said second chamber, and a closing position for closing said opening to prevent the passage of air at atmospheric pressure into said second chamber; and

biasing means for moving said closing means to the closed position when the pressure in said suction chamber exceeds said desired pressure to preferentially apply said suction pressure level to said suction chamber when the pressure in said suction chamber is greater than said desired pressure, and said closing means moving to said open position when the pressure in said suction chamber is less than said desired pressure.

'531 patent, col. 11, I. 49-col. 12, I. 17.

Claim 16, also an independent claim, shares a number common elements with claim 1, including the "collection chamber," "the suction chamber," and "the suction regulator." The suction regulator is claimed in claim 16 as having "an opening for admitting atmospheric air to increase the pressure in said suction regulator and closing means for closing said opening." Claim 16 also discloses a "means for applying a force to said closing means to move said closing means to a predetermined position" and a "damping means for damping the force applied by said closing means."

Claims 17 and 18 are dependent claims that depend from claim 16. Claim 17 discloses "[t]he invention according to claim 16 wherein said damping means comprises a dash pot." Claim 18 discloses "[t]he invention according to claim 16 wherein said predetermined position is a position closing said opening, and said force applying means comprises biasing means for biasing said closing means to said closing position."

The parties dispute the following claim terms in the D'Antonio patent.

-> "suction chamber"-as used in claims 1 and 16 of the D'Antonio patent.

-> "dividing means"-as used in claim 1 of the D'Antonio patent.

-> "closing means"-as used in claims 1, 16, 17, and 18 of the D'Antonio patent.

-> "second chamber communicating with said suction chamber and having an outlet for connecting said second compartment and the suction source."-as used in claim 1 of the D'Antonio patent.

-> "biasing means" to "preferentially apply" suction-as used in claims 1, 16, 17, and 18 of the D'Antonio patent.

-> "damping means"-as used in claims 16, 17, and 18 of the D'Antonio patent.

## **2. Genzyme's Position on D'Antonio Patent Terms**

Genzyme submits that the term "suction chamber" means a chamber of regulated pressure connectable to a source of suction and a suction regulator, and which applies suction to a collection chamber. It asserts that first/second compartment and first/second chamber are defined as follows: the first compartment and second compartment refer to structural portions of a suction regulator, each portion having a chamber. The first chamber refers to a space that communicates with the atmosphere, and the second chamber refers to a space that communicates with the suction chamber.

Further, Genzyme submits that the term "dividing means" refers to a divider, such as a partition, that divides the first chamber from the second chamber. Genzyme next contends that the term "closing means" refers to a closing member, such as a ball, hinged door, or other gas port closing means, which can open or close an

opening in a suction regulator. Genzyme asserts that the term "damping means" refers to a damping device, such as a dash pot, for damping the applied force in the suction regulator. Genzyme argues that the term "biasing means" refers to a spring, which allows for the closing means to be moved to a predetermined position. Last, Genzyme asserts that the term "preferentially apply" means drawing air first from the patient, before atmospheric air is applied to the suction chamber when the closing means moves to the open position.

### **3. Atrium's Position on D'Antonio Patent Terms**

It is Atrium's position that the D'Antonios did not invent "dry" suction regulators; rather, they invented a certain type of dry suction regulator. In support of their position, Atrium refers the court to a number of prior art references that were discussed and distinguished during the prosecution of the D'Antonio '531 patent, including the Akiyama patent, the Zuhdi/Kimmel reference, and the Willrath patent.

As with the Elliot patents, Atrium seeks constructions that limit the meaning of claim terms to certain structures disclosed in the patent. Atrium also seeks constructions that expressly exclude certain structures that were present in the prior art that Atrium argues were distinguished from the invention of the D'Antonio patent during prosecution.

Atrium contends that Genzyme's constructions of dividing means as *any* divider, of damping means as *any* damping device, and of closing means as *any* closing member flies in the face of means-plus-function law. Instead, construing these terms to broadly cover any structure that can accomplish the claimed function, Atrium asserts that the scope of D'Antonio patent must be limited to those structures that accomplish the claimed function which are disclosed and not disclaimed. *J & M Corp.*, 269 F.3d at 1367 (noting that "[t]he literal scope of a properly construed means-plus-function limitation does not extend to all means for performing a certain function. Rather, the scope of such claim language is sharply limited to the structure disclosed in the specification and its equivalents. Moreover, the extent of equivalents must be interpreted in light of the disclosure of the invention in the specification, as a whole, as well as the prosecution history.").

Specifically, Atrium asserts that the term "dividing means" refers to the disclosed flat horizontal partition having an opening within it, which divides a first chamber at atmospheric pressure from a second chamber at suction pressure, but excludes cylindrical wall, or "valve seat," structures found in prior art. It also asserts that "closing means" refers to the disclosed spherical ball that fits within the opening in the "dividing means," which performs the function of opening and closing the opening in the "dividing means," but excludes a valve plug that covers a valve seat, as found in the prior art. These proposed constructions are based, in part, on statements made by the patentees during the prosecution of the '531 patent to distinguish their invention over the Zuhdi/Kimmel and Willrath prior art references. Additionally, Atrium submits that the term "damping means" refers to a disclosed dash pot structure of a piston within a cylinder that damps forces by the restriction of air flow in the cylinder, and which performs the function of damping forces applied by the closing means, but excludes a structure that damps forces by friction between the piston and cylinder wall.

Atrium also urges the following definitions as to the other disputed terms. "Second chamber communicating with said suction chamber and having an outlet for connecting said second compartment and the suction source" means a second chamber communicating with a suction chamber and having an outlet to the suction source that is separate from the second chamber's communication with the suction chamber. Atrium contends that this construction is based on the plain language of the claim, figures of the specification that together show two connections, and the fact that the "and having an outlet ..." claim language was added after the claims were rejected over prior art that only had one connection to a suction source. Last, as to the term "biasing means" to "preferentially apply," Atrium contends that there is no structure disclosed in the specification that corresponds to the "biasing means" that would perform the function of preferentially

applying suction. Therefore, it concludes that the claims that include this claim term is invalid as indefinite.

Thus, generally speaking, while Genzyme seeks to ascribe broad general meanings to the claim terms, Atrium seeks to limit the meaning of the claim terms to the specific disclosures of the patent. To accomplish its goal, Genzyme contends that claims should be given their ordinary meaning and not be limited to the preferred embodiments set forth in the specification. In contrast, Atrium contends that certain claim limitations are narrowly drawn, because (i) they are means-plus-function claims, whose corresponding structures are limited to those structures disclosed in the specification that accomplish the associated function, *see* 35 U.S.C. s. 112, para. 6; or, (ii) Genzyme narrowed the meaning of the claim terms by distinguishing certain prior art references during prosecution.

## **B. A Detailed Review of The Prosecution History of the D'Antonio Patent**

As many of Atrium's claim construction arguments are based on purported disclaimers or distinctions made by the patentees to obtain the '531 patent, it is important to first review the pertinent aspects of the prosecution history of the '531 patent before resolving the parties' disputes on claim construction. *Southwall Techs., Inc.*, 54 F.3d at 1576; *Ballard*, 268 F.3d at 1359.

The application that eventually matured into the D'Antonio '531 patent was filed as application number 07/058,573 (the '573 application) on August 6, 1987. The '573 application is a continuation of application 06/642,564 (the '564 application), which was filed on August 20, 1984 and issued as U.S. Patent No. 4,715,855 on December 29, 1987.

The court will review the relevant portions of the prosecution histories for both the '564 application and the related '573 application that ultimately issued as the D'Antonio '531 patent.

### **1. The '564 Application**

As noted above, and in the '531 patent itself, the '573 application, which resulted in the '531 patent, was a continuation of the earlier filed '564 application that ultimately matured into U.S. Patent No. 4,715,855 (the '855 patent). While the '531 patent and '885 patent share the same specification and figures, some claim language is different, and the '531 patent includes 9 additional claims. As statements made during the prosecution of this related application may impact the claim construction of the limitations of the '531 patent, the court will review the prosecution history of this application as well.

As originally filed, on August 20, 1984, the '564 application included 30 claims. Application claim 1 was identical to the original application claim 1 of the later filed '573 application and similar to claim 1 of the '531 patent. It claimed a "system for draining fluids from a portion of the body" that included "a collection means," "a suction chamber ... connectable to suction source," and "a suction regulator." The suction regulator included "a first ... chamber... communicating with the atmosphere," "a second ... chamber ... communicating with said suction chamber," "a dividing means" with an opening to divide the two chambers, "a closing means" for opening and closing the opening between the chambers, and "a biasing means."

In an Office Action, dated November 12, 1985, the Patent Examiner rejected claim 1 under 35 U.S.C. s. 102(a) as being anticipated by the Akiyama reference (U.S. Patent No. 4,533,353 issued to Akiyama on August 6, 1985). The Examiner concluded that Akiyama disclosed all of the structure as claimed, including the first and second chambers.<sup>FN15</sup> The Examiner also rejected claims 2, 3, 17, and 35 as obvious under 35 U.S.C. s. 103 and unpatentable over Akiyama.

<sup>FN15</sup> The Akiyama patent is entitled "Dry Type Discharge Liquid Extraction Device for the Thoracic Chamber." According to its abstract, the claimed apparatus includes a "fluid collection chamber, a coupling

for introducing vacuum into the fluid collection chamber, and a pressure control valve for regulating the flow of air from the collection chamber to the coupling. Also provided is a one-way check valve between the fluid collection chamber and pressure control valve and a vacuum pressure stabilizing valve which is vented to atmosphere and interposed between the pressure control valve and the coupling for selectively passing air at atmospheric pressure to stabilize the introduced vacuum."

In addition, the Examiner concluded that:

Claims 4-6 are rejected under 35 U.S.C. s. 103 as being unpatentable over Akiyama in view of Willrath et al. The patent to Willrath et al. teaches that it would have been obvious to provide the suction regulator of Akiyama with a different valve (Fig.2). To provide the collar upon which ball 12 seats with stabilizing notches would have been an obvious addition to the device.

Claims 4-6 are dependent claims that depend from claim 1; all further specify that the opening referred to in claim 1 is a circular opening and that the closing means claimed in claim 1 is "of generally spherical configuration." Figure 2 of the Willrath German patent, reproduced below, discloses a mechanical suction regulator device that uses a ball attached to a spring mechanism to cover and uncover an opening that separates two chambers. The ball covers the opening by pressing against a valve seat that closes a valve.

**Figure 2 of the Willrath Patent**

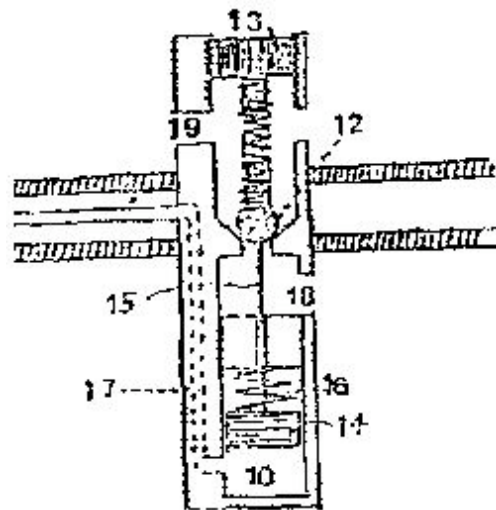

The Examiner also rejected claims 7-9, 10, 11, 15, 16, 22-24, 27-30 under 35 U.S.C. s. 103 as being unpatentable over Akiyama in view of various combinations of secondary references. Last, the Examiner found that the remaining claims contained allowable subject matter, but were not claimed in technically correct fashion.

The Applicants responded to the Examiner's rejection of the above claims in a Response to Office Action on April 10, 1986. Therein, the Applicants amended the claims that the Examiner deemed allowable to correct technical deficiencies. The Applicants also argued that the Examiner should not have rejected the balance of the claims (including claim 1) as unpatentable. The Applicants explained that "the present invention provides

a regulator which *preferentially* draws air from the lung cavity instead of from the lung cavity, and provides an unobstructed and unrestricted path from the pressure source to the inlet port in the patient .... Drain systems heretofore, as well as the cited references, do not teach or suggest the unrestricted pressure path or the preferential draw aspects of the present invention." As such, the rejections based on Akiyama were unwarranted. The Applicants explained that

[u]nlike the present invention, wherein a single adjustable regulator establishes the pressure in the suction chamber and to the chest cavity, Akiyama teaches two regulators together with a pressure stabilizing valve. Further, Akiyama '353 includes an obstruction (suction pressure adjustment pressure valve 2) between the suction source and the suction chamber and inlet port .... This arrangement does not preferentially draw from the lungs but rather draws atmosphere simultaneously .... Moreover, claim 1 is not obvious in view of Akiyama. There is nothing in the reference which teaches or suggests the "preferential draw" arrangement of the present invention or the unrestricted connection between the suction source and the suction chamber and inlet port.

With respect to the rejections of claims 4-6 in view of Willrath et al., the Applicants argued that as opposed to their invention, whose closing portion is responsive to pressures exerted on opposite sides thereof:

Figure 2 of Willrath shows a spherical element which appears to be responsive to a biasing spring and an element 15 which is actuated by a third pressure source 10. Further, the spherical element [of the Willrath patent] is not disposed "within" the opening FN16 [, whereas in their patent, the ball closes the opening by being disposed within the opening itself].

FN16. In Willrath patent, Figure 2, the spherical ball sits on top of the opening in a cone shaped structure; it does not sit within the opening itself, but covers the opening.

The distinction drawn by the Applicants between claims 4-6 of their application and the Willrath patent is illustrated below. In essence, the Applicants asserted that the inventions were distinct, because in Willrath the spherical ball was placed over the opening in the partition, rather than within the opening in the partition.

**\*319**

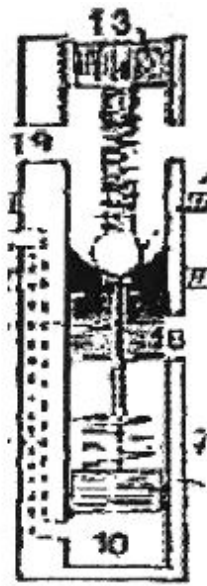

**Willrath Fig. 2**

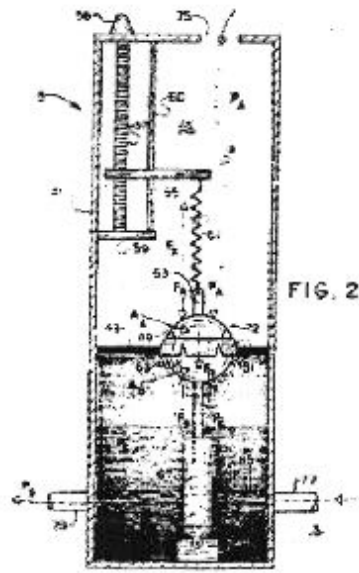

**D'Antonio Fig. 2**

On September 8, 1986, the Examiner issued a Final Office Action. Therein, he allowed the claims that he had previously deemed patentable but technically deficient. However, finding the Applicant's arguments as to the rejected claims unpersuasive, he maintained that the claims that he had previously rejected under 35 U.S.C. s.s. 102 and 103 were anticipated or obvious. The Examiner stated that although the Applicant argued that their invention is novel in that it allows for unrestricted flow, this feature was not present as a limitation in the claims. Moreover, the Examiner disagreed that the Akiyama device could not "preferentially draw" air from the patients lungs, noting that "[i]f Akiyama's device drew only from the atmosphere, it would be a useless device."

Applicants responded to this Final Office Action by filing an Amendment After Final Rejection on February 17, 1987. Claim 1 was amended "to improve its form and to positively recite the preferential draw feature discussed above." Among the changes were the addition of the following underlined language: (i) a second compartment having a second chamber communicating with said suction chamber *and having an outlet for connecting said second compartment and the suction source*; (ii) first closing means movable between an opening position for opening said opening *to admit air at atmospheric pressure into said second chamber* ....; (iii) biasing means ... *to preferentially apply said suction pressure level to said suction chamber when the pressure in said suction chamber is greater than said desired pressure* ....

Then, the Applicants again argued that the feature of "preferential draw" distinguishes their invention from that of Akiyama. They explained that the Examiner misunderstood their argument as stating that the Akiyama device draws only from the atmosphere. This, the Applicants stated, was not what they meant. Rather, the Applicants explained,

Akiyama does not have the "preferential draw" feature because Akiyama always draws from the atmosphere, even when drawing from the patient .... This is very different from the present invention wherein air is drawn preferentially only from the patient until there is excess suction applied-only at which time atmospheric air is admitted into the system from a single source.

In light of these arguments and amendments, the Applicants requested that the application be allowed.

On March 17, 1987 the Examiner issued an Advisory Action. Therein, he concluded that his final rejection would stand and the Applicants proposed amendment would not be entered because they raise new issues that would require further consideration and/or search and because no convincing showing was made as to why the proposed amendment was necessary. Thus, application claims 1-5, 10, 11, 15-17, 22, 25, and 27-30 remained rejected, while claims 12-14, 18-21, 23, 24, and 26 were allowed and later issued as part of the '885 patent.

In a May 7, 1987 amendment, the Applicants noted that the rejected claims had been cancelled and would be refiled in a continuation application.

## **2. The '573 Continuation Application**

The '573 application, a continuation of the '564 application, was filed on August 6, 1987. As originally filed, it had 30 claims, with three independent claims (claims 1, 27, and 30) and twenty-seven dependent claims.

Like claim 1 of the D'Antonio patent, claim 1 of the '573 application claimed both "a suction chamber ... connectable to a suction source" and a suction regulator having a second chamber of a second compartment "communicating with said suction chamber." Application claim 1, as originally filed, did not include additional language present in claim 1 of the D'Antonio patent requiring the second chamber of the second compartment to "hav[e] an outlet for connecting said second compartment and the suction source."

As originally filed, the description of the preferred embodiment of the '573 application explains that the lower chamber of the claimed suction regulator "includes an entrance port 77 from suction chamber 3, and is connected to the hospital suction source [through a port] 79 at pressure  $P_s$ . Port 79 could be located in some other wall defining suction chamber 3." The language relating to suction chamber 3 and the last sentence of the above excerpt were deleted in subsequent versions of the written description, pursuant to a preliminary amendment filed prior to the first Office Action.

In that same preliminary amendment, the portion of claim 1 relating to the second compartment having a second chamber was revised to read: "a second compartment having a second chamber communicating with said suction chamber *and having an outlet for connecting said second compartment and the suction source.*" The applicants also made a number of other changes were made to the claims of the application, and requested that claims 6-9, 12-14, 18-21, 23, 24, 26, 29, and 30 be cancelled. In addition, new claims 31-35 were added to the patent application. The remarks accompanying the preliminary amendment stated that the amendments "have been made to place the application in better form for examination and to more particularly point out and distinctly claim Applicant's invention." Thus, the changes made by preliminary amendment to the '573 application were the same changes that the applicants desired to make by amendment after the final rejection of the '564 application. The purpose of the amendments was to more precisely claim the preferential draw feature of the invention.

Thereafter, on December 30, 1987, the applicants filed a second preliminary amendment, adding claims 36-38 "to include an embodiment of applicant's invention not previously examined."

On March 28, 1988 the Patent Examiner issued an Office Action that (i) rejected all the claims from claims 1-35 that were presented for examination (application claims 1-5, 10, 11, 15, 16, 17, 22, 25, 28, and 31-35) and (ii) withdrew claims 36-38 from further consideration as being drawn to a non-elected invention, pursuant to C.F.R. s. 1.142(b). The rejected claims were rejected under 35 U.S.C. s. 103 as being unpatentable over the Akiyama patent in view of the Helfgott patent (U.S. Patent No. 4,324,243 issued to Helfgott et al. on April 14, 1982). The Examiner explained that:



Akiyama is considered to show all of the claimed elements except the biasing and closing means. Helfgott shows a biasing and closing structure at Figure 3 used to control pressure in the apparatus FN17. Modification of Akiyama to incorporate the biasing and closing means of Helfgott to control the admission of atmospheric air into the unit would be obvious in view of the showing of Helfgott.

FN17. The Helfgott patent is directed at "[a]n apparatus and process for aspirating and evacuating a pneumatically operated surgical instrument." Figure 3 of the Helfgott patent depicts the adjustable pressure valve of the invention, that includes a valve body including a valve seat in an air tight relationship with a receptacle lid attached to a valve stem that is threaded into a nut. A spring disposed around the valve stem and between the nut and valve body serves to bias the surface of the valve member against the valve seat.

The Applicants responded to the Office Action in a Response, dated July 28, 1988. Therein, Applicants argued that the claims that the Examiner rejected as being obvious from Akiyama combined with the teachings of Helfgott should be allowed. First, the Applicants noted that their fluid drainage system was superior to prior art systems in that it provides "a more precise and controlled regulation of fluid flow, as well as fluid regulation and collection." Next, and more significantly, the Applicants asserted that Akiyama did not show or teach all of the claimed elements of their invention "except for the biasing and closing means." Specifically, the Applicants again argued that, in contrast to their invention:

the Akiyama arrangement draws "air" simultaneously from the atmosphere. Akiyama does not disclose nor have the "preferential draw" feature as claimed by Applicants because Akiyama *always* draws air from the atmosphere, even when drawing from the patient .... In the present invention, air is preferentially and exclusively drawn from the patient until predetermined pressure conditions are met—a feature not found in Akiyama .... Helfgott et al. does not overcome the above listed deficiencies of Akiyama nor is there a disclosure or teaching present in this patent to suggest the proposed modification of the Akiyama device as set forth in the rejection to arrive at the claimed dry bottle system.

Thereafter, the Examiner and the attorney for the Applicants, D. Peter Hochberg, engaged in a telephone interview on September 19, 1988. The interview summary document, dated September 26, 1988, indicates that the Applicants "[a]greed to cancel the non-elected claims 36-38 by Examiners Amendment" and that "[t]he remaining claims [would be] allowed over the art of record." On that same date, the Examiner issued a Notice of Allowability allowing application claims 1-5, 10, 11, 15-17, 22, 25, 27, 28, and 31-35. In the '531 patent, these claims are renumbered as claims 1-19.

On August 29, 1989, well after the Applicants received the Notice of Allowability and made payment of the issue fee, the Applicants filed a "Disclosure of Art." The Applicants explained that they had only recently become aware of the existence of a prior art reference, an article by N. Zuhdi and G. Kimmel entitled "Vacuum Regulator for Cardiotomy Return and Chest Drainage Systems," which was published in the *Journal of Thoracic and Cardiovascular Surgery* in February 1960. The brief three page article purports to describe a "small, inexpensive, simple, durable, and accurate vacuum regulator" for use in "cardiotomy return and pleural cavity drainage." The article contains three short paragraphs of text and five figures. It does not go into a great deal of detail in describing the disclosed device, but notes that its figures detail the appearance of the regulator and its construction.

The court reproduces the most detailed drawing and description of the device disclosed in the article below, Figure 2 of the Zuhdi/Kimmel article:

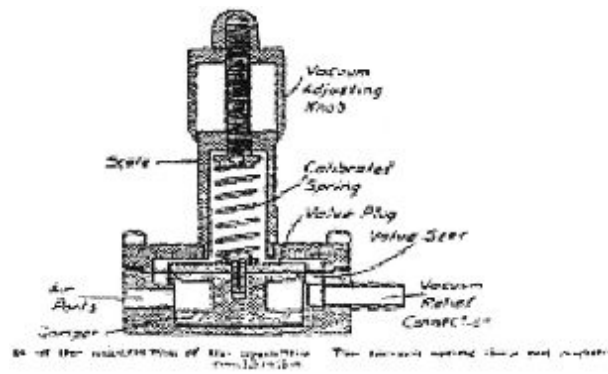

According to the Figure 2, the device contains a vacuum adjusting knob, a scale, a calibrated spring, a cylindrical valve plug, a flat valve seat, several air ports, and a vacuum relief connection. By way of explanation, the article states that "[t]he knob applies a force through an Incomel spring to a seat disc which reacts to the vacuum and regulates the amount of room air admitted into the line connecting the source of suction to the container."

It also appears from the blown up portion of Figure 2 below, that some sort of diaphragm or membrane structure is placed between the valve plug and damper. This structure is not referenced or explained in the article.

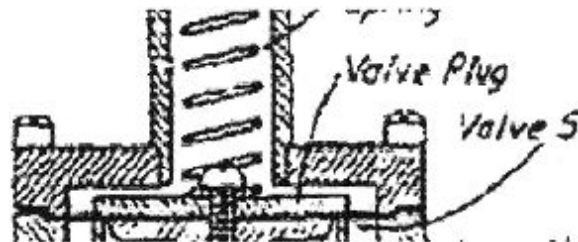

In their Disclosure of Art, the Applicants explained to the Examiner that the Zuhdi/Kimmel article:

describes a device for regulating the amount of suction applied to the cardiotomy return system during open heart surgery, or to the pleural cavity following cardiopulmonary surgery. The device taught consists of a valve device whose plug is controlled between its open and closed positions by means of the force exerted by an adjustable spring. The device is used in connection with other apparatus that serves as a suction reservoir, or to measure blood loss. Applicants have been unable to obtain more information concerning the device, notwithstanding their attempts to do so.

The Applicants went on to distinguish the Zuhdi/Kimmel device from their invention, noting that:

[d]espite some apparent similarities in objectives between the device shown in the Article and the Applicant's invention, Applicants believe that one skilled in the art would be unable to understand from the Article that its disclosure would anticipate or make obvious the features of Applicant's device. For example, Applicants teach and claim a suction regulator having dividing means between its first and second chambers, with an opening therein. Applicants also teach and claim means for closing the opening in the

dividing means. Neither of these features appear to be disclosed in the Article.

The inventors of the D'Antonio patent, Nicholas F. D'Antonio and Nicholas J. D'Antonio, explained in subsequent depositions that they did not and still do not understand how the regulator disclosed in the Zuhdi/Kimmel article works.

The Disclosure of Art is the final entry in the prosecution history of the '531 patent that has been provided to the court. Accordingly, the court assumes that the Applicants and Examiner had no additional correspondence regarding the Zuhdi/Kimmel article.

## **C. The Court's Claim Construction of the D'Antonio Patent's Terms**

### **1. "suction chamber"**

[23] The claim term "suction chamber" is recited in both of the asserted independent claims 1 and 16 of the D'Antonio patent, as one of the elements included in the claimed "system for draining fluids from a portion of the body." Both claims disclose "a suction chamber communicable with said collection means [or first collection chamber], said suction chamber being connectable to a suction source."

Genzyme proposes that the proper construction of the term "suction chamber" is "a chamber of regulated pressure connectable to a source of suction and a suction regulator, and which applies suction to a collection chamber." In its briefing, Atrium did not offer its own competing definition of this term.

The Abstract of the D'Antonio patent discloses a fluid drainage system having a "suction chamber with a suction regulator." The Summary of Invention further states that "a more specific object [of the invention] is to regulate the pressure of a suction chamber relative to the atmosphere by means of an economical yet effective device," the disclosed suction regulator. The suction chamber is described in the Description of the Preferred Embodiments as "a suction chamber 3 from which air can be evacuated by an external vacuum source," which contains a suction port 4 "for interconnecting chamber 3 with the external vacuum source." That section also describes "a suction regulator 5 for controlling the pressure in chamber 3," as well as the other elements of the invention.

As Genzyme's definition finds support in the claim language itself and in the specification of the D'Antonio patent, the court will adopt that as its construction of this term. "Suction chamber," as used in the D'Antonio patent, is "a chamber of regulated pressure connectable to a source of suction and a suction regulator, and which applies suction to a collection chamber."

### **2. "dividing means"**

[24] Claim 1 of the D'Antonio patent recites a "first dividing means dividing said first chamber from said second chamber." The parties agree that this limitation is a means-plus-function limitation subject to s. 112, para. 6. This is because the claim element uses means language, recites a function, and does not recite a structure that performs this function, i.e., dividing means is not understood to connote structure that performs the recited function; rather it is stated in purely functional terms. As such, the court must construe both the claimed function and the corresponding structure associated with "dividing means" that is disclosed in the specification.

The parties do not dispute the function of the dividing means. It is clear from the claim itself that the function of the dividing means is dividing the first chamber of the suction regulator (which is kept at atmospheric pressure) from the second chamber (which is kept at suction pressure). The parties dispute, instead, centers on the proper corresponding structure.

Genzyme submits that the corresponding structure is a divider, such as a partition, that divides a first chamber from a second chamber. Atrium, however, contends that, due to the limited disclosure in the specification and disclaimers made during prosecution of the patent, the corresponding structure is limited to the disclosed flat, horizontal partition having an opening with it, and that it specifically excludes cylindrical wall, or valve seat, structures as found in the prior art Zuhdi/Kimmel article.

Atrium draws support for its proposed construction from both the specification and the prosecution history of the D'Antonio patent. First, it addresses the specification. In its opening brief, it reasons that the only structure described in the D'Antonio patent for dividing the first chamber from the second chamber is the "flat, horizontal partition (43)" shown in Figure 2 of the patent. *See* '531 patent, col. 5, ln. 13-15 (the claimed device includes "a horizontal partition 43 dividing regulator 5 into an upper chamber 45 and a lower chamber 47"). The specification also describes the partition as including within it "an opening 49," which puts the second chamber in communication with the first chamber. *Id.*, col. 5, ln. 16. Therefore, Atrium concludes that the scope of the means-plus-function limitation must be sharply limited to the sole disclosed structure and its equivalents. *See* J & M Corp., 269 F.3d at 1367 ("The literal scope of a properly construed means-plus-function limitation does not extend to all means for performing a certain function. Rather, the scope of such claim language is sharply limited to the structure disclosed in the specification and its equivalents.").

While the preferred embodiment of the '531 patent describes only "horizontal partition 43" as the structure that corresponds to the "dividing means," that section of the patent is not the only section that references the dividing means. The Abstract and Summary of Invention sections of the '531 patent also disclose "high and low pressure chambers separated by a divider" and "a divider separating the chambers." It is apparent from these uses, that the inventors used the term divider in accordance with its common and accustomed meaning as "something serving as a partition between separate spaces within a larger area." Webster's Third New Int'l Dictionary (1981 ed.).

[25] The Federal Circuit instructs that when construing the corresponding structure for a means-plus-function element, the court should include all alternative structures described in the specification, and not simply the preferred embodiment. *See* *Budde v. Harley-Davidson, Inc.*, 250 F.3d 1369, 1379 (Fed.Cir.2001); *Micro Chem.*, 194 F.3d at 1258. Moreover, "[a]ll that one needs to do to obtain the benefit of that [means-plus-function] claiming device is to recite some structure corresponding to the means in the specification, as the statute says, so that one can readily ascertain what the claim means ..." *Atmel Corp. v. Information Storage Devices, Inc.*, 198 F.3d 1374, 1382 (Fed.Cir.1999).

Based on the disclosures in the specification, the court finds that the corresponding structure of the "dividing means" is either a partition or divider.FN18 Atrium urges the court to further limit its construction of the corresponding structure to only horizontal partitions.FN19 It argues that because "horizontal partition 43" is the only partition disclosed, that and exactly that is the only structure that they can claim coverage over. The court declines to limit the "dividing means" to partitions having a horizontal orientation. The invention does not require the dividing means to possess any particular orientation. Moreover, the orientation of the dividing means is irrelevant to the recited function of dividing the two chambers. Therefore, limiting the dividing means to a structure having a certain specific orientation would improperly import limitations into the claim language. *Micro Chem.*, 194 F.3d at 1258 ("the [means-plus-function] statute [does not] permit incorporation of structure from the written description beyond that necessary to perform the claimed function.").

FN18. That an opening is required in this structure is not disputed. This requirement is specifically called for by the claim itself, which states: "said dividing means including an opening for putting said second chamber in communication with first chamber." In addition, the function of the claimed "closing means" is to open and close the opening in the "dividing means."

FN19. Atrium also seeks to limit the corresponding structure to a "flat" partition. Such a limitation, however, is improper as the '531 patent does not even use the word flat to describe the partition.

Atrium complains that a construction of "dividing means" as covering "any divider" fails to follow the rules of construing means-plus-function limitations. However, because the specification here simply describes the structure of the claim element as a generic partition or a divider, without offering more specific structure, it would be erroneous to construe the corresponding structure more narrowly. Moreover, any such limitation would be mooted by the fact that the patentee is entitled to the corresponding structure and structural equivalents thereof. To the extent the court had agreed to limit the partition to a partition with a particular flatness or orientation, where those limitations are irrelevant to the claimed function, Genzyme could still be entitled to a scope of equivalent structures that includes partitions that are not so limited.

Atrium further argues that the scope of structures covered by the "dividing means" limitation should also be limited by the positions taken by the applicants during the prosecution of the D'Antonio patent. *See* *Alpex*, 102 F.3d at 1221; *Ballard*, 268 F.3d at 1359. Specifically, Atrium contends that during prosecution, the applicants submitted an article, entitled "Vacuum Regulator for Cardiotomy Return and Chest Drainage Systems," which was published by N. Zuhdi and G. Kimmel in February 1960 in the *Journal of Thoracic and Cardiovascular Surgery*. The Zuhdi/Kimmel article describes the design and performance of a vacuum regulator device for controlling the amount of suctions applied to a patient by a chest drainage system, by using a valve device whose plug is controlled between its open and closed positions by means of a force exerted by an adjustable spring. Atrium argues that the applicants distinguished their claimed device from the structure disclosed in the Zuhdi/Kimmel article and thus disclaimed coverage of the "cylindrical wall" and "valve seat" structures described in the Zuhdi article. *See* *Pall Corp. v. PTI Tech. Inc.*, 259 F.3d 1383, 1394 (Fed.Cir.2001) (subject matter disclaimed during prosecution is excluded from permissible scope of claims). The purported disclaimer that Atrium relies on is the following statement made by the applicants to the PTO in their August 4, 1989, "Disclosure of Art" FN20:

FN20. As noted above, this statement was made after the Applicants received a Notice of Allowability for the '531 patent in September 26, 1988. The Applicants explained that "it was not until recently in 1989 that Applicants became aware of the existence of the cited Article, and so could not have presented it prior to the latter date."

The device taught [in the Zuhdi article] consists of a valve device whose plug is controlled between its open and closed position by means of a force exerted by an adjustable spring .... Applicants have been unable to obtain more information about the device, notwithstanding their efforts to do so.

Despite some apparent similarities in objectives between the device shown in the Article and Applicant's invention, Applicants believe that one skilled in the art would be unable to understand from the Article that its disclosure would anticipate or make obvious the features of Applicant's device. For example, Applicants teach and claim a suction regulator having dividing means between its first and second chambers, with an opening therein. Applicants also teach and claim means for closing the opening in the dividing means. Neither of these features appear to be disclosed in the Article.

To give some context to Atrium's argument, the court reproduces an illustration of the Zuhdi/Kimmel device side by side with the preferred embodiment of the D'Antonio patent.

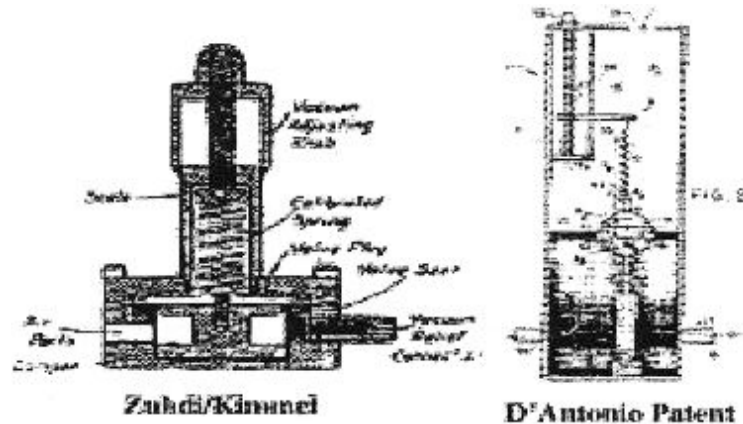

In response, Genzyme contends that the above statement does not evidence any disclaimer of claim coverage. Rather, Genzyme explains that the inventors simply informed the PTO that there were "apparent similarities" in the objectives of the Zuhdi/Kimmel article and their invention, and that the Zuhdi/Kimmel device consists of a valve device whose plug is controlled between its open and closed positions by means of force exerted with an adjustable spring. This statement, Genzyme contends, is merely an expression of the inventors' belief that due to the sparseness of technical information contained in the Zuhdi/Kimmel article, "one skilled in the art would be unable to understand from the Article that its disclosure would anticipate or make obvious the features of [their] device." In other words, they simply argued that the article did not contain sufficient technical detail as to the internal structure of the regulator to enable one skilled in the art to make and use the device in accordance with the article's disclosures. Genzyme's experts concur that it is unclear how the Zuhdi/Kimmel device works and that it is unclear what portion of the Zuhdi/Kimmel device would correspond with the dividing means.

[26] [27] [28] Clearly, when an applicant disclaims coverage of a prior art device, a later claim construction should not give the patentee the benefit of a broad scope of coverage that includes the devices that were expressly disclaimed in order to obtain the patent. However, it is equally clear that not all statements that are made by applicants to the PTO are disclaimers. Rather, a patent claim should only be narrowed based on statements made during prosecution history of the patent where those statements constituted an unmistakable or clear disavowal of coverage. *See* *York Prod.*, 99 F.3d at 1575 ("Unless altering claim language to escape an examiner rejection, a patent applicant only limits claims during prosecution by clearly disavowing claim coverage"); *Pall Corp.*, 259 F.3d at 1393 (explaining that "a narrowing interpretation will be adopted if the accused infringer can demonstrate that the patentee 'defined' the claim as 'excluding' a broader interpretation 'with reasonable clarity and deliberateness' "). Federal Circuit authority is thus clear that the standard for determining if an alleged disclaimer narrows the scope of a claim is whether one skilled in the art would, after evaluating the claim, specification, and prosecution history as a whole, conclude that the statement at issue evidenced a clear and unmistakable surrender of subject matter. *Litton Sys., Inc. v. Honeywell, Inc.*, 140 F.3d 1449, 1458 (Fed.Cir.1998).

Applying that standard here, the court finds that no such narrowing disclaimer occurred. The inventors' statement did not "clearly and unmistakably" surrender any particular subject matter. *See, e.g., IMS Tech., Inc. v. Haas Automation, Inc.*, 206 F.3d 1422, 1439 (Fed.Cir.2000) (finding that "[i]n light of the ambiguity of the patentee's statements [the court could not conclude]... that the patentee clearly disavowed coverage ...."). The inventors stated that certain claimed aspects of their inventions "appeared" to be missing from the Zuhdi article; they made no statement limiting the scope of their invention. Both inventors of the D'Antonio

patent testified at their depositions that they did not understand, from the Zuhdi article, how the disclosed regulator works. At very best, the statements made by the Applicants to the Examiner regarding the Zuhdi/Kimmel device were vague attorney argument that the Zuhdi/Kimmel device was in some way distinct from the claimed invention. But the statements do not indicate that the Applicants were narrowing the scope of the claimed subject matter by advising the Examiner and the public "that a particular structure was not within [their] invention." Ballard, 268 F.3d at 1359. Thus, the court cannot conclude that the D'Antonio inventors clearly and unmistakably disclaimed any specific subject matter relating to "dividing means" by the statement that Atrium relies upon. Therefore, the court will not exclude from the corresponding structure of "dividing means," "cylindrical wall" and "valve seat" structures.

The claimed function of "dividing means" is "to divide said first chamber from said second chamber." The corresponding structure of "dividing means" is a divider or a partition with an opening, and structural equivalents.

### **3. "closing means"**

[29] The term "closing means" is recited in claim 1 and claim 16 of the '531 patent. Claim 1 recites a "first closing means movable between an opening position, to admit air at atmospheric pressure into said second chamber, and closing position for closing said opening to prevent the passage of air at atmospheric pressure into said second chamber." Similarly, claim 16 recites a "closing means for closing said opening." As with the term "dividing means," the parties agree that the term is claimed in means-plus-function form. The claim element uses "means" language, recites a function, and does not recite a structure that performs this function, i.e., closing means is not understood to connote structure that performs the recited function; rather it is stated in purely functional terms. As such, the court must construe both the claimed function and the corresponding structure associated with "closing means" that is disclosed in the specification.

As the functions of the recited closing means opening the opening and closing the opening between the chambers-are clear from the claims themselves, FN21 the parties again focus their dispute the corresponding structure. Genzyme asserts that the corresponding structure is a closing member, such as a ball, hinged door, or other gas port closing means, which can open or close an opening in the suction regulator. Atrium, however, asserts that the only proper corresponding structure is the disclosed spherical ball that fits within the opening in the dividing means, but excludes a valve plug that covers a valve seat. It again bases its proposed construction on the purportedly limited disclosures of the patent specification and on alleged disclaimers of scope made during prosecution.

FN21. Claim 1 and claim 16 actually recite slightly different functions. Claim 1 recites a function of "opening said opening ... and closing said opening...." Claim 16 recites a function of "closing said opening."

The disclosure of the D'Antonio patent that relates to the claimed "closing means" is clear. The patent specification clearly references a seated ball, a hinge, or other gas port closing means, as structures being able to fulfill the closing function. It is also beyond dispute that the preferred embodiment of the '531 patent illustrates a ball valve as the closing member that closes an opening in the divider and moves between an opening and a closing position. The opening provides a gas port for the flow of atmospheric air into the system. The parties disagree, however, as to effect of that disclosure on the claim construction.

Based on the statements in the specification, Genzyme argues that the corresponding structure includes not only the spherical ball, but a hinged door and other gas port closing means. Atrium, however, argues that the applicable principles of means-plus-function claim construction compel its narrower proposed construction.

It is clear from reading the patent that the D'Antonio inventors did want to limit their invention to one

involving only a spherical ball. Rather, the specification expressly states that "a[l]though the foregoing techniques have been described with a seated ball whose position is varied as the pressure differential across it varies, these techniques could be used with other gas port closing means such as hinged doors." '531 patent, col. 7, ll. 39-43. To determine the structure corresponding to a means-plus-function element, the specification must be read as a whole from the viewpoint of one skilled in the art. *Micro Chem.*, 194 F.3d at 1259 (stating that corresponding structures include the most general structures disclosed that satisfy the claimed function).

The issues before the court are whether, in the context of the patent, "other gas port closing means" or "closing member" introduces structure and whether "hinged doors" are described as a structure in the patent. While the most specifically described structure in the preferred embodiment and its corresponding figures is a spherical ball, the patent also illustrates a hinged door that closes a gas port, in the form of flap valve 11, which is mounted on hinge 13 and extends over a port 15. The specification states that "Valve 11 is configured to close and seal port 15 when the pressure in the suction chamber 3 exceeds that in [the] collection chamber." '531 patent, col. 4, ll. 42-43. Moreover, the summary of the invention describes a "closing member in the suction chamber biased to a position for closing the opening with a force according to the desired suction in the chamber." *Id.*, at col. 3, ll. 38-41. In the declarations submitted by Genzyme's experts in the case, they aver that those skilled in the art would understand from these disclosures that the patent discloses that ball valves, flap valves, and other closing members that can close a gas port constitute corresponding structure.

In light of the disclosures of the specification, the court concludes that the "closing means" is not narrowly limited to the spherical ball of the preferred embodiment, but also includes the alternative structure of a hinged door such as a flap valve. The court cannot, however, include as corresponding structure any "other gas port closing means" or a generic "closing member." While the words other gas port closing means are included in the specification, the only specific structural examples of such means in the specification are the spherical ball and a hinged door. Moreover, the corresponding structure of a means-plus-function element cannot be circularly described to include all means for doing the claimed function. Unlike the term "check-valve," which elicits a type of basic structure that is well known in the art, the term "closing member" conveys no well-known structural meaning.FN22 Therefore, the court will only include spherical balls, hinged doors, and their structural equivalents as corresponding structure. Genzyme may assert that other types of valves that are structurally equivalent to spherical balls or hinged doors read onto the "closing means" limitation.

FN22. The dictionary definition of the term "member" is "a structural unit, such as a beam or a wall." But the phrase "closing member," like the claim term "closing means" simply defines a structure in terms of its function. To construe closing means to mean closing member is a circular definition that is meaningless. It is akin to defining the structure of closing means to mean any structure that performs the function of closing.

Atrium next argues, that the construction of "closing means" must be further narrowed based on structures that the patentees disclaimed coverage of during the prosecution of the '531 patent. Specifically, Atrium contends that the inventors disclaimed any interpretation of the closing means limitation that would cover structures other than a ball that fits *within* an opening in the dividing means. It is Atrium's theory that a statement made by the inventors in response to an examination's obviousness rejection based on the Akiyamadevice in view of the Willrath patent constitutes a disclaimer. The purported disclaimer that Atrium points to, however, concerns a rejection of dependent claims that specifically claimed a "closing means" of "generally spherical configuration." The inventors stated:

With respect to claims 4-6 [all of which claim a closing means of a generally spherical configuration], the



examiner has cited Willrath (Fig.2) as teaching it would be obvious to provide the suction regulator of the Akiyama device with a different valve. Applicants respectfully disagree ... [In Figure 2 of the Willrath patent,] the spherical element is not disposed "within" the opening.

The inventors' statement was not directed towards application claim 1, but was instead directed at claims 4-6, all of which claimed a closing means "of generally spherical configuration." Similarly, the statement was not directed at claim 16, which was added to the patent application months after the statement was made. The inventors simply noted that claims 4-6 were directed to a closing means of spherical configuration and a collar with an opening, in which the closing means engaged the collar and the notches on the collar stabilized the closing means, which fit "within" the opening.

As such, Atrium has failed to demonstrate that these statements were intended to disclaim coverage for the broader claims 1 and 16, whose structures include not only spherical balls but hinged doors, and structural equivalents thereof. Therefore, the court will does not agree that the cited statement regarding the Willrath reference mandates that the only corresponding structure for "closing means" in those claims is a spherical ball that fits within an opening. *Pall Corp.*, 259 F.3d at 1393.

However, because a spherical ball is one of the corresponding structures for the "closing means" means-plus-function limitation claimed in claim 1 and 16, the distinction drawn between the Willrath reference and the claimed invention does have the following limited effect. It further limits the corresponding structure of a spherical ball to one that fits within the opening in the dividing means. The patentees clearly stated that where the closing means is embodied by a spherical ball, their invention does not cover any spherical ball; rather, to fall within the scope of their invention, the spherical ball must be disposed within the opening.

Atrium also argues that in distinguishing the Zuhdi/Kimmel article, the inventors disclaimed coverage from the scope of its claims the structure disclosed therein, a valve plug that covers a valve seat. Atrium also raised this argument in connection with the "dividing means" claim limitation. In the above section construing "dividing means," the court found that the statement that Atrium relies upon was not a clear disclaimer of coverage that operates to preclude coverage. Since Atrium again relies on the same statement to argue that "closing means" should be construed to exclude the same structures, the court reaches the same conclusion and will not so limit its construction.

Therefore, the court will construe the corresponding structure of the "closing means" to be a ball that is disposed within the opening of the dividing means, a hinged door, and structural equivalents thereof.

#### **4. "a second compartment having a second chamber communicating with said suction chamber and having an outlet for connecting said second compartment and the suction source"**

[30] Claim 1 recites a system for draining fluids from a portion of the body comprising, among other things, a suction chamber and a suction regulator. The claims require that the "suction chamber [be] communicatable with said collection means, said suction chamber being connectable to a suction source of a suction pressure level." The claims also require the "suction regulator" to include a first and second compartment, each respectively having a first and second chamber, as follows:

a first compartment having a first chamber communicating with the atmosphere;

a second compartment having a second chamber communicating with said suction chamber and having an outlet for connecting with said second compartment and the suction source;

Atrium reads the above language to require two separate connections to an external suction source—the first connection from the suction chamber and the second connection from the second chamber of the suction

regulator. Thus, Atrium proposes that this claim limitation means a second chamber communicating with a suction chamber and having an outlet to the suction source separate from the second chamber's communication with the suction chamber.

In support of its position, Atrium first notes that claim 1 itself requires "a suction chamber being connectable to a suction source" *and* a "suction regulator" including "a second chamber communicating with said suction chamber *and* having an outlet for connecting said second compartment to the suction source." Atrium contends that this demonstrates that two distinct connections are required.

Atrium next seeks support for its proposed construction in the specification of the D'Antonio patent, noting that the patent figures always depict the connections to the suction source as two, separate connections. The first connection to the suction source from the suction chamber is illustrated as reference number 4 in Figure 1 of the patent and is described as "a suction port 4 for interconnecting [suction] chamber 3 with the external vacuum source." The communication between the second chamber and the suction chamber is shown by reference number 77. The second connection to the suction source, from the second chamber of the suction regulator is shown in Figure 2 and described in the patent as "suction port 79." Atrium further argues that although Figures 1, 5, and 8 do not depict a second connector on the second compartment of the suction regulator, those figures do not show the entire device, because the very portion of the figures (the bottom) where the second connection would be located-according to the claim and to Figure 2-is cut-off.

Last, Atrium argues that the prosecution history supports its proposed construction. In that regard, Atrium notes that the limitation of "an outlet for connecting said second compartment and the suction source" was added by an amendment in an attempt to distinguish the claims from the prior art. Atrium contends that if the second chamber's "outlet" limitation is satisfied merely by the second chamber's communication with the suction regulator through passage 77, as Genzyme argues, the amendment would have been superfluous.

Genzyme, in opposition, argues that no claim limitation in claim 1 requires the existence of two separate and external connections to the suction source. According to Genzyme, the "outlet for connecting the second compartment and the suction source," is the same structural element as the "second compartment's communication with the suction chamber." Genzyme and Atrium agree that the specification shows that the suction chamber is connectable to a suction source through port 4. However, Genzyme contends that the claimed "outlet for connecting said second compartment and the suction source" is passage 77, as shown in Figure 1-not suction port 79, shown in Figure 2. Genzyme thus argues that the "outlet for connecting the second compartment and the suction source" can be satisfied by a passageway running between the second compartment of the suction regulator and the suction chamber and a suction chamber that has an connection to the suction source.FN23 In other words, an independent and direct connection port from the second chamber of the suction regulator to the suction source is not required.

FN23. Outlet is defined as a "means for exit of escape; opening; vent." Websters Third New International Dictionary (1981 ed.).

Genzyme argues that Atrium's use of Figures 1 and 2 to support its proposed construction is erroneous. Atrium contends that Figure 1 illustrates a first connection to the suction source through suction port 4, and that Figure 2 illustrates a second connection to the suction source through port 79. Genzyme notes that, according to the patent specification, the regulator depicted in Figure 2 is "slightly modified" from the regulator of Figure 1-the regulator shown in Figure 2 is an independent suction regulator unit, which would have to be modified to be inserted into a system like Figure 1. Only one connection to suction source is required in either case. Where the invention is depicted as an entire system, including the suction regulator, the connection to suction source is shown to be on the suction chamber. Where the invention is depicted as a stand-alone suction regulator, the connection to suction source is shown to be on the regulator. Thus

Figure 2, shows an independent unit that has two separate tubes-outlets 77 and 79. Outlet 77 communicates with the suction chamber, while outlet 79 connects to the suction source. However, looking only at Figure 1, no independent connection from the second chamber of the suction regulator to the suction source is depicted. Genzyme submits that none is required.

Genzyme further bolsters its argument by pointing out that no one figure in the D'Antonio patent shows two external and separate connections to a vacuum source. Therefore, it argues, Atriums proposed construction must be incorrect, because it would exclude the preferred embodiment of the invention and the only embodiments illustrated in the patent. *See Vitronics Corp.*, 90 F.3d at 1583 (a claim construction that excludes an invention's disclosed embodiments is "rarely, if ever, correct and would require highly persuasive evidentiary support."). It also contends that Atrium's contention that the portion of the Figure that "would contain" port 79 are cut-off is belied by the drawings themselves and by patent drafting rules, which require that patent figures show all features of the invention. *See C.F.R. s. 1.83.*

Claim 1 requires a suction chamber that is "connectable to a suction source" and also requires a suction regulator, containing a second chamber of a second compartment that communicates with the suction chamber and has an outlet for connecting the second compartment to a suction source. At first glance, it seems that Atrium might be correct that the claim language mandates that there are two separate connections to the suction source. The claim language, however, is ambiguous as to whether two separate structural items are required. To resolve this ambiguity the court turns to the specification. It is apparent, after review of the specification, that nothing in the specification suggests that the "communicating" and "having an outlet for connecting ... to said suction source" limitations of the second compartment of the suction regulator require distinct structures to satisfy the claims. Accordingly, for the reasons further explained below, the court concludes that only one connection to the suction source is required, and that connection may be from the suction chamber.

The specification and its figures offer some guidance in resolving the ambiguous claim language. First, the specification does not mention that the claimed invention in any way relates to having two connections to a suction chamber. Nor does the specification describe or show any embodiment with two independent suction connections. In each embodiment described, the specification describes only one connection port to a suction source. Moreover, requiring two separate and direct connections to the suction source—one from the suction chamber and one from the second chamber of the suction regulator—would make little sense. Because the suction chamber and the second chamber of the suction regulator are maintained at the same pressure by virtue of pathway 77, only a single connection is required to apply suction to the patient.FN24 For these reasons, one skilled in the art, reading the disclosure of the '531 patent would not conclude that two separate connections to suction source are required.FN25

FN24. This is supported by an earlier version of the specification, which explained that "Port 79 [the connection to the suction source depicted in Fig. 2] could be located in some other wall defining suction chamber 3."

FN25. Indeed, all of the experts in the case agree that they have never seen, nor would they ever expect to see a device with two distinct connections to an external source of suction; such an arrangement would be superfluous because the suction chamber and second compartment of the suction regulator are connected and therefore are at the same pressure level.

Second, none of the figures that purport to illustrate the claimed invention show a second connection to a suction source emanating from the suction regulator. Figure 1 shows a connection, labeled  $P_s$ , at the top of the suction chamber. No such connection is shown on the suction regulator. This suggests that the

"communicating" and "having an outlet for connecting ... to said suction source" limitations of the second compartment of the suction regulator may both be fulfilled by pathway 77. In other words, pathway 77 is the outlet that connects the second compartment, indirectly, to the suction source. This is more clearly depicted in Figure 5, reproduced below, which shows an arrow from the suction regulator to the connection port to the suction source at the top of the suction chamber, labeled reference number 4.

\*334

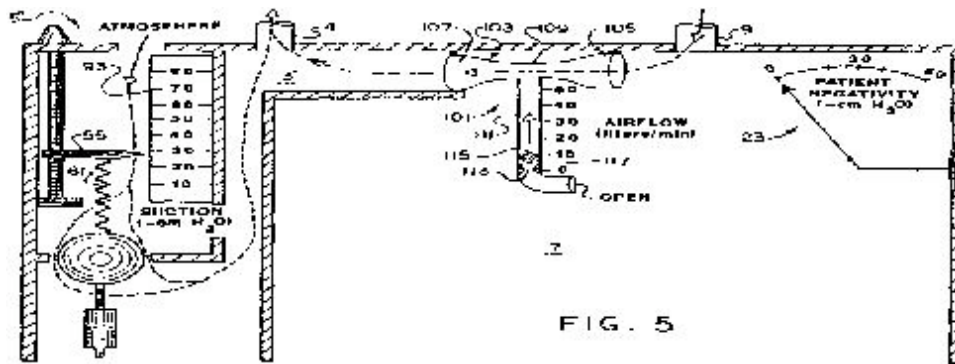

Atrium's arguments do not compel a contrary construction. Atrium primarily relies on Figure 2, depicted below, to support its contention that a second connection to the suction source independent of the pathway that connects the suction regulator and the suction chamber is required. Figure 2 shows one connection to the suction source (the port labeled 77, on the lower right side), which satisfies the "communicating with" limitation, and also shows a connection port, which may be connected to a suction source (the port labeled 79, on the lower left side), which satisfies the "having an outlet for connecting ... to said suction source." Atrium reasons that viewing Figure 2 in combination with Figure 1, which itself shows a connection port to a suction source in the suction chamber, compels the conclusion that two separate connections are required.FN26

FN26. Atrium also argues that reliance on Figures 1 or 5 would be erroneous, because they do not show the entire length of the claimed device. But a review of those figures confirms that this is not the case. The figures are complete.

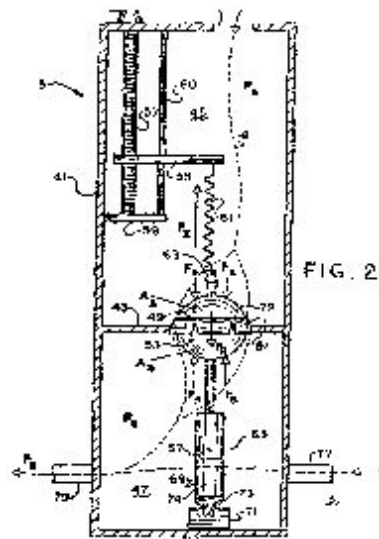

As Genzyme points out, however, the flaw in Atrium's reasoning is that combining Figure 1 and Figure 2 is improper, because they illustrate different inventions, or at the very least they illustrate different and independent embodiments of the invention. Figure 1 "is a schematic diagram of a chest drainage system according to the invention." Figure 2, however is a schematic diagram of an independent suction regulator. The specification explains that "[t]he suction regulator in Fig. 2 is shown as an independent unit which would be modified for a particular application such as incorporation in the system of Fig. 1." Therefore, it is not surprising that Figure 2 provides for its own direct connection to a suction source.

Atrium challenges the conclusion that Figure 1 and Figure 2 illustrate different inventions by referring to the following language from the specification. After distinguishing between "Suction regulator 5 ... in Fig. 1" and "Suction regulator 5' [modified and shown in further detail] in Fig. 2," the specification describes suction regulator 5. At the end of its description it states that "lower chamber 47 includes an entrance port 77 ... and is connected to the hospital suction source through a port 79 at pressure  $P_S$ ." '531 patent, col. 5, II. 41-45. Based on this language, Atrium asserts the regulators shown in Fig. 1 and Fig. 2 are not different suction regulators 5 and 5', but rather that both refer to the same suction regulator 5. Combining both figures, Atrium asserts that the system including suction regulator 5 requires two connections to the suction source—one on the second compartment of the suction regulator and one on the suction chamber.

While this portion of the specification does create some ambiguity, in light of the specification as a whole, the court does not agree with Atrium that it compels a construction that requires two separate connections. A subsequent paragraph of the specification states that "the operation of suction regulator 5' as depicted in Fig. 2 will now be explained." Id., col. 6, II. 9-10. This again confirms that Fig. 2 depicts the stand-alone suction regulator that is distinct from the in-system suction regulator shown in Fig. 1. It logically follows that the only reason that Fig. 2 shows an connection from the suction regulator directly to the source of suction is because it is a stand-alone device. In fact, the patent specification consistently draws a distinction between when the suction regulator is used as a stand-alone device and when it is used as part of a system. For example, the specification notes that "suction regulators 5' and 5" can be "incorporated in systems such as that in Fig. 1, but ... [can] also ... be incorporated in other chest drainage systems..." Id., col. 7, II. 18-20. Moreover, latter portions of the specification confirm that the specification refers to "suction regulator 5" and depicts it *without* any independent direct connection to suction source when discussing how the stand-alone suction regulator unit can be incorporated into a system. For example, the specification notes that:

[a] chest drainage system 201 incorporating [stand-alone] suction regulator 5 used with suction measuring

device 6 of Fig. 1 ... is shown in Fig. 8. To operate system 201, port 4 [in the suction chamber] is connected to the suction source.

Id., col. 8, II. 63-68 & Fig. 8. This arrangement is shown in Fig. 8. Importantly, Fig. 8, like Fig. 1-and like all the figures of the patent that show the suction regulator incorporated into a system that includes a suction chamber does not show the suction regulator as having its own port 79 to connect to suction source; rather, the suction source is connected only through port 4 in the suction chamber. Throughout the specification, when the suction regulator is discussed and illustrated as part of a system, and connected with a suction chamber that has its own connection to a suction source, no second independent connection to suction source is discussed or required. Otherwise, it connects indirectly to the source of suction through the connection to suction source in the suction chamber. Thus, on the whole, the specification and figures confirm that the claimed suction regulator only requires its own connection to a source of suction when it is not a part of "a system for draining fluids." FN27

FN27. The specification, at times, alludes to a stand-alone suction regulator, as shown in Fig. 2, built as contemplated by the invention. Claim 1, however, discloses a "system for draining fluids" that includes the suction regulator built according to the invention.

In sum, a connection to suction source is clearly required, but depending on whether the specification is referring to the system or the stand-alone regulator, it may be either on the suction regulator itself or on the suction chamber; neither the specification nor the claim language requires that both have separate direct connections to suction source. Rather, it is apparent from the specification (including the figures) that when the suction regulator is used within the claimed "system for draining fluids," the second compartment's "outlet for connecting ... [to] the suction source" runs through path 77 and into suction chamber 3, which connects to the suction source through port 4.

The prosecution history also fails to compel the court to adopt Atrium's proposed construction. The court can find no support for Atrium's contention that the patentee's amended their patent application to add the "outlet for connecting said second compartment and the suction source" limitation, for the purpose of distinguishing the claims from the prior art. Rather, the inventors simply explained that they were amending the claim "to improve its form and to positively recite the preferential draw feature...." The inventors did not state that the addition of this language was done to distinguish prior art devices that had only one connection to suction source. Indeed, not once in the prosecution history of the '531 patent is the limitation relating to source of suction ever mentioned.

Moreover, both before and after the amendment, the Patent Examiner applied as prior art against claim 1 systems that included a single external connection of suction to the chest drainage device. In addition, the inventors never argued that such prior art did not meet the limitations at issue, because they lacked a second and separate external connection to a suction source. Not once do the inventors assert that their invention is distinct from the prior art devices because it requires two separate connections to sources of suction.FN28 This demonstrates that neither the patentees nor the Examiner considered a second and separate external connection to be required by claim 1, and provides further support for Genzyme's proposed construction. Thus, no objective reader of the prosecution history could conclude that this language was added in order to limit the invention to one having two distinct connections to suction sources in order to draw a distinction over the prior art.

FN28. Such a distinction would have been a powerful and simple one to make as no prior art device (and no current device for that matter) contains two separate external connections to suction source.

Read in light of the patent's disclosures, it is apparent that the claim language was drafted in a manner that is broad enough to encompass the embodiments of both Figures 1 and 2. The claim simply does not require two separate external connections to a source of suction. Rather, it mandates that the suction source and suction regulator communicate (via pathway 77) and provides that either may be directly connected to a suction source. By virtue of the connection between them, so long as either the suction regulator or the suction chamber has a connection to a source of suction, both the "suction chamber being connectable to a suction source" and "second compartment [of the suction regulator] ... having an outlet for connecting said second compartment and the suction source" limitations may be satisfied.

Therefore, the court will not construe the claims to require that the accused device contain two separate and independent connections to a suction source.

## **5. "biasing means" and "preferentially apply suction"**

### **a. "biasing means"**

[31] Claim 1 of the '531 patent discloses a "biasing means for moving said closing means to the closed position when the pressure in said suction chamber exceeds said desired pressure to preferentially apply said suction pressure level to said suction chamber ...." Claim 16 claims a "means for applying a force to said closing means to move said closing means to a predetermined position." Claim 18, which depends from claim 16, recites "The invention according to claim 16 wherein ... said force applying means comprises biasing means for biasing said opening means to said closing position."

There is no dispute that the above-quoted means language should be interpreted in accordance with s. 112, para. 6. The parties, however, dispute the construction of the claimed function, what structure corresponds to that function, and whether that structure is indefinite, under s. 112, para. 2.

Atrium submits that the function of the "biasing means" is "to preferentially apply suction to the patient." Atrium argues that the applicants defined this function during prosecution by stating that the claimed device "preferentially draw[s] from the patient to ensure evacuation of the lung cavity," and that "air is preferentially and exclusively drawn from the patient until the predetermined pressure conditions are met."

Genzyme, in opposition, asserts that the functions for the claimed biasing means of claims 1, 16, and 18 are expressly set forth in the language of each claim. For claim 1, the recited function for "biasing means" is "moving said closing means to the closed position." For claim 16, the recited function for "means" is "applying a force to said closing means to move said closing means to a predetermined position." For claim 18, the recited function for "biasing means" is "biasing said opening means to said closing position."

The court agrees with Genzyme that the functions set forth in claims 1, 16, and 18 are those expressly stated in the claims. Therefore, the court will adopt Genzyme's construction of the function for the "biasing means." Genzyme's construction of the corresponding function is in accord with the plain meaning of the claims and is consistent with Atrium's own expert's position that "the function of the biasing means is to urge the closing means ... into a closed position." Furthermore, it would strain the principles of claim construction to find that the phrase "preferentially apply," is the function of claims 16 and 18 when that language does not appear in those claims. This is not inconsistent with the statements in the prosecution history cited by Atrium. Rather, the court understands the "preferentially apply" language that Atrium cites as being functional in claim 1, as referring to the result that occurs when the biasing means operates-i.e., moves the closing means to a closed position-not the function of the biasing means.

Atrium's indefiniteness position follows from its contention that the function of the biasing means is "to preferentially draw." The court, however, has construed the function of the biasing means to be moving the

closing means to a closed or predetermined position. The corresponding structure disclosed in the '531 patent that performs this function is a spring. The specification identified a "spring 61" that biases the closing means (a ball, in the preferred embodiment) into a closed position. This aspect of the invention is illustrated in Figures 1, 2, 4, 5, 8, and 12.

#### **b. "preferentially apply"**

[32] As stated above, the term "preferentially apply" appears in claim 1 of the '531 patent as follows:

biasing means for moving said closing means to the closed position when the pressure in said suction chamber exceeds said desired pressure *to preferentially apply* said suction pressure level to said suction chamber when the pressure in said suction chamber is greater than said desired pressure, and said closing means moving to said open position when the pressure in said suction chamber is less than said desired pressure.

This limitation was added to claim 1 during the prosecution of the application, through preliminary amendment, to describe how air/fluid is drawn from the patient in their invention until a predetermined condition occurs. As the patentees explained: "In the present invention defined in claim 1 ... suction is applied to the patient's lung without the admission of any atmospheric air through the suction regulator to preferentially draw air from the lung, until a predetermined suction level occurs in the regulator. It is only when the foregoing suction or low pressure occurs that atmospheric air is admitted into the system."

It is apparent that this concept is described in the specification as follows. When the suction chamber is connected to a source of suction, air from the patient's lung cavity enters the system through an inlet port. Atmospheric air is introduced into the suction chamber by the suction regulator only when the suction pressure in the system reaches a predetermined level as set by a spring, which drives the closing means of the suction regulator. However, until this condition is met, air is drawn from the patient only. Thus, air is drawn in a "preferential" nature from the patient first.

Atrium contends that the definition of "preferentially apply" requires the device to preferentially and exclusively draw air from the patient's chest, rather than from the atmosphere, until all of the air has been withdrawn from the patient and only then draws air from the atmosphere. Genzyme argues that this definition goes too far in requiring that atmospheric air may only enter the system upon the evacuation of *all* air from the patient. According to Genzyme, the court should simply adopt the definition set forth by the patentees in the prosecution history without adding further limitations.

The court agrees with Genzyme. As the patentee's expressly defined the preferential draw feature of the invention in the prosecution history, the court will adopt that definition as its construction of that claim term. "Preferentially apply" refers to "applying suction and thus first drawing air from the patient's lung cavity, without the admission of any atmospheric air through the suction regulator until a predetermined suction level occurs in the suction regulator."

#### **6. "damping means"**

[33] Claim 16 of the '531 patent recites "damping means for damping the force applied by said closing means." As with a number of the previously construed terms, the parties agree that this term is claimed in means-plus-function form. It uses "means" language, recites the function of damping a force, and fails to recite structure that performs this function, i.e., damping means is not understood to connote structure that performs the recited function. The claimed function is simply "damping the force applied by said closing means."



The parties dispute the corresponding structure. Genzyme submits that the corresponding structure is a damping device, such as a dash pot (and structural equivalents), for damping the applied force in the suction regulator. Genzyme argues that the specification supports its proposed definition. In the summary of invention section, the patent explains that the invention is directed to a "damping device for dampening the resultant force on the closing member." Genzyme then points out that the preferred embodiment section identifies one example of a damping device in the form of a dash pot: "a dash pot 65 composed of a piston 67 attached to ball 53 and a cylinder 69 receiving the piston in sliding engagement and mounted on a support block 71 by means of pivot 73." Nonetheless, Genzyme argues, the broader disclosure of "damping device" suffices to disclose corresponding structure, and the construction of the claim should not be limited to the example given as the preferred embodiment. Last, Genzyme argues that its construction is supported by the doctrine of claim differentiation. Claim 17 recites: "[t]he invention of claim 16 wherein said damping means comprises a dash pot." Under the doctrine of claim differentiation, the "damping means" disclosed in claim 16 must have a broader meaning than simply a "dash pot," or else claim 17 would be rendered superfluous. *See Comark Comms., Inc. v. Harris Corp.*, 156 F.3d 1182, 1187 (Fed.Cir.1998) ("While we recognize that the doctrine of claim differentiation is not a hard and fast rule of construction, it does create a presumption that each claim in a patent has a different scope.").

Atrium, on the other hand, asserts that the corresponding structure is limited to the disclosed dash pot structure of a piston within a cylinder that damps forces by restricting air flow in the cylinder. It argues that Genzyme's assertion that "damping means" covers *any* device capable of performing the function of damping the movement of the closing member, eviscerates the requirements of s. 112, para. 6. Atrium contends that the particular dash pot alluded to above is the only structure disclosed in the D'Antonio patent for performing the damping function. As for the disclosure of "damping device" in the summary of invention, Atrium argues that, just as the phrase "damping means" connotes no particular structure, neither does the phrase "damping device." The term "device" is simply a generic place holder, not a connotation of any particular structure. Last, to rebut Genzyme's claim differentiation argument, Atrium directs the court to Federal Circuit authority that establishes that the doctrine of claim differentiation is of highly limited value when construing means-plus-function claims. *See, e.g., Laitram Corp. v. Rexnord, Inc.*, 939 F.2d 1533, 1538 (Fed.Cir.1991) ("[a] means-plus-function limitation is not made open-ended by the presence of another claim specifically claiming the disclosed structure which underlies the means clause.").

The court finds that the corresponding structure of the "damping means" is limited to the disclosed dash pot, because a "damping device" does not connote any structure above and beyond a "damping means." Therefore, a dash pot is the only structure disclosed that corresponds to the claimed function, and the scope of the claim is limited to a dash pot and its structural equivalents. As plaintiffs themselves point out, the Dictionary of Mechanical Engineering defines a dash pot as "a damping device consisting of a piston and a cylinder whose relative motion is opposed by the fluid friction of a liquid or of air." This definition itself demonstrates the obvious—a damping device is a generalized all encompassing term, while a dash pot connotes a specific structure. Moreover, where, as here the disclosure of corresponding structure is limited to a single disclosure, the doctrine of claim differentiation cannot itself broaden the scope of that claim. *Id.*

Atrium further argues that structures which damp forces by the purposeful use of friction between the piston and cylinder wall should also be excluded. In the D'Antonio patent, as the piston moves downward, air within the piston chamber is compressed and slowly escapes between the piston and the cylinder, thus slowing the rate of movement of the spherical ball closing means. The specification points out that it is important that the dash-pot structure be designed to minimize friction or drag between the piston and the cylinder wall. While this argument may be relevant for purposes of determining equivalent structures or a doctrine of equivalents analysis, given that its above construction expressly references the specific disclosure of the patent, the court sees no need to further limit the structures that may constitute "damping means" as a matter of claim construction.FN29

FN29. In making this determination, the court notes that nowhere in the specification does the patent exclude the use of frictional damping. In addition, the claimed function of the "damping means" is "damping" not "frictionless damping." Therefore, the corresponding structures are those that perform the function of damping. The corresponding structures are not required to perform the function of frictionless damping. *See Micro Chem.*, 194 F.3d at 1258. These considerations counsel against further limiting the construction of damping means.

Therefore, the court construes the term "damping means" as follows: (i) the corresponding function is "damping the force applied by the closing means;" (ii) the corresponding structure is the disclosed "dash pot" structure of a piston within a cylinder, and structural equivalents thereof.

## V. Summary of Court's Claim Construction of Disputed Terms

For the reasons set forth above, the court adopts the following as its claim construction of the disputed terms of the patents-in-suit.

### A. The Elliot Patents

"one-way valve" and "one-way waterless valve means"	This is not means-plus-function limitation. The terms mean "a type of valve, also known as a check valve, that allows the flow of fluid in one direction but prevents flow in the reverse direction."	lines
"means defining a flow path between the inlet tube and said one-way waterless valve" and "flow path"	This is not a means-plus-function limitation. The terms mean a path along which air flows between the distinct points.	
"water seal"	The term means a fluid filled structure that allows air to escape from the patient but prevents the back flow of air to the patient.	
"air leak detector," "air leak detector means," "U-shaped path," "U-tube," and "combination negative pressure indicator and air leak detector"	These terms are constrained to mean an air leak detector or U-tube that does not act as a water or fluid seal.	

### B. The D'Antonio Patent

"suction chamber"	This term means "a chamber of regulated pressure connectable to a source of suction and a suction regulator, and which applies suction to a collection chamber."	lines
"dividing means"	This is a means-plus-function element. The claimed function is "to divide said first chamber from said second chamber." The corresponding structure is a divider or partition with an opening, and structural equivalents thereof.	lines
"closing means"	This is a means-plus-function element. The claimed functions are "opening said opening and closing said opening" (claim 1) and "closing said opening" (claim 16). The corresponding structure is a ball that is disposed within the opening in the dividing means, or a hinged door, and structural equivalents thereof.	
"suction chamber being connectable to a suction source of a suction pressure level" and "second compartment [of the suction regulator]... having an outlet for	These limitations together do not require two separate and independent connections to suction. Rather, the latter may be satisfied by a pathway between second compartment of the suction regulator and the suction chamber, which in turn is connectable to a source of suction.	

connecting said second compartment and the suction source"	
"damping means"	This is a means-plus-function element. The claimed function is "damping the force applied by said closing means." The corresponding structure is "the disclosed dash pot structure of a piston within a cylinder" and structural equivalents thereof.
"biasing means"	This is a means-plus-function element. The claimed function for the biasing means of claims 1 and 16 is "moving the closing means to a closed position." The claimed function for the biasing means of claim 16 is "moving the closing means to a predetermined position." The corresponding structure of the biasing means for all three claims is a spring and its structural equivalents.
"to preferentially apply"	This term means "applying suction and thus first drawing air from the patient's lung cavity, without the admission of any atmospheric air through the suction regulator, until a predetermined suction level occurs in the suction regulator."

Produced by Sans Paper, LLC.