

X B-25

March 9, 1965

P. E. MAYES ETAL

Re. 25,740

LOG PERIODIC BACKWARD WAVE ANTENNA ARRAY

Original Filed Sept. 30, 1960

2 Sheets-Sheet 1

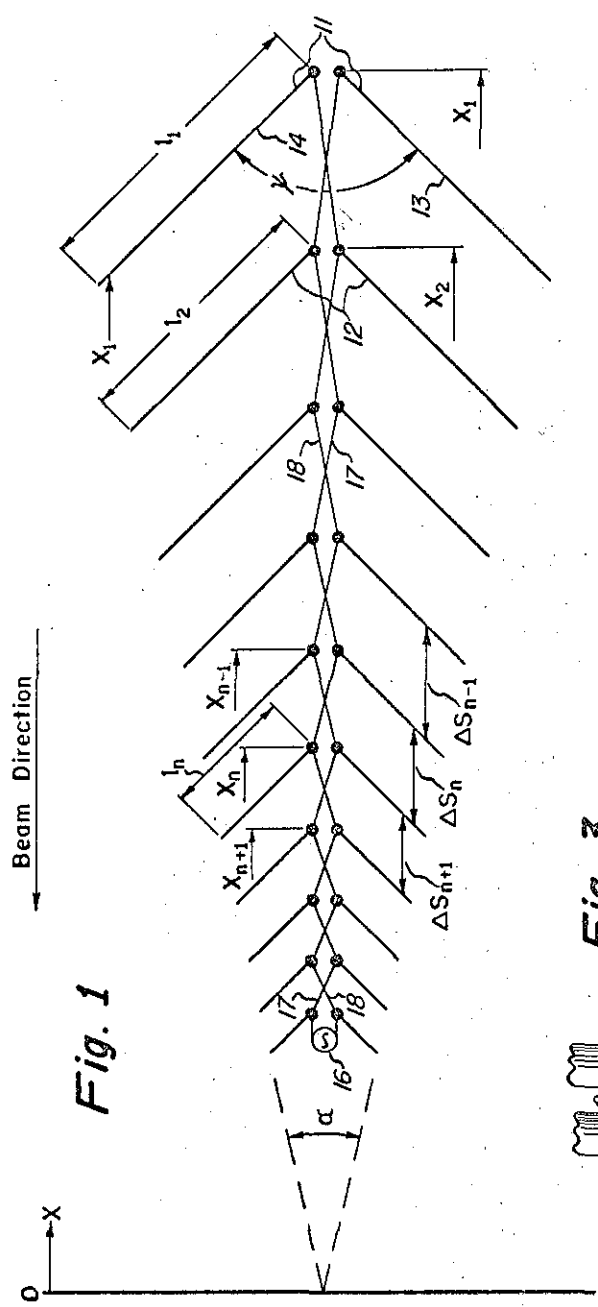
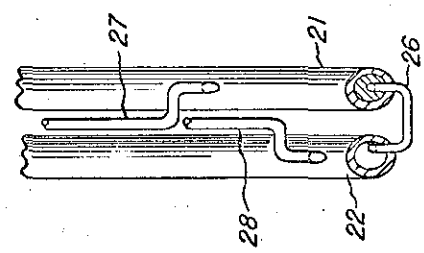

Fig. 1

Fig. 3



INVENTORS:
 Paul E. Mayes
 Robert L. Garrel
 BY
 Merriam, Smith & Marshall
 ATTORNEYS

XB-26

Sept. 22, 1964

R. L. CARREL ETAL

3,150,376

MULTI-BAND LOG PERIODIC ANTENNA

Filed April 3, 1964

2 Sheets-Sheet 1

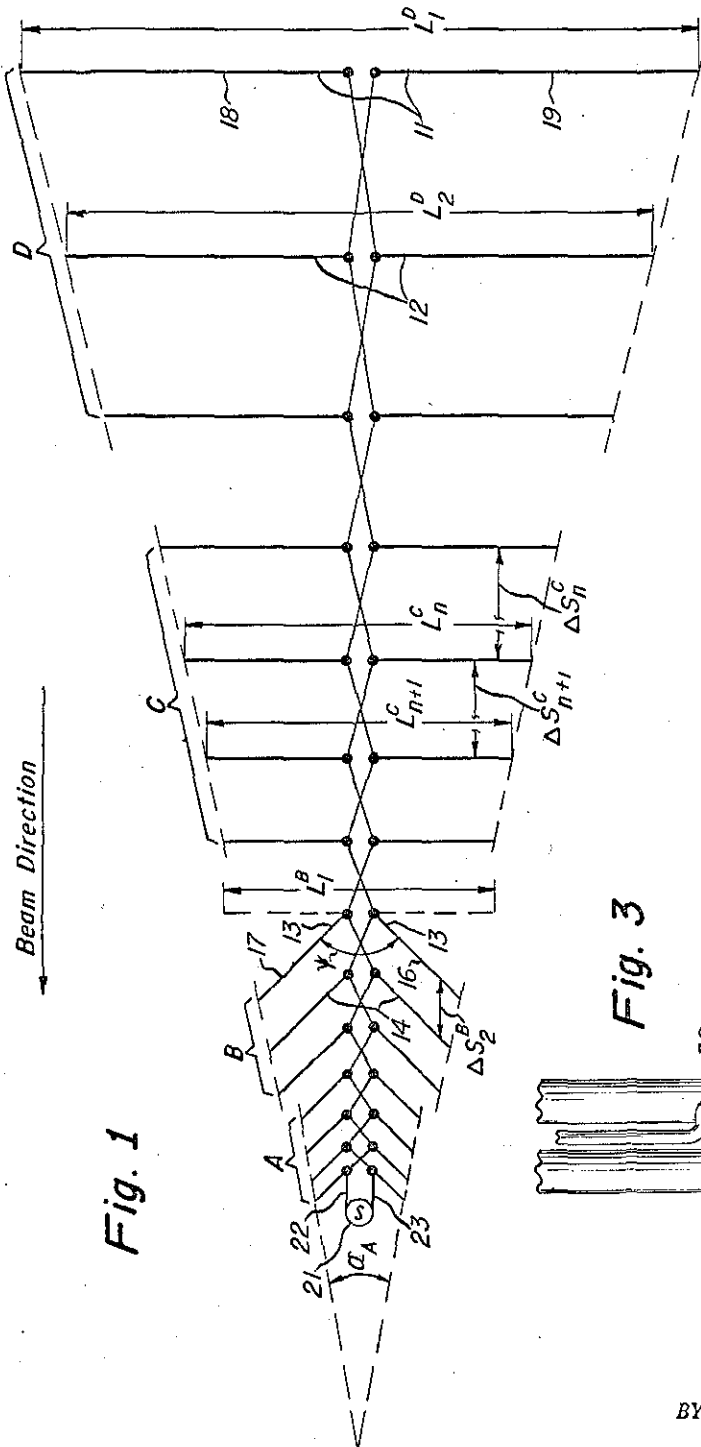

Fig. 1

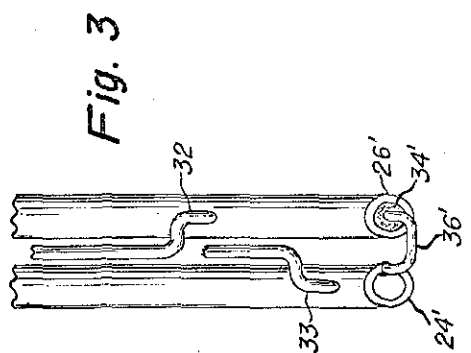
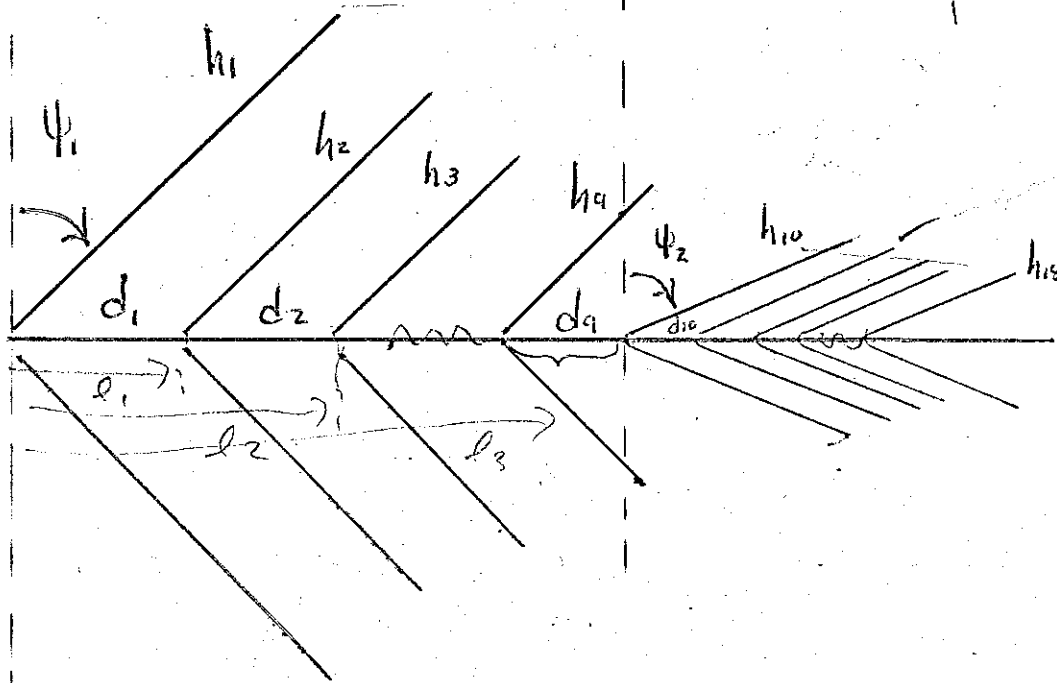

Fig. 3

INVENTORS:
 Robert L. Carrel
 Paul E. Mayes
 BY
 Merriam, Smith & Marshall
 ATTORNEYS

XB27



- $l_1 - 12 \frac{3}{4}$
- $l_2 - 24 \frac{21}{32}$
- $l_3 - 35 \frac{3}{4}$
- $l_4 - 46 \frac{3}{32}$
- $l_5 - 55 \frac{3}{4}$
- $l_6 - 64 \frac{23}{32}$
- $l_7 - 73 \frac{3}{32}$
- $l_8 - 80 \frac{7}{8}$
- $l_9 - 88 \frac{1}{8}$
- $l_{10} - 91 \frac{7}{8}$
- $l_{11} - 95 \frac{1}{2}$
- $l_{12} - 99$
- $l_{13} - 102 \frac{13}{32}$
- $l_{14} - 105 \frac{21}{32}$
- $l_{15} - 108 \frac{13}{16}$
- $l_{16} - 111 \frac{7}{8}$
- $l_{17} - 114 \frac{27}{32}$

DIMENSIONS		
ELEMENT LENGTH	SPACINGS	
	$h_1 = 59.0''$	$d_1 = 12.75$
$h_2 = 55.0$	$d_2 = 11.9$	
$h_3 = 51.26$	$d_3 = 11.1$	
$h_4 = 47.77$	$d_4 = 10.35$	
$h_5 = 44.51$	$d_5 = 9.65$	
$h_6 = 41.51$	$d_6 = 8.98$	
$h_7 = 38.72$	$d_7 = 8.37$	
$h_8 = 36.1$	$d_8 = 7.79$	
$h_9 = 33.5$	$d_9 = 7.24$	
$h_{10} = 33.5$	$d_{10} = 3.752$	
$h_{11} = 32.39$	$d_{11} = 3.625$	
$h_{12} = 31.3$	$d_{12} = 3.51$	
$h_{13} = 30.25$	$d_{13} = 3.39$	
$h_{14} = 29.22$	$d_{14} = 3.28$	
$h_{15} = 28.28$	$d_{15} = 3.17$	
$h_{16} = 27.35$	$d_{16} = 3.07$	
$h_{17} = 26.42$	$d_{17} = 2.96$	
$h_{18} = 25.57$		

$h_{11} = h_{10} T_2$
 $h_{12} = h_{11} T_2$
 $d_{10} = 4 \sigma_2 h_{10}$
 $d_{11} = T d_{10}$
 $h_2 = h_1 T_1$
 $d_2 = d_1 T_1$
 $h_{10} = 33.5$
 $h_{18} = 25.5$

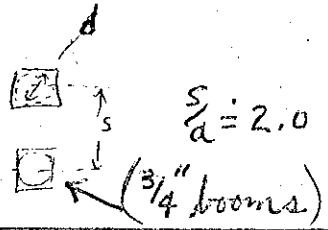

MATERIAL NOTES
 $T_1 = .934$, $\sigma_1 = .054$, $N_1 = 9$, $\psi_1 = 40^\circ$
 $T_2 = .967$, $\sigma_2 = .028$, $N_2 = 9$, $\psi_2 = 55^\circ$
 $4h_1\sigma_1 = d_1$ } σ_1 for $d_1 \rightarrow d_9$ } ψ_1 for $h_1 \rightarrow h_9$, .215 wire for $h_{10} \rightarrow h_{18}$
 $4h_{10}\sigma_2 = d_{10}$ } σ_2 for $d_{10} \rightarrow d_{17}$ } ψ_2 for $h_{10} \rightarrow h_{18}$, 3/8" tube for $h_1 \rightarrow h_9$

TEMPORARY SKETCH			
MODEL VU LPV-18 L			
DATE 11/18/63	APPROVED <i>EQ</i>		
DRAWN <i>EQ</i> 11/18/63	SCALE		
JFD ELECTRONICS CORP. ANTENNA LABORATORY			

X B 28 \leftarrow

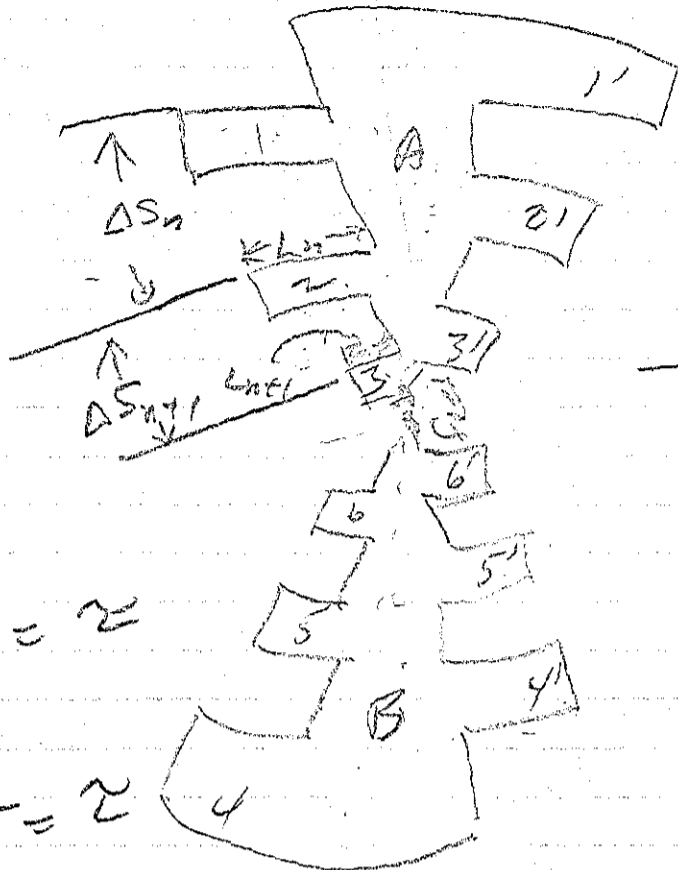

$$\frac{L_{net}}{L_n} = \approx$$

$$\frac{\Delta S_{net}}{\Delta S_n} = \approx$$

Fig. 1

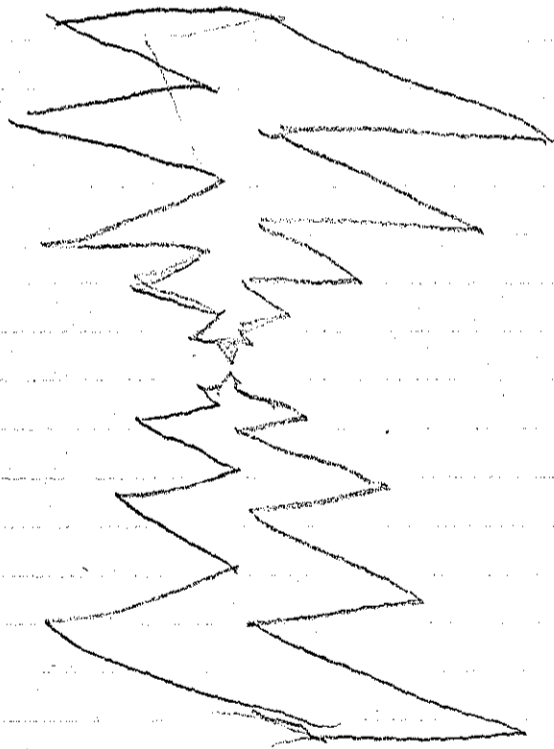
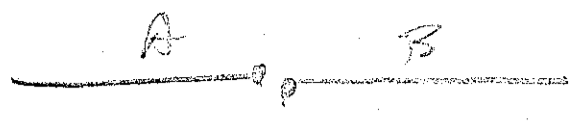
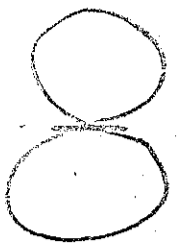
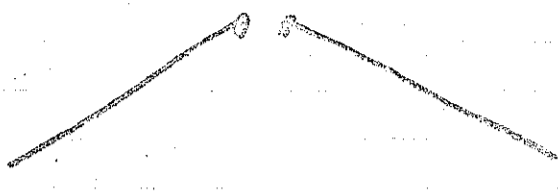
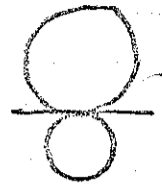

Fig. 2

10/2/22



(a)



(b)

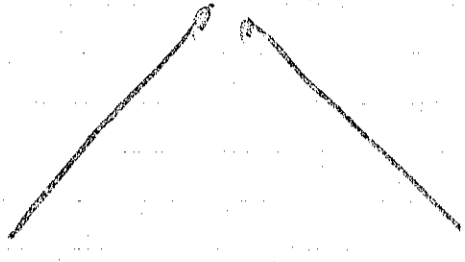

(c)

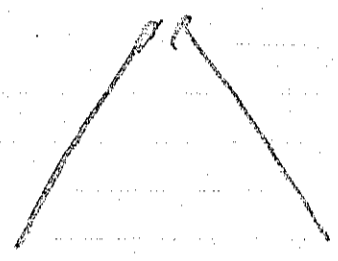

(d)



(e)

AT THE MOMENT OF TRUTH -- THE PICTURE IS THE PROOF!

THE JFD LOG-PERIODIC LPV IS BEST FOR COLOR, BLACK AND WHITE TV, AND FM STEREO.

X B 30 
Model LPV11 (illustrated)

D Ex 32

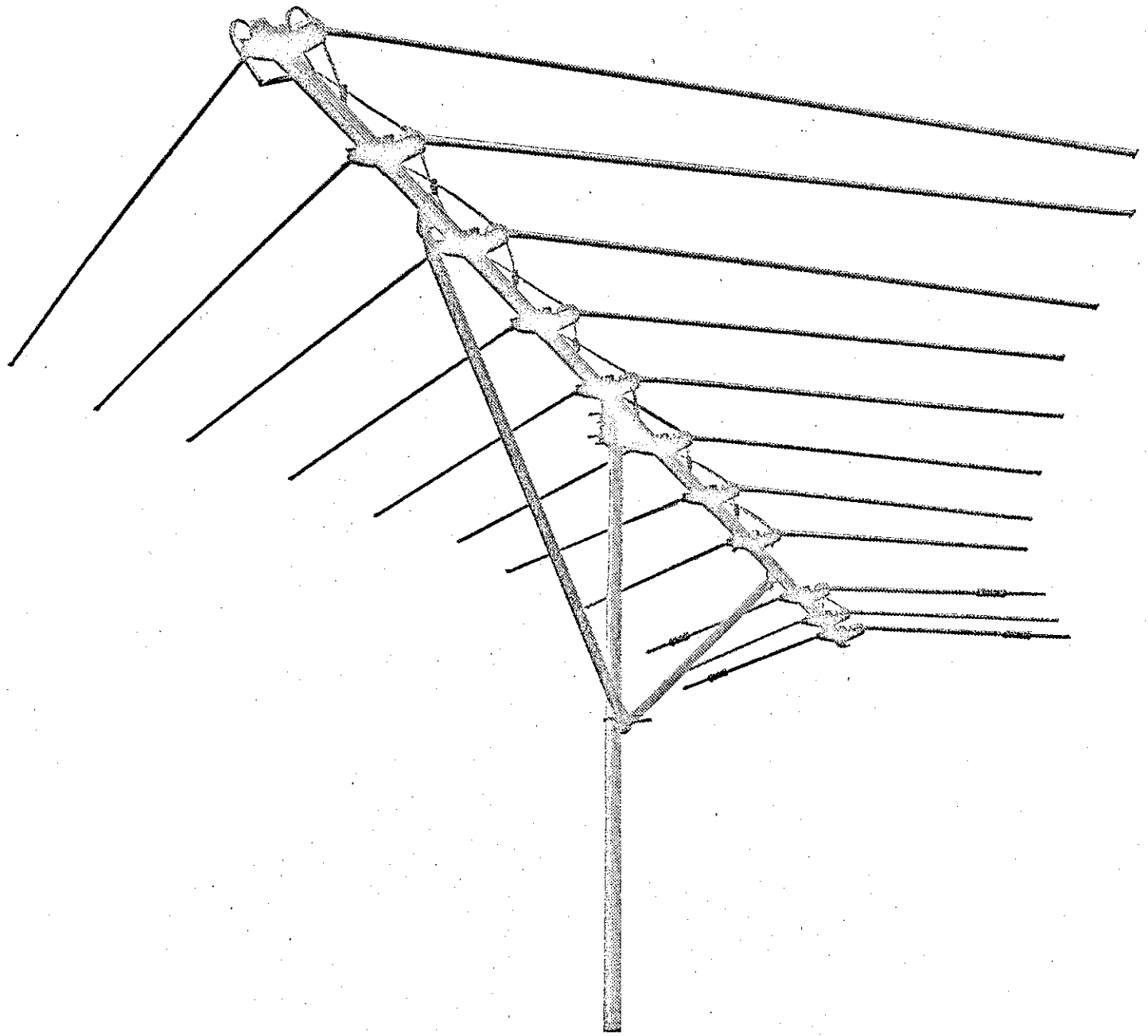

$\frac{L(n+1)}{L_n} = \tau$ - the reason why the JFD LOG-PERIODIC LPV has obsoleted all other TV antenna designs overnight!

Performance has made the LPV first in antenna sales—not claims or words. JFD will gladly abide by that moment of truth that proves the true caliber of any antenna's performance- THE PICTURE IS THE PROOF!

AT THE MOMENT OF TRUTH — THE PICTURE IS THE PROOF!

THE JFD LOG PERIODIC LPV IS BEST FOR COLOR, BLACK AND WHITE TV, AND FM STEREO.

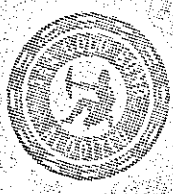
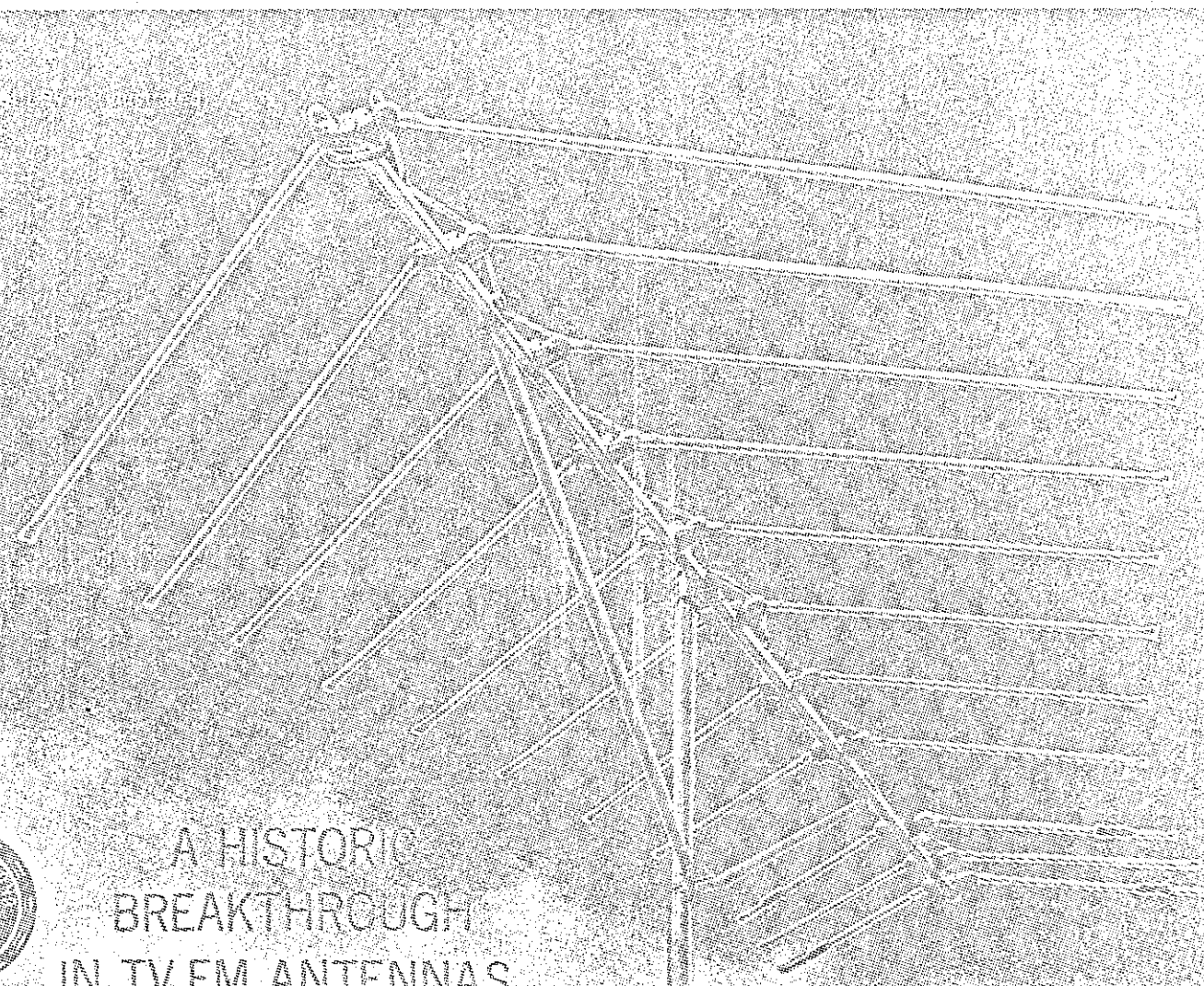

A HISTORIC BREAKTHROUGH IN TV FM ANTENNAS

**AAA* GOLD BOND ALDORIZED* — TO KEEP ANTENNA
LOOKING LIKE NEW—WORKING LIKE NEW!**

*Attractive, Anti-Corrosive Armor impregnates all inside and outside surfaces with golden iridescent coating that beautifies appearance . . . improves electrical conductivity. Will never chip or peel — actually heals itself from damage. The same alodizing meets military specifications for use on all spacecraft.

Meets requirements of MIL-C-5541 and MIL-S-5002 government specifications.

All at no extra cost to you.

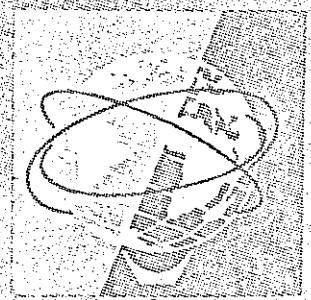

Unisphere, presented by  United States Steel

Performance has made the LPV first in antenna sales—not claims or words. JFD will gladly abide by that moment of truth that proves the true caliber of any antenna's performance—THE PICTURE IS THE PROOF!

LICENSED UNDER ONE OR MORE OF U.S. PATENTS 2,958,081; 2,985,879; 3,011,168 AND ADDITIONAL PATENTS PENDING IN U.S.A. AND CANADA. PRODUCED BY JFD ELECTRONICS CORPORATION UNDER EXCLUSIVE LICENSE FROM THE UNIVERSITY OF ILLINOIS FOUNDATION.

RECOMMENDED BY

THE FIRST TV/FM ANTENNA BASED ON THE GEOMETRICALLY-DERIVED LOGARITHMIC-PERIODIC SCALE DEVELOPED BY THE ANTENNA RESEARCH LABORATORIES OF THE UNIVERSITY OF ILLINOIS FOR SATELLITE TELEMETRY.

No longer must you sacrifice directivity or gain to obtain broader bandwidth, as with single-channel Yagis and "all-channel" Yagi types. Now the new JFD Log-Periodic LPV breaks through the bandwidth barrier to put an end to cumbersome antenna compro-

mises. The reason?... The patented geometric concept - $\frac{L_{n+1}}{L_n} = \frac{L_{n+2}}{L_{n+1}}$ that scientifically formulates individual cells (dipole lengths and spacings) to bring you performance that's frequency independent for:

- **HIGHER FORWARD GAIN** Element for element you get two to three times more gain than with similar-priced competitive makes. Flat gain across each channel, too, for vivid color rendition. (More driven elements do it.)
- **SHARPER DIRECTIVITY** Because the LPV has bandwidth to spare. Its narrow unidirectional beam does not change with frequency—does not intercept the ghosts and interference picked up by other broad main-lobed competitive makes.
- **LOWER VSWR** Down to 1.2 to 1—derived from optimum impedance match across the VHF and FM Stereo bands.
- **GOLD ALODIZED** Electrically conductive golden alodizing that is part of the aluminum—assures continuous signal transfer—does not insulate contact points like competitive anodizing.
- **HIGHER FRONT-TO-BACK RATIOS** All elements are fed in phase opposition to reinforce signals arriving from the front end. The crossed harness creates a 180 degree phase shift in the signal path from rear—effectively cancelling out rear pick-up of unwanted signals. (e.g., the LPV11 maintains a front-to-back ratio of 35 db on each VHF channel).

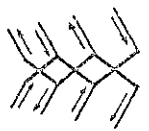

Model LPV17: 18 Active Cells and Director System for areas up to 175 miles distant. \$59.95 list.



Model LPV14: 15 Active Cells and Director System for areas up to 150 miles distant. \$49.95 list.



Model LPV11: 11 Active Cells and Director System for areas up to 125 miles distant. \$39.95 list.



Model LPV8: 8 Active Cells and Director System for areas up to 100 miles distant. \$29.95 list.

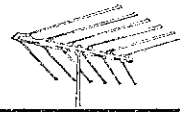

Model LPV6: 6 Active Cells for areas up to 75 miles distant. \$21.95 list.



Model LPV4: 4 Active Cells for areas up to 50 miles distant. \$14.95 list.

Harmonically Resonant V-Elements, Operating on the Patented Log-Periodic Cellular Formula, in the Fundamental and Third Harmonic Modes, Provide Flawless COLOR... Black and White TV... FM Stereo!

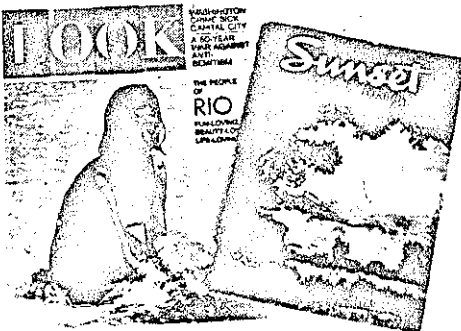

THE ANTENNA AMERICA KNOWS BEST!

The technical press...the news press...the consumer press...the trade press—never before have so many so acclaimed a new TV antenna!

ADVERTISED IN LOOK

One of America's most vital and widely read magazines—now alerting millions to the new Log-Periodic antenna concept.

ADVERTISED IN SUNSET

The favorite "home" magazine of millions.

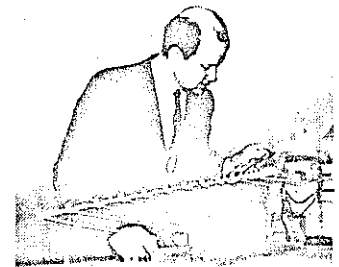

Professor Paul Mayes of the Antenna Research Laboratories of the University of Illinois, originator of the log-periodic V-dipole antenna concept.

ORDER NOW FROM YOUR JFD LPV DISTRIBUTOR AND STEP UP INTO THE MODERN LOG-PERIODIC ANTENNA ERA OF PERFORMANCE AND PROFITS!

JFD

THE BRAND THAT PUTS YOU IN COMMAND OF THE MARKET

JFD ELECTRONICS CORPORATION

15th Avenue at 62nd Street, Brooklyn 19, N.Y.

JFD Electronics-Southern Inc., Oxford, North Carolina
JFD International, 15 Moore Street, New York, N.Y.
JFD Canada, Ltd., 51 McCormack Street, Toronto, Ontario, Canada
401-144 W. Hastings Street, Vancouver 3, B.C.

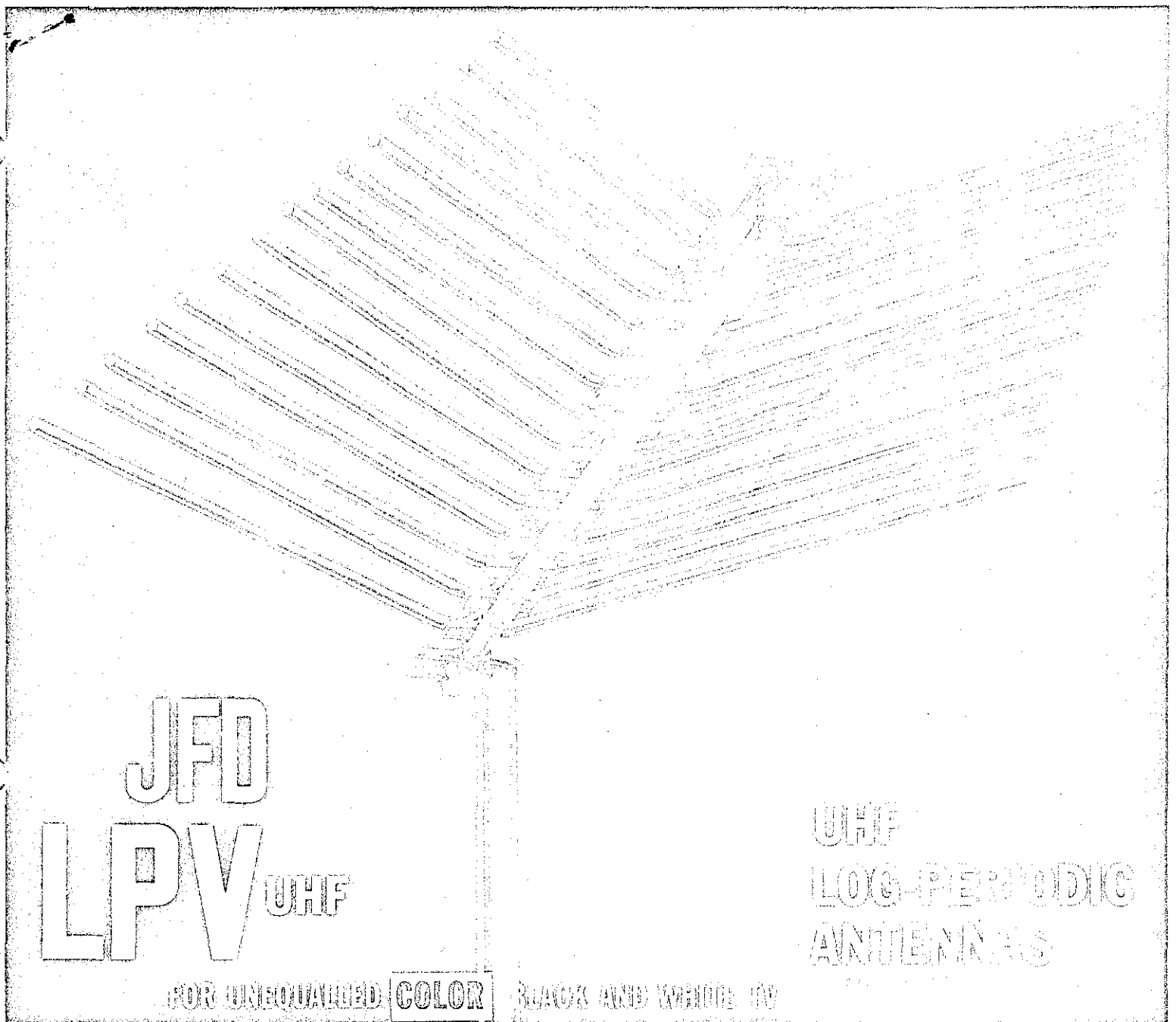

JFD
LPV UHF

UHF
LOG-PERIODIC
ANTENNAS

FOR UNEQUALLED COLOR BROADCAST AND WIDE TV

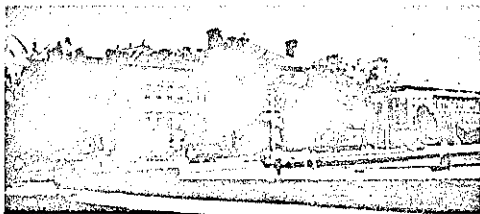

from the Champaign Illinois Antenna Research and Development Laboratories of JFD...

**the first UHF antenna design based
on the patented Log-Periodic LPV formula of the
Antenna Research Laboratories of the University of Illinois!**

Again the big news in the antenna industry comes from JFD—world leader in advanced antenna research. Four new designs that bring to UHF the same patented frequency independent log-periodic performance that revolutionized VHF reception.

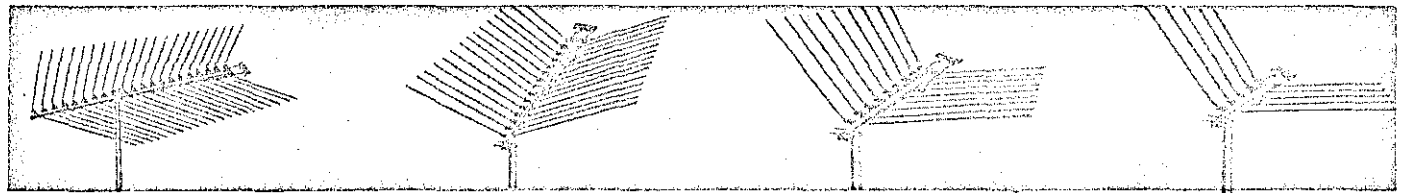

4 UHF LOG-PERIODICS FOR EVERY PROBLEM, EVERY LOCATION

model LPV-U21

model LPV-U15

model LPV-U9

model LPV-U5

X B 31 *[Handwritten signature]*

JFD

ANTENNA RESEARCH

ALL-NEW UHF

FOR UNEQUALLED **COLOR**-BLACK AND WHITE TV

The JFD Log-Periodic LPV concept is the most important antenna discovery since the invention of the Yagi. Introduced on October 22, 1962, it quickly *obsoleted* all other VHF antennas to become today's most widely used and acclaimed broadband configuration.

Now JFD moves the state of the art another step ahead with a powerful new UHF version of the Log-Periodic LPV.

COMPARE THESE FEATURES WITH THE UHF ANTENNA YOU ARE NOW USING!

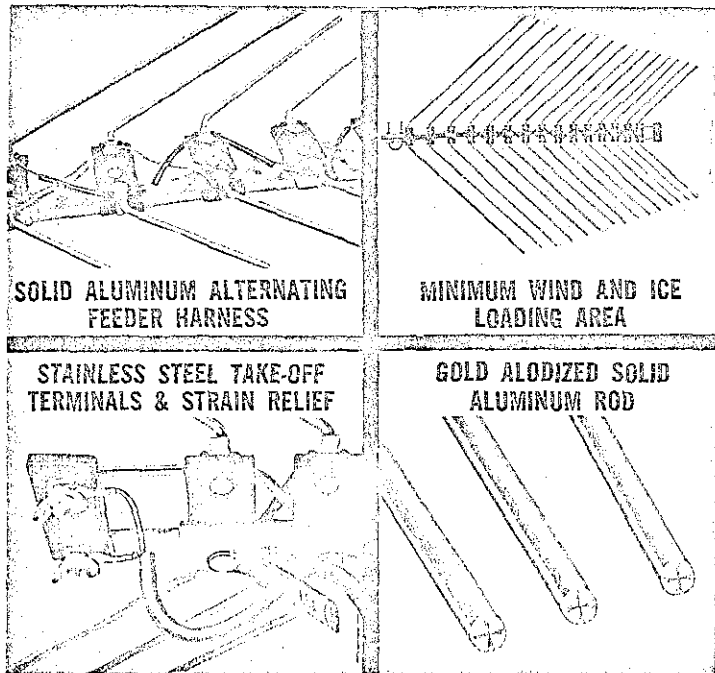

- 30% to 50% more effective gain and directivity than corner reflectors and grid screen bowtie-reflectors.
- Excellent front-to-back ratios and 300 ohm impedance match maintain exceptionally flat response across entire UHF band.
- Also deliver superior reception on VHF Channels 7 to 13—an exclusive JFD feature.
- Pinpoint horizontal beam sharpness seeks out desired UHF channels — shuts out ghosts and interference.
- Elements made of indestructible **gold alodized solid aluminum** rod that knows no climate, stays like new.
- **Factory-preassembled** — not a single screw to tighten—just unpack and mount on mast in seconds.
- **Rigidized one-piece** construction — all parts are fixed in position.
- **Bantam-sized inline** design offers least wind and ice loading area.
- Can be stacked for additional **+3 db UHF** and **+1½ db Channels 7 to 13** gain where needed.

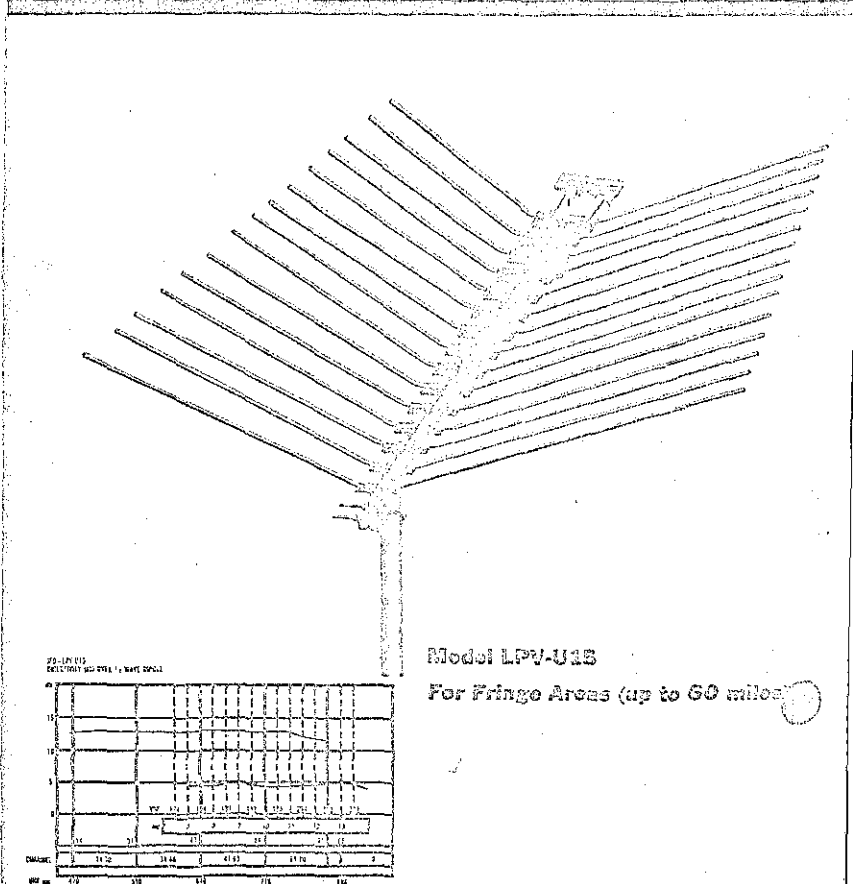
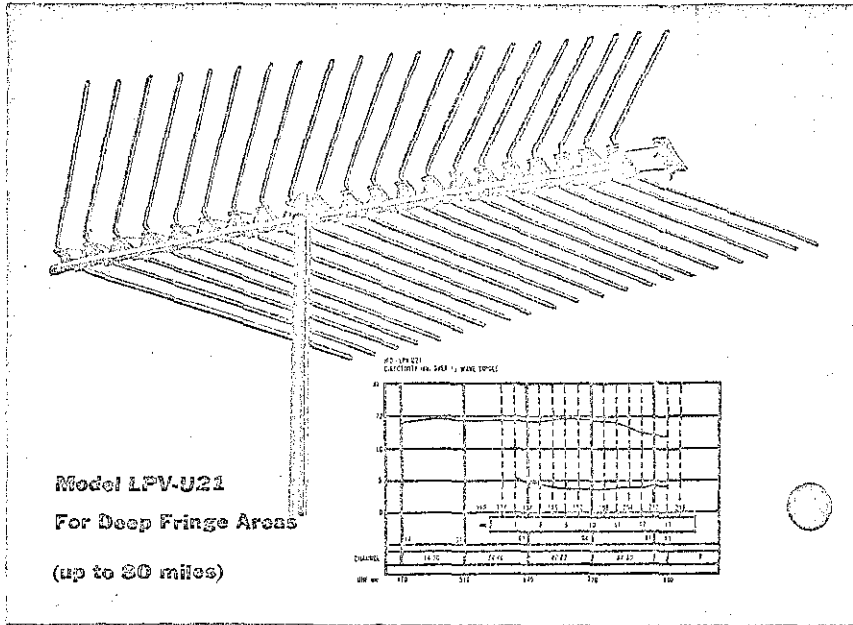

MOVES YOU AHEAD WITH THE LOG-PERIODIC LPV-U

$$\frac{L(n+1)}{L_n} = \tau$$

ON CHANNELS 14 TO 83—PLUS VHF HIGH BAND PERFORMANCE!

Formulated according to the patented geometrically derived logarithmic-periodic scale of the Antenna Research Laboratories of the University of Illinois, JFD UHF Log-Periodics give you a custom-antenna answer for any UHF reception problem. Four different models cover every location need . . . from the city to the fringes. Each is deluxe-constructed of Gold Bond Alodized aluminum in the same quality tradition of their famed VHF counterpart—the original LPV. Each delivers the same excellent values of gain, directivity, VSWR and impedance which are characteristic of JFD Log-Periodic performance.

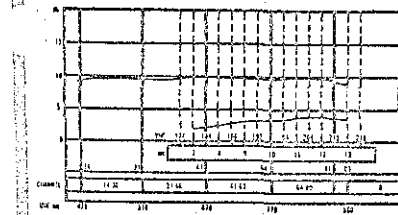
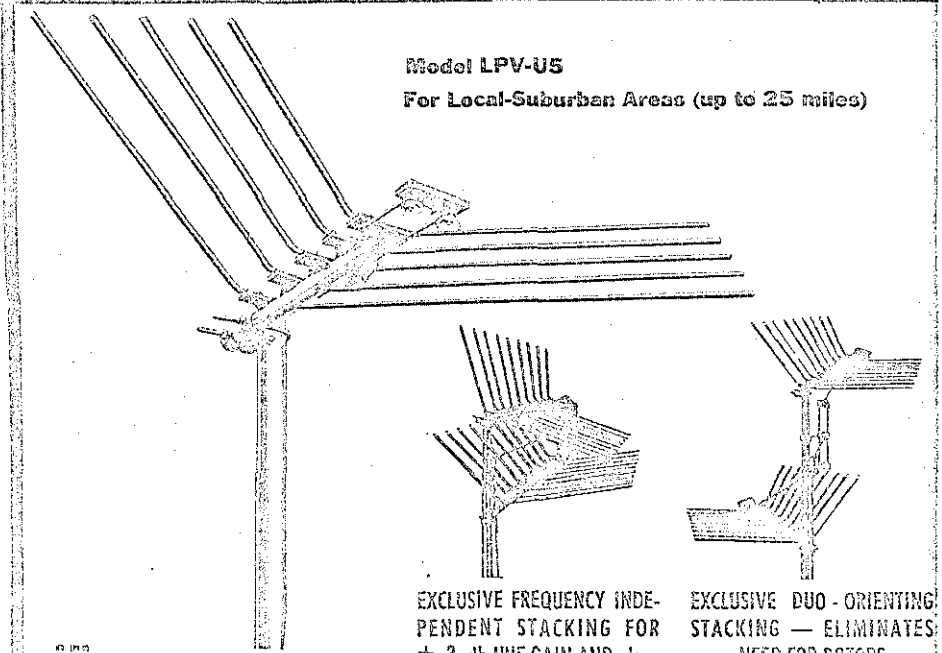
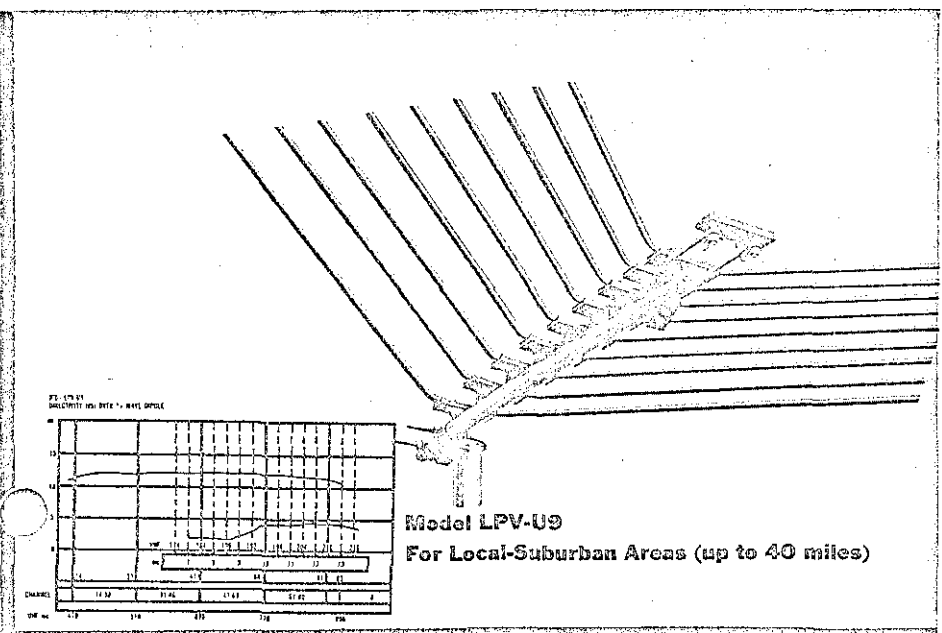

EXCLUSIVE FREQUENCY INDEPENDENT STACKING FOR + 3 db UHF GAIN AND + 1½ db. ch. 7 to 13 GAIN
Frequency independent Log Periodic stacking preserves the LPV-U's excellent impedance match and maintains constant gain and uniform operation.
No. J187 Stacking Transformer \$3.00 List

EXCLUSIVE DUO-ORIENTING STACKING — ELIMINATES NEED FOR ROTORS
Any two LPV-U's (same or different) can be oriented in different directions, when mounted together with special J185 special stacking transformer without a rotor.
No. J185 Duo-Orienting Stacking Transformer \$2.50 List

For Deep Fringe Areas (up to 80 miles)

Overall dimensions: 65" x 31" Weight: 7 lbs. approx.
Model LPV-U21 21 Active Cells \$27.95 List
OUTPERFORMS 12-BAY BOWTIE-REFLECTOR . . .
IN GAIN!
UHF—14 to 15 db (to 830 mc) 11 db at 890 mc.
VHF—Ch. 7 to 13—4 to 6 db.
Special stacking transformers available for + 3 db UHF gain and + 1½ db Ch. 7-13 gain.
IN DIRECTIVITY!
"E" HORIZONTAL PLANE PATTERN: 26° Average Beamwidth.
"H" Vertical Plane PATTERN: 40° Average Beamwidth.
IN VSWR: Under 2:1 to 770 Mc, rising gradually to under 2.8:1 in translator band.
IN FRONT-TO-BACK RATIOS! UHF up to 26 db, VHF up to 30 db.
300 OHM NOMINAL IMPEDANCE.

For Fringe Areas (up to 60 miles)

Overall dimensions: 40" x 31" Weight: 5 lbs. approx.
Model LPV-U15 15 Active Cells \$18.95 List
MORE EFFECTIVE GAIN THAN 8-BAY GRID SCREEN BOWTIE!
UHF—12 to 13 db (to 830 mc) 10 db at 890 mc.
VHF—Ch. 7 to 13—4 to 5 db.
Special stacking transformers available for + 3 db UHF gain and + 1½ db Ch. 7-13 gain.
SHARPER DIRECTIVITY THAN 8-BAY BOWTIE!
"E" (Horizontal) PLANE PATTERN: 27° Average Beamwidth.
"H" (Vertical) PLANE PATTERN: 60° Average Beamwidth.
VSWR: Under 2.1 to 770 mc rising gradually to under 2.8:1 in translator band.
TOPS 8-BAY BOWTIE IN FRONT-TO-BACK RATIOS!
UHF up to 28 db, VHF up to 25 db.
300 OHM NOMINAL IMPEDANCE.

For Local-Suburban Areas (up to 40 miles)

Overall dimensions: 28" x 30" Weight: 3 lbs. approx.
Model LPV-U9 9 Active Cells \$12.50 List
MORE EFFECTIVE GAIN THAN 4-BAY GRID SCREEN BOWTIE-REFLECTOR!
UHF—10 to 12 db, VHF Ch. 7 to 13—2 to 4 db.
Special stacking transformers available for + 3 db UHF gain and + 1½ db Ch. 7-13 gain.
BETTER DIRECTIVITY THAN 4-BAY BOWTIE-REFLECTOR!
"E" (Horizontal) PLANE PATTERN: 28° Average Beamwidth.
"H" (Vertical) PLANE PATTERN: 85° Average Beamwidth.
VSWR: Under 2:1 across UHF band.
BETTER FRONT-TO-BACK RATIOS THAN 4-BAY BOWTIE-REFLECTORS!
UHF up to 31 db, VHF up to 12 db.
300 OHM NOMINAL IMPEDANCE.

For Local-Suburban Areas (up to 25 miles)

Overall dimensions: 15" x 30" Weight: 3½ lbs. approx. (for 2)
Model LPV-U5 5 Active Cells \$6.95 List
MORE EFFECTIVE GAIN THAN CORNER REFLECTOR!
UHF—9 to 10 db.
VHF—Ch. 7 to 13 2 to 4 db.
Special stacking transformers available for + 3 db UHF gain and + 1½ db Ch. 7-13 gain.
NARROWER DIRECTIVITY THAN CORNER REFLECTOR!
"E" (Horizontal) PLANE PATTERN: 29° Average Beamwidth.
"H" (Vertical) PLANE PATTERN: 110° Average Beamwidth.
VSWR: Under 2:1 across UHF band.
FRONT-TO-BACK RATIO SUPERIOR TO CORNER REFLECTORS!
UHF up to 28 db.
VHF up to 10 db.
300 OHM NOMINAL IMPEDANCE.

why the LPV-U makes
all other antennas
obsolete

how the Log
Periodic
LPV-U works

Developed to formula and not by chance—the one unique design and principle of the Log Periodic LPV solves all antenna needs...

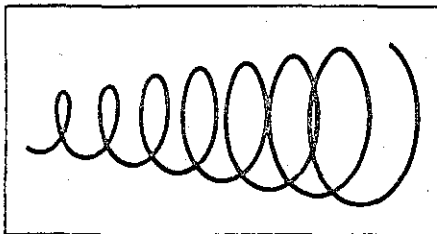

The JFD LPV antenna is a direct descendant out of the logarithmic conical spiral antenna used on the Transit satellite. This basic design is FREQUENCY INDEPENDENT—it works like a conical waveguide to yield almost constant gain, matched impedance and a unidirectional polar pattern across an extremely wide band of frequencies.

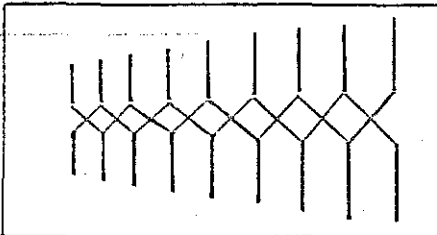

Dipole version of spiral antenna has elements whose length and spacing is determined by formula derived from conical spiral geometry, so that antenna acts like a spiral with parts of coils missing. A logarithmic scaling multiplier ties the dipoles together into active multi-element cells for each frequency. Crossed phasing harness inserts a 180-degree phase shift between dipoles that cancels signals from rear, reinforces signals from front.

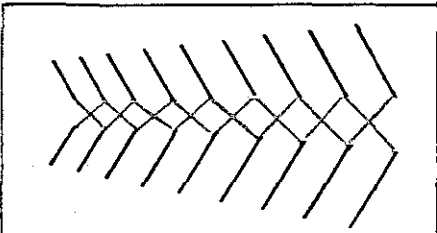

JFD's logarithmic LPV antenna goes one step further— increases gain and front-to-back ratio while maintaining frequency independence. Forward V-ing of elements shrinks rear radiation lobes, narrows forward beam for sharp directivity, helping to eliminate ghosts and adjacent channel interference.

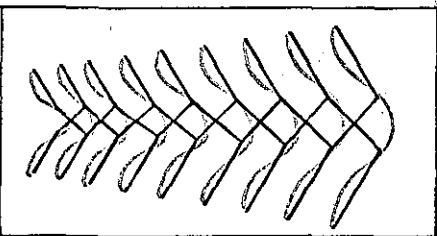

Each antenna in the LPV series consists of an array of resonant V-dipoles and crossed phasing bars, constituting a group of "cells." The size of each cell differs from the one before it by a Logarithmic factor. For any particular frequency, the active portion of the antenna centers on the resonant dipole (equal to 3-half wavelengths at that frequency), with the adjacent elements also absorbing significant signal energy. The resonances of adjacent cells overlap, so that as the frequency increases or decreases, it is transferred smoothly from one cell to the next.

THE KNOW-HOW OF THE WORLD'S NEWEST AND FINEST ANTENNA RESEARCH LABORATORIES IS BUILT INTO EACH JFD LPV ANTENNA YOU INSTALL!

The Log-Periodic concept is the result of five years of intensive electronic studies at the Antenna Research Laboratories of the University of Illinois and JFD. Located in Champaign, Illinois (home of the University of Illinois), the vast new JFD research center is the largest and most complete of its kind.

Here, a team of scientists, graduate engineers and technicians under the direction of Dr. Paul E. Mayes, who helped develop the log-periodic antenna concept, continue to break-through to new reception horizons. Using the latest electronic instruments and equipment this outstanding JFD staff is revolutionizing the state of the antenna art.

The VHF Log-Periodic LPV and the UHF Log-Periodic LPV, are examples of some of the engineering "firsts" of these JFD Laboratories.

AT THE MOMENT OF TRUTH, THE PICTURE IS THE PROOF THE JFD LOG-PERIODIC LPV WORKS BEST!

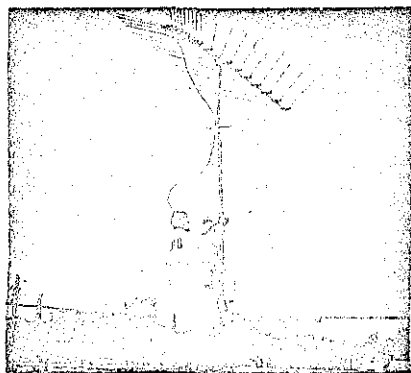

JFD

JFD ELECTRONICS CORPORATION
15th Avenue at 62nd Street, Brooklyn, N. Y. 11219

JFD Electronics-Southern Inc., Oxford, North Carolina
JFD International, 64-14 Woodside Ave., Woodside 77, N. Y.
JFD Canada, Ltd., 51 McCormack Street, Toronto, Ontario, Canada

1332-0

Get the Lion's Share of TV Antenna Business (Stop CATV Competition, Too) With

JFD LPV[®] log periodics



Compare what the JFD LPV offers you against all others!

Compare COMPLETENESS OF LINE!

Only JFD offers you the most *complete* line of all...in step-up models...in VHF/UHF /FM bands...in VHF (ch. 2-13)...in UHF (ch. 14-83)...in FM/ Stereo.

Compare ENGINEERING!

JFD leadership in antenna design is an acknowledged fact. JFD Champaign, Illinois R & D facilities include the world's newest and most advanced antenna laboratories. Here a team of scientists, graduate engineers and technicians, under the direction of Dr. Paul E. Mayes, are revolutionizing the state of the antenna art. This priceless scientific know-how and integrity stand behind each JFD Log Periodic you see.

Compare PERFORMANCE!

JFD LPV's are the first and only antennas based on the geometrically-derived *Logarithmic Periodic* scale developed by the Antenna Research Laboratories of the University of Illinois and used in satellite telemetry. Result: frequency-independent performance that de-

livers a combination of superior gain, 300 ohm impedance match, pinpoint directivity, and front-to-back ratio never before possible across the *entire* band.

Compare COLOR RECEPTION!

JFD Log Periodic response is *flat* across each channel for true, crisp color picture resolution.

Compare CONSTRUCTION!

Life-time stainless-steel take-off terminals that can never corrode, "tank-turret" element brackets, non-breakable heavy-wall Implex A acrylic insulators, twin U-bolts with 6 inch mast grip span; supple, permanently riveted aluminum drive line rod, electrically conductive gold alodizing, plus a host of other exclusive mechanical improvements.

Compare ADVERTISING AND PROMOTION!

A versatile selection of indoor and outdoor sales helps... advertisements in LOOK, SUNSET and other national and local consumer publications... in newspapers... on television... that sell your best prospects.

FIGHT CATV WITH THE JFD LPV! Keep CATV out of your area with JFD Log Periodics (such as the 82-channel LPV-VU) which provide viewers with *more* channels—sharper reception—richer color—plus FM stereo. Don't install inferior antennas that open the door to CATV. Install the best to get the best performance—the LPV!

STATES DISTRICT COURT
NORTHERN DISTRICT OF ILLINOIS
BEFORE JUDGE HOFFMAN
DEFENDANT EX. NO. 25
DOROTHY L. BRACKENBURY
OFFICIAL COURT REPORTER

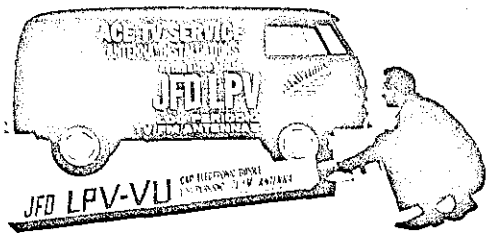

Don't Be 1/2 Set... With JFD LPV Log

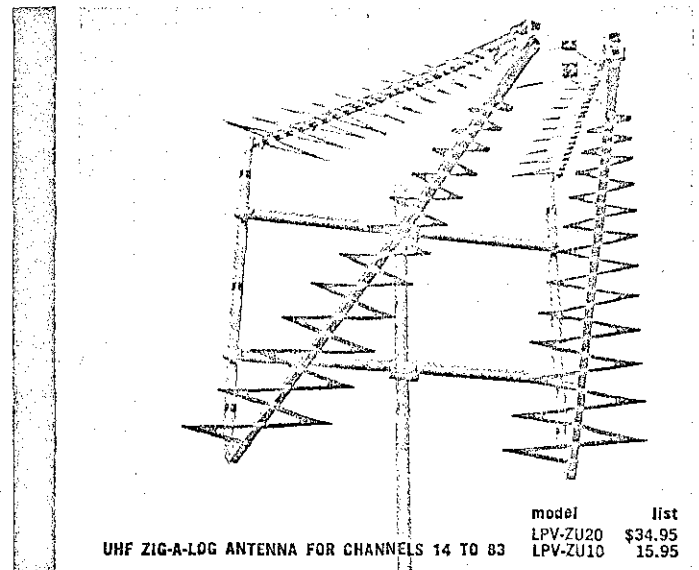
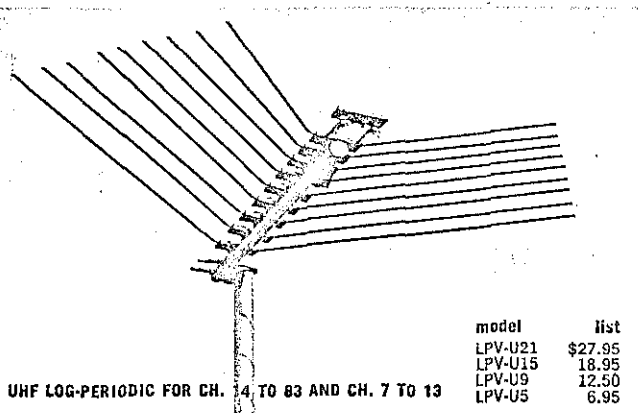
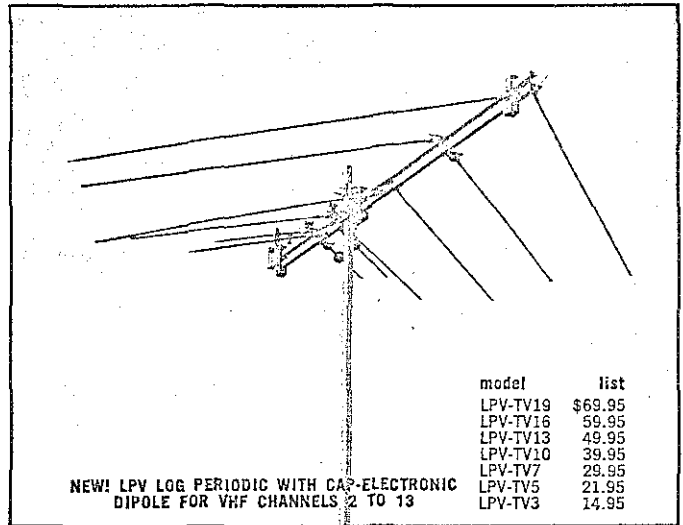
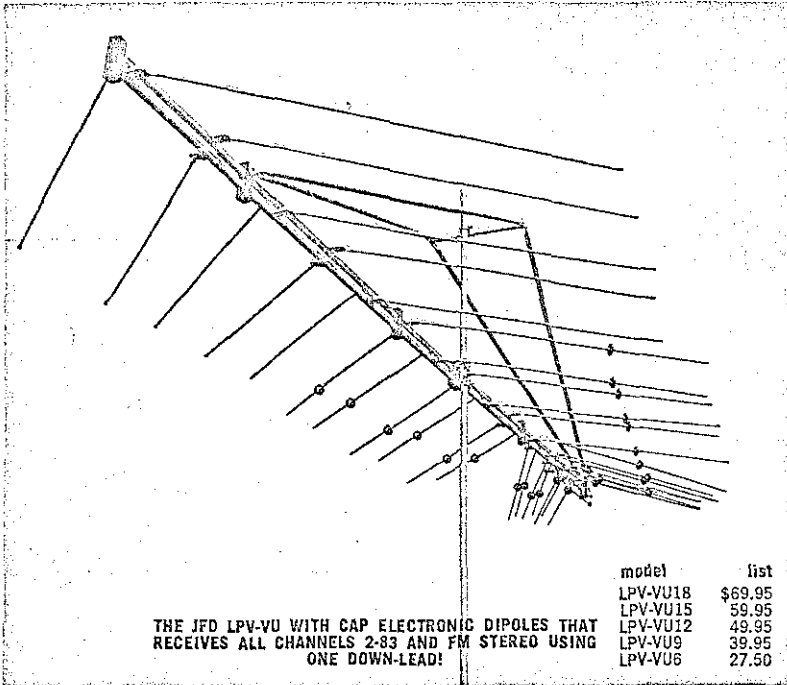

Only JFD offers You LPV Log Periodics for VHF (Ch.2-13)...UHF

GET THE LION'S SHARE OF ANTENNA BUSINESS (FLATTEN CATV COMPETITION, TOO) BY FEATURING THE JFD LPV-VU LOG PERIODIC! THIS NEW GENERATION OF LOG PERIODIC ANTENNAS DELIVERS WHAT VIEWERS WANT—MANY MORE STATIONS...VHF CHANNELS 2 TO 13...UHF CHANNELS 14 TO 83...FM/STEREO. GIVES THE CLEAN, UNIFORM SIGNAL SETS NEED ESPECIALLY FOR VIVID COLOR RECEPTION.

Only the LPV follows the patented frequency independent Log Periodic antenna formula developed by the Antenna Research Laboratories of the University of Illinois. This new log periodic cellular concept provides you with a combination of gain, bandwidth, directivity and impedance match never before possible with conventional antenna designs.

You can actually see the difference in truer color purity, in greater contrast, in finer detail—not on just some of the channels but all of the channels! Small wonder more JFD Log Periodics were installed in the last 12 months than any other brand. **PREFERRED BY MORE N. Y. WORLD'S FAIR PAVILIONS...** New York World's Fair exhibitors demand flawless color reception. That's why the House of Good Taste, Ma-



sonic Pavilion, Formica House, Eastman Kodak Exhibit, New York City Exhibit, House of Japan and other Fair showplaces chose the JFD LPV. This exclusive preference is pre-selling millions of Fairgoers—opening the door for more LPV sales by you.

WHY THE LOG PERIODIC IS THE MOST DRAMATIC BREAK WITH ANTENNA TRADITION SINCE DR. YAGI INVENTED THE YAGI... Up until the JFD Log Periodic, it was not possible to devise a truly broadband antenna except by "compromise" design that had to give up vital gain to get wider bandwidth... or had to degrade directivity for better impedance. Burdensome parasitics were piled on to try to compensate for gain "suck-outs", ghost-prone polar patterns, and inadequate bandwidth. This pyramided performance complications resulting in signal-sapping standing waves and impedance matches—and yet were only effective at the band edges.

Through the use of the revolutionary new logarithmic periodic formula, the entire frequency range is covered with dipole



Be All Set— Periodic TV & FM Antennas

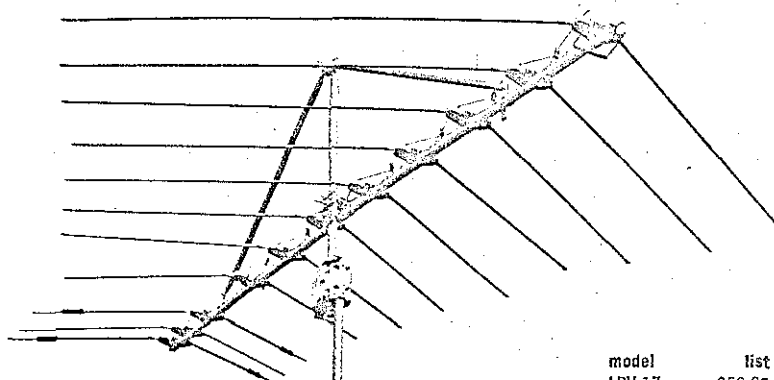
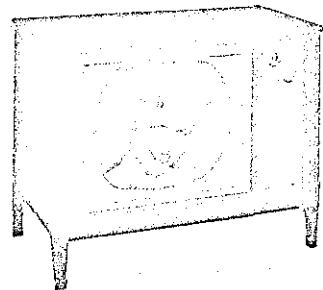

THE FAMOUS LPV FEATURING ADVANCED
NEW LOG-PERIODIC PARAMETERS!
FOR VHF CHANNELS 2 TO 13 AND FM STEREO

model	list
LPV-17	\$59.95
LPV-14	49.95
LPV-11	39.95
LPV-8	29.95
LPV-6	21.95
LPV-4	14.95

THE FIRST LOG PERIODIC TRAPEZOID INDOOR ANTENNA
FOR CHANNELS 2 TO 13
ULTRA VU-VISYA VHF-UHF INDOOR ANTENNA

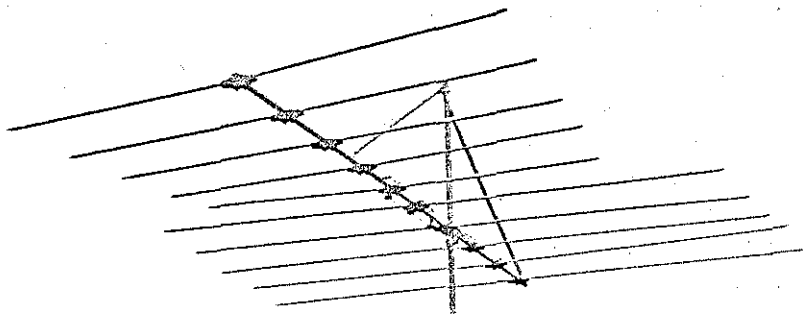
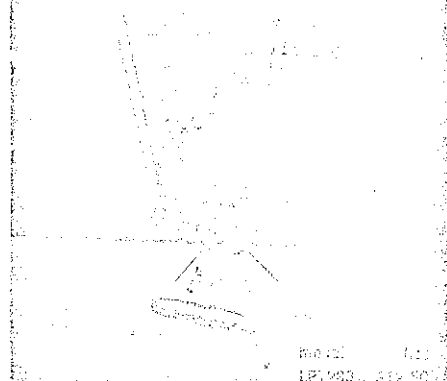

LOG PERIODIC FM STEREO ANTENNA

model	list
LPL-FM10	\$49.95
LPL-FM8	39.95
LPL-FM6	29.95
LPL-FM4	19.95

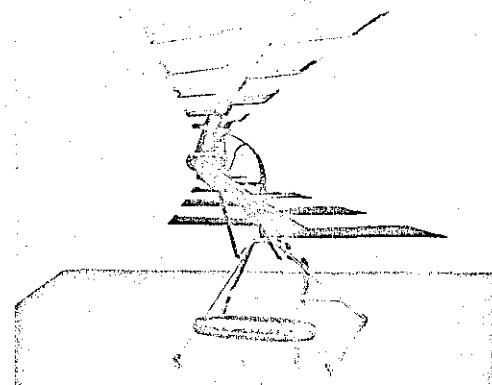

VHF-UHF LOG PERIODIC INDOOR ANTENNA—CHANNELS 2 TO 13
model list
LPT-100 \$7.50

(Ch. 14-83)...FM/Stereo...VHF/UHF/FM—COLOR & Black/White

groups (cells) of overlapping resonances. These harmonically resonant V-dipoles result in a frequency-independent performance. The LPV's inherently high gain, sharp directivity, 300 ohm impedance match and flat response are virtually constant across the entire band.

AND ONLY THE JFD LPV HAS IT!... The JFD LPV is the product of the world's largest and newest antenna laboratories. Here, in the JFD Campaign, Illinois R & D Research Center, a team of scientists and engineers, under the direction of Dr. Paul E. Mayes, are revolutionizing the state of the antenna art.

MECHANICALLY SUPERIOR!... COMPARE CONSTRUCTION!... Life-time stainless-steel take-off terminals that can never corrode, "tank-turret" element brackets, tough heavy-wall Implex A acrylic insulators, twin U-bolts with 6 inch mast grip span; supple, permanently riveted aluminum drive line rod; electrically conductive gold alodizing; plus a host of other exclusive mechanical improvements.

FIGHT CATV WITH THE JFD LPV! Keep CATV out of your area with JFD Log Periodics (such as the 82-channel LPV-VU) which provide viewers with more channels—sharper reception—richer color—plus FM stereo. Don't install inferior antennas that open the door to CATV. Install the best to get the best performance—the LPV!

ADVERTISED IN LOOK, SUNSET... COMPARE ADVERTISING AND PROMOTION!... A versatile selection of indoor and outdoor sales helps... advertisements in LOOK, SUNSET and other national and local consumer publications... in newspapers... on television... sell your best prospects.

Now is the time and your JFD distributor is the place to stock up and step up into big-league LPV Log Periodic profits.

SEE WHY AT THE MOMENT OF TRUTH THE PICTURE IS THE PROOF THE JFD LPV LOG PERIODIC WORKS BEST!

Licensed under one or more of U.S. Patents 2,958,081; 2,985,879; 3,011,168; 3,108,280; 3,150,376 and additional patents pending in U.S.A. and Canada. Produced by JFD Electronics Corporation under exclusive license from the University of Illinois Foundation.

JFD JFD ELECTRONICS CORPORATION
15th Avenue at 62nd Street, Brooklyn, N. Y. 11219
JFD Electronics-Southern Inc., Oxford, North Carolina
JFD International, 64-14 Woodside Ave., Woodside 77, N. Y.
JFD Canada, Ltd., 51 McCormack Street, Toronto, Ontario, Canada

copyright 1965, JFD Electronics Corp.

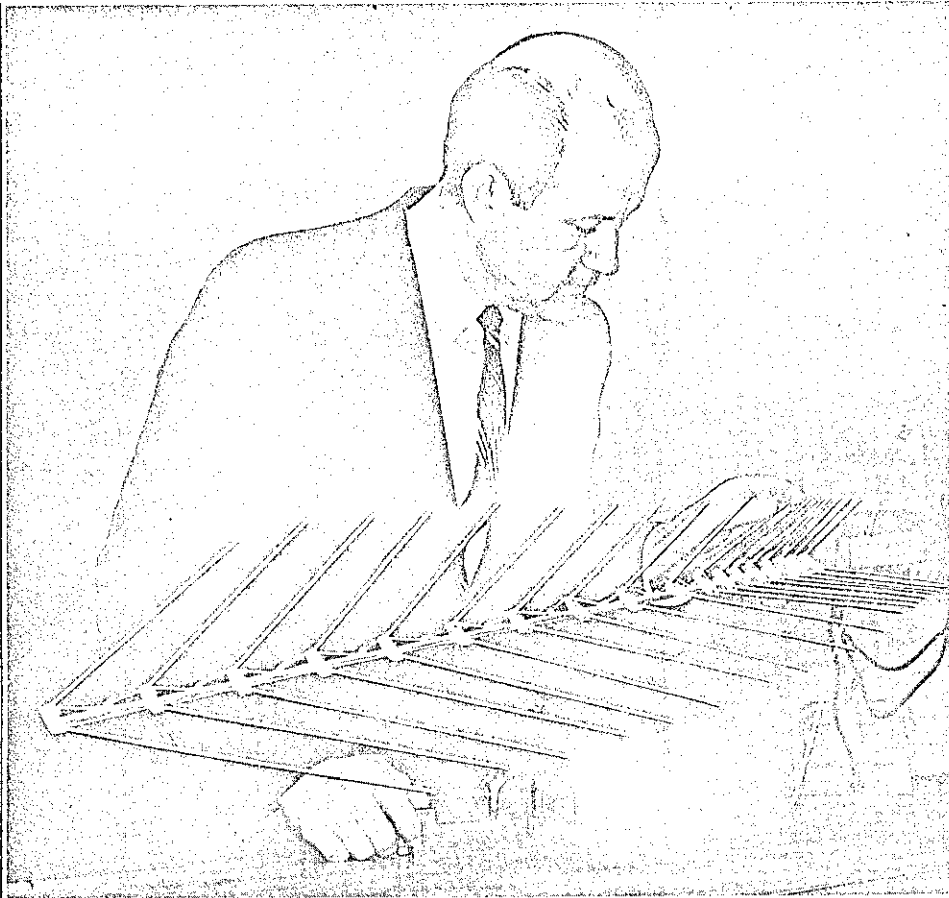

News-Gazette Photo by Ian Ingalls

Dr. Paul E. Mayes inspects and checks out one of log-periodic family.

* * * * *

UI's Mayes, Team Develop Better TV Antennas

By **HANK HOKAMP**
News-Gazette Staff Writer

Remember how you used to shake and pound your radios, trying to "get the darn things" playing again? That was then ... but how about now?

Yes, you've found a new culprit to cuss and perhaps shake ... and to top things off, it's usually the most popular piece of furniture in the house ... the television set.

Thanks to the efforts of such men as Dr. Paul E. Mayes, professor of electrical engineering at the University of Illinois, and his associates, this situation may well become a rarity instead of commonplace.

"For many years no attempt was made to achieve a constant pattern regarding the development of VHF, UHF, VHF-UHF, and FM antennas," Dr. Mayes said. "Today there exists a need for antennas which will cover a number of isolated frequency bands rather than covering continuously the entire spectrum between the lowest and highest frequencies of interest," he said.

Dr. Mayes and his colleagues have done just this .. developed

a number of TV antennas which are presently being sold to the consumer public by electronic parts companies throughout the nation.

Another series of antennas, this time a family of four designed for FM Stereo radios, were released for production July 1. These antennas were developed by Mayes and Ron Grant, chief engineer at the JFD Antenna Laboratories located at 714 So. Randolph, C.

The JFD Electronics Corporation, Brooklyn, N.Y., manufactures these antennas and is licensed by the UI Foundation. JFD extends exclusive rights to the UI Foundation for its patented log - periodic - antenna concept.

Regarding the TV antennas developed by Mayes and his associates the largest log-periodic antenna in this family is the JFD Log-Periodic LPV antenna. This antenna can conquer the super fringe area up to 175 miles from a transmitter. It's considered to be the best for color and black and white reception regarding the capabilit-

ies of the "family."

The smallest LPV antenna reaches out to 50 miles from the transmitter. This is all one needs to attain local reception.

The second antenna in this family is the LPV-U, or the first UHF antenna design based upon the patented LPV formula by the laboratories at the UI. This antenna is used for high band performance on channels 14 to 83. Four models are now available and range up to 80 miles regarding reception.

No commercial antenna has had uniform high gain over the complete VHF television band. The log-periodic V, the third antenna available in this series, takes care of this unique situation. Out of various experiments led by Prof. V. H. Rumsey and Prof. J. D. Dyson, both members of the electrical engineering department at the UI, this log spiral antenna became available.

What is called the strongest antenna developed for UHF is the Zig-A-Log antenna, a new concept for local or long distance reception on channel 14 to 83.

This Zig-A-Log antenna is said to offer much less wind resistance, much less ice and snow loading area, and better directive gain.

Log-periodic or logarithmic antennas make-up a family that have a unique fundamental design. These designs have been developed by Mayes and his associates since 1954 at the UI and include the presence of a three-fold purpose.

These antennas have been and are presently being used for satellite tracking at missile range locations at points along the Atlantic and Pacific Oceans as well as at Cape Kennedy.

Secondly, the log-periodic antennas are used by communication networks of the Armed Forces. These new type designs can be made to cover any range of frequencies.

The third use of the antennas are found in commercial circles mentioned before. The TV log-periodic antennas have been developed since 1954 with the four FM Stereo antennas to be placed on the market in the near future.

Where does this antenna research take place? Largely at the JFD Laboratories where 12 undergraduate, graduate and post-graduate students are engaged in this basic research in log-periodic type antennas for television, FM, amateur and military application.

The new JFD Antenna Laboratory is located in the Interstate Research. Park northwest of Champaign with the construction scheduled to be completed by Sept. 1. Operations at the new laboratory will not begin until Oct. 1. The facilities will be used for the development of new antenna designs for all-channel VHF and UHF reception.

According to a survey paper recently published by Profs. E. C. Jordan, G. A. Deschamps, J. D. Dyson and Mayes, it was noted that some of the earliest broadband antennas were long wire types designed to operate in the high frequency or short-wave band or perhaps in the low frequency band. Among these antennas the well-known rhombic or equilateral parallelogram shaped antenna has held a high place since the days of radio. The log-periodic antenna is a revolutionary development in design.

Other information gathered during the survey was presented for the express purpose of providing the nonspecialist with a basic understanding of the remarkable advances which have taken place over the past decade in the field of broadband antennas.

Since the law now requires all TV sets to come from the factory with a UHF "hook-up", perhaps this need for antennas to cover a number of isolated frequency bands could open more interesting doors to interested parties such as Dr. Mayes and his associates.

revolution
in the air - JFD
LOG PERIODIC



TV ANTENNA

a dramatic new antenna
development incorporating
harmonically — resonant
V—elements operating on
the log periodic cellular
principle in the fundamental
and third harmonic modes

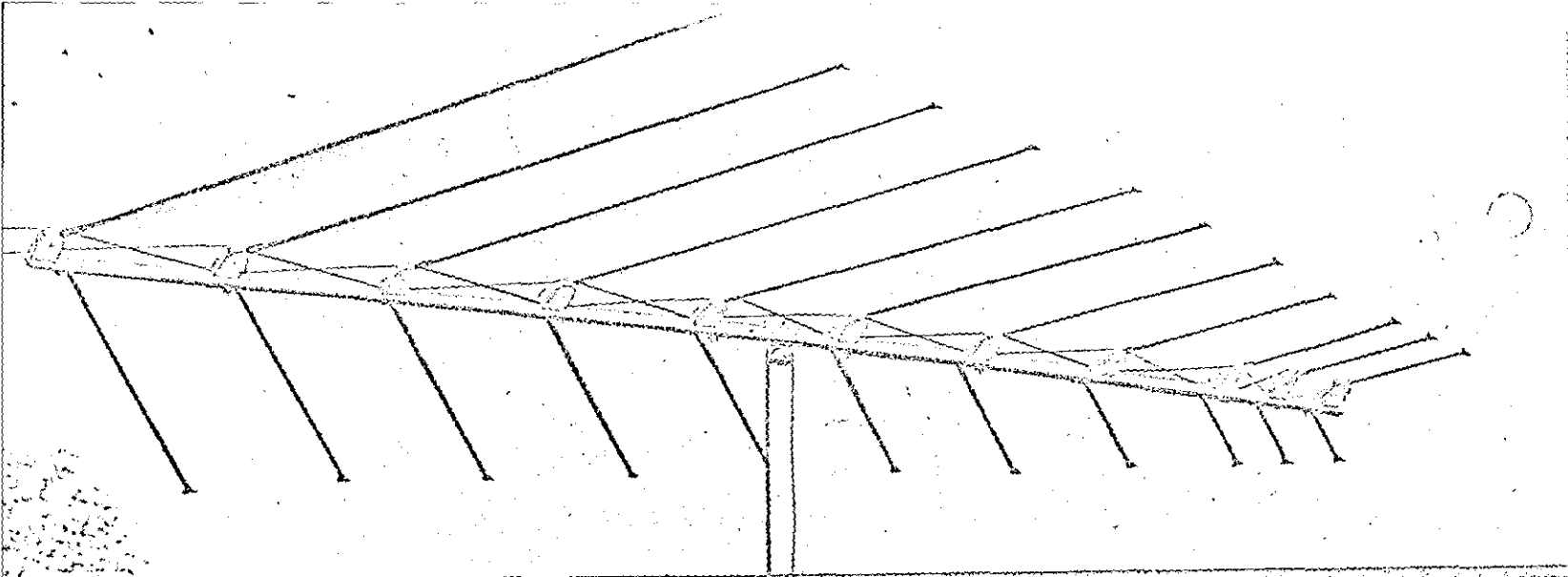

THE JFD LOG PERIODIC LPV:

a historic breakthrough in TV antenna design



Significant New Principles Developed for Satellite Tracking, Space Telemetry and Military Communications by University of Illinois Antenna Research Laboratory Lead to New High-Gain All-Channel Antenna "Comparable to a Yagi Array" Across the Entire Band



PROFESSOR PAUL MAYES
Antenna Research Laboratory, University of Illinois.

Certain limitations have been inherent in TV antenna design for so long that they have become accepted as axiomatic. No commercial antenna devised up till now has been able to yield high gain *uniformly* over the complete VHF TV band. Therefore, it has been assumed that it is not possible to do so, except by a compromise design that gives up a little gain to get a little band-

width. The gain curves of modern TV receiving antennas are studded with peaks and valleys that attest, only too well, to their dependence on frequency.

Most antennas for fringe area reception are based on the yagi design. However, while the yagi offers high gain and high front-to-back ratio, it cannot cover the entire VHF TV band from 54 to 216 mc. A simple yagi is most effective for a single channel, a spread of only six megacycles. Modified yagis, which contain dipoles cut for the center of the low and high bands and an array of various size parasitic elements for broadening the bandwidth, generally yield good gain at the high and low ends of each band and degenerate in the middle. This has been the fate, in fact, of any antenna burdened with a large number of parasitic elements. Such elements have secondary resources which make for signal-sapping standing waves and impedance mismatches between the antenna and the transmission line. Further, they are only effective at the band edges.

In their never-ending research for better TV antennas, the engineers at JFD Electronics Corporation's antenna laboratories have long sought some new principle that could

overcome the disadvantages of compromise. The JFD flat-plane helix was a partial answer to this problem, but was effective only on the high band. The new concept underlying the design of the LPV is a genuine breakthrough for TV antennas and comes from the massive research effort of the U. S. Air Force for more effective antennas for many new applications such as space communications.

For more than eight years, a group of antenna scientists at the Antenna Research Laboratory of the University of Illinois has been experimenting with VHF and UHF antennas which have no theoretical limitations on bandwidth, and have been called frequency-independent antennas. For reliable communications, antennas are needed that are frequency independent over ranges in which the highest frequency is ten or more times the lowest. Various experiments led Professor V. H. Rumsey to suggest that an antenna shaped like the logarithmic spiral should be frequency independent. Professor J. D. Dyson directed an extensive laboratory investigation of these log-spiral antennas and out of this research came the sharply directional, yet broadband, conical spiral antenna now being used for satellite tracking and radio astronomy. One version of

this antenna is embossed on the Transit satellite, now in space.

Since the spiral is based on a logarithmic equation, it was thought that a planar antenna, whose element lengths were related to each other in the same manner, might also exhibit the same independence of frequency and uniform impedance offered by the conical spiral. Professor R. H. Du Hamel followed this line of reasoning and developed a linearly polarized antenna with pattern and impedance characteristics that did indeed have only small variations which repeat periodically with the logarithm of the received frequency. This is the basis for the *log periodic* antenna. D. E. Isbell developed the very practical log-periodic dipole array using these ideas and Professor Paul Mayes and R. C. Carrel applied the principle of element V-ing to the log periodic dipoles and developed an antenna basically suitable for television applications.

JFD antenna engineers who had early recognized the special advantages of the helix for television reception by incorporating such a design into the "satellite helix" and "star helix" antennas, worked in cooperation with the scientists at the University of Illinois to develop the final version of the *log periodic V*, or LPV,



PROFESSOR MAYES and JFD Executive Vice President EDWARD FINKEL inspect the facilities at JFD's Antenna Research and Development Center

antenna for television. The LPV promises to revolutionize the TV antenna field. Although it is now designed to cover uniformly both the low and high VHF TV bands and the FM band in between, a frequency spread of four to one, this antenna type can easily be extended to include the UHF band as well. The unique thing about the LPV antenna is that within the TV band for which it is designed, its impedance, gain, reception pattern and front-to-back ratio are virtually constant across each band. The gain for each channel is as high as that furnished by a comparable sized single channel yagi.

LOG PERIODIC CONCEPT

Essentially, the LPV antenna incorporates two separate design concepts: (1) the log-periodic factor, which determines the size and spacing of the elements and, (2) the forward V shape of the elements, which permits multi-mode operation. Let us first consider the periodic function.

The basic planar log periodic antenna is an array of dipoles in which the length of each element bears a fixed ratio to the length of the preceding element. This ratio is called the scale factor and is designated by the

Greek symbol τ (tau). The spacing between adjacent dipoles may also be similarly fixed by a ratio, σ (sigma). These relationships are shown in Figure 2, where h denotes element length and d represents the spacing between dipoles. Each dipole is equal to an adjusted half-wavelength at a different frequency, making the dipole resonant to that frequency. The scaling factors σ and τ are so chosen that the desired frequency range is covered with elements of overlapping resonances. In this way, as the frequency changes, the function of the resonant dipole will be transferred smoothly from one to the next.

Typical values of tau and sigma are 0.9 and 0.085, respectively. These, in fact, are the actual values that were used in one of the many experimental models developed in the JFD laboratories. This is a seven element antenna, 92 inches long, with h_1 , the half length of the longest element, at 56 inches. As might be imagined, the selection of tau and sigma is not like picking numbers out of a hat; they derive from many experimental models and tests which attempt to optimize the characteristics desired in a TV antenna. There is no simple equation into which numbers are dropped and the answer is forthcoming. The values

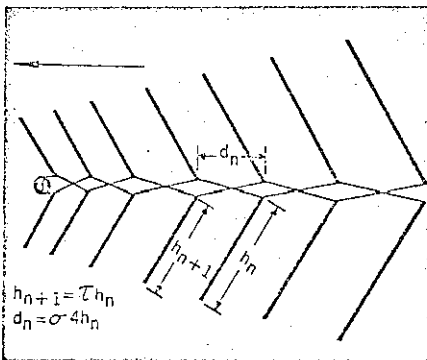

Figure 2

for tau and sigma given above and the actual ones used in the design of the LPV series by JFD engineers were selected from nomographs which themselves combine in a graphically useable form the results of many experiments and theoretical calculations.

It is important to understand that through the use of the logarithmic scaling factors in the design of the LPV, the total antenna works together for the reception of TV signals. Most conventional TV antennas consist of a group of individual elements resonant to different channel frequencies, which must then be manipulated so that they all give a reasonably good impedance and directional characteristic, like a team of wild horses that must be held together by force. In contrast, the JFD LPV is an integrated antenna with a total environmental design, all parts working together harmoniously.

Although the antenna is consistent in its action over the entire TV band, in the high end of the band there is an additional contribution made by harmonic mode reception. Because of this, it would be instructive to explain the action of the antenna on the

low TV band first and then go on to its operation for the high band.

Fundamental Operation for The Low Band

The largest dipole of the LPV antenna corresponds in length to the half wavelength of the lowest TV frequency to be received. It therefore is resonant to the fundamental wave of this frequency. Similarly, many of the other dipoles more or less correspond to the half wavelengths of the other channels in the low TV band. Although one particular dipole, the one closest to the resonant length, absorbs the greatest amount of energy at any particular received frequency, the adjacent elements also absorb some signal energy. How much the adjacent dipoles absorb is shown in Figure 3, a curve representing the distribution of current at the terminals of each dipole of a nine element LPV antenna receiving a given frequency in the center of its band. Note that while maximum energy is absorbed by one dipole, number 5, two other elements, numbers 4 and 6, absorb 60 percent as much, and even elements 3 and 7 absorb substantial amounts of signal (30 percent).

The resonant or near resonant dipole together with those adjacent elements which contribute substantial signal energy at the received frequency and the crossed phasing harness constitute the active "cell" for that particular channel. As the frequency of reception increases, i.e., at channels 4, 5 and higher, the active region of the antenna moves toward the front or what would be the apex if the antenna were a true cone. For each channel, a different cell is formed.

Ordinarily, the elements adjacent to the resonant dipole in a conventional TV antenna are nowhere near as efficient in signal absorption as is true within the cell of an LPV antenna. This is because, as has been explained earlier, the LPV is not merely a collection of resonant dipoles, which present high impedance to frequencies other than their own. The tau and sigma used in the design of an LPV are the key to providing the wide active reception region for every channel. When these two factors are selected properly, the dipoles of the active cell present a low impedance at their terminals resulting in the high energy absorption. This low impedance results from the combination of element length and spacing determined by the log periodic de-

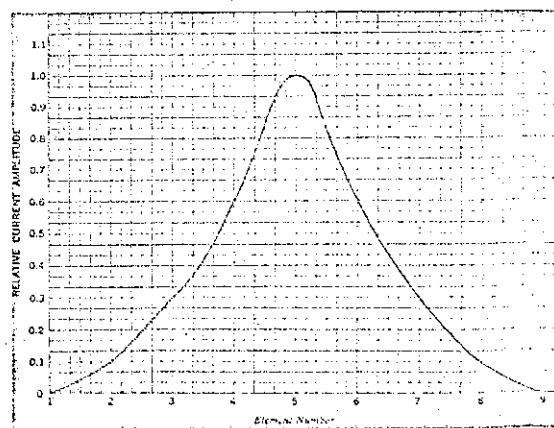

Figure 3

DEVELOPED BY THE UNIVERSITY OF ILLINOIS EXCLUSIVE FROM JFD THE LOG PERIODIC

IT COULD ONLY HAVE BEEN CREATED by such massed resources as those of a prominent university, the military, and the country's leading antenna manufacturer.

BECAUSE ITS GAIN IS INDEPENDENT OF FREQUENCY, the backward-wave LOG PERIODIC LPV functions with highest efficiency across the entire TV band. Impedance, gain, reception pattern and front-to-back ratio virtually constant across each band. Performance on any channel comparable to a tuned Yagi cut to that channel.

OUTPERFORMS PREVIOUS WIDE-BAND ARRAYS ON VIRTUALLY EVERY COUNT:

- HIGHEST GAIN — as high as 14 db. in the 17-element LPV!
- SHARPEST DIRECTIVITY — on high bands as well as low!
- HIGHEST FRONT-TO-BACK RATIO — 35 db. in the LPV-11!
- LOWEST VSWR — as low as 1.2 to 1 — with constant impedance across the full bandwidth!
- FLAT RESPONSE ACROSS BOTH VHF BANDS — with greater gain on the high band, where it's needed most (average increase of gain in high band as compared with low band: $3\frac{1}{4}$ db.)!
- BROADEST BANDWIDTH! — For brilliant color

This end-fire array is the most sensitive broad-band antenna ever made for TV. Here are unprecedented gain, a decisive end to snow and ghosts, the truest color yet (plus FM) — on all channels, from one uncluttered basic design!

MORE, FAR MORE THAN JUST A "FRINGE" SOLUTION, the LOG PERIODIC LPV delivers superior reception in all multi-channel areas. It is the first true "universal" TV antenna. Makes better reception possible for practically every TV set-owner. And — for the first time — meets all antenna needs with a single antenna line!

UP TO NOW broad-band antennas have merely been piled-on conglomerations of narrow-band elements and parasitics, endlessly trimmed and modified to obtain maximum width without too great a quality loss. Such compromises are like teams of wild horses, each bent on pulling in its own direction. The assortments of parasitic elements lower the characteristic impedance of the antenna at the low end of each band, and make for signal-sapping standing waves and impedance mismatches.

BUT NOW — NO LONGER ANY NEED TO SACRIFICE QUALITY! Consisting of harmonically-resonant V-elements that operate on the log periodic cellular princi-

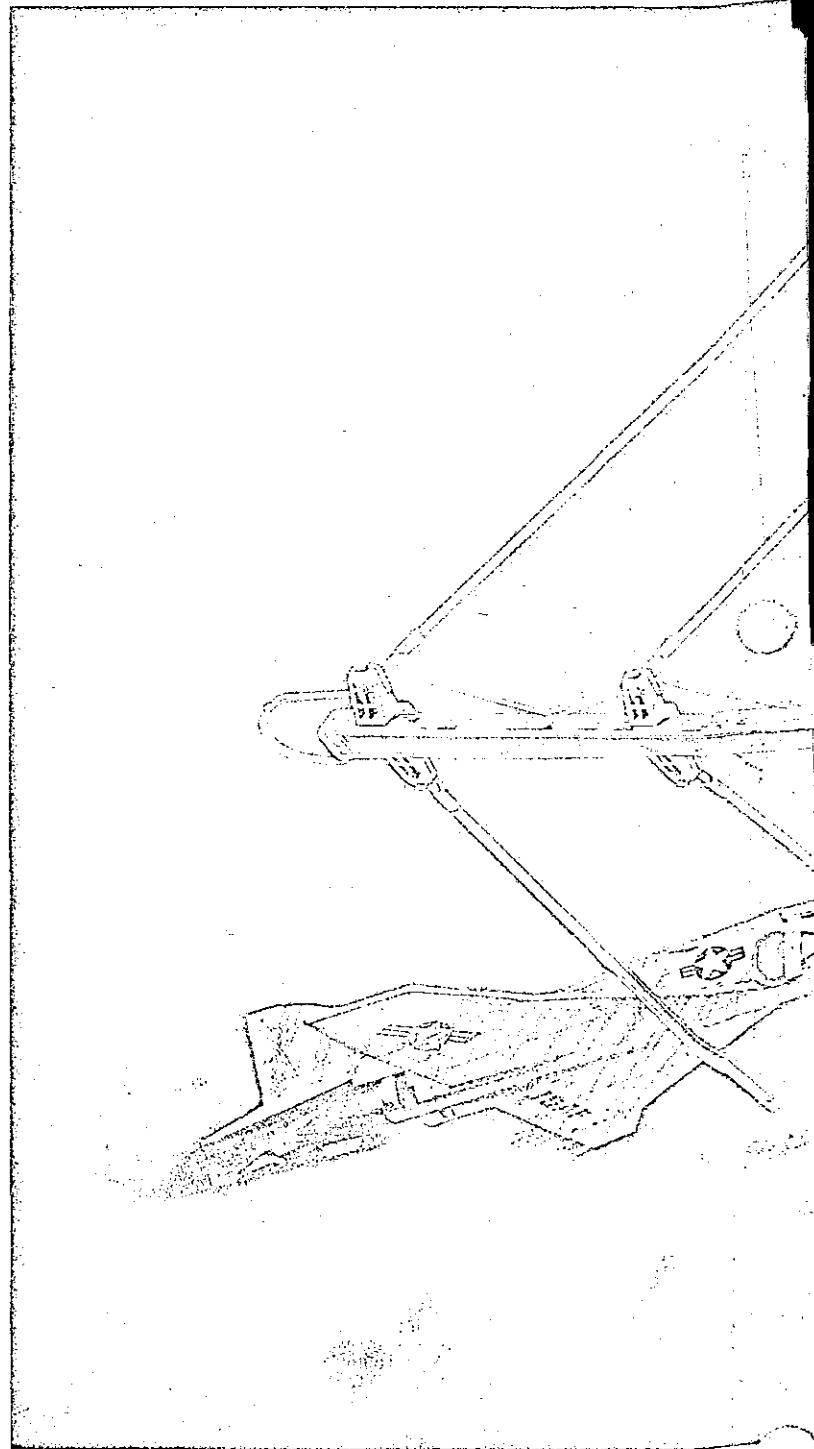

a new high-gain all-channel an

OS* Professor Paul Mayes of the Antenna
Research Laboratories of the University
of Illinois

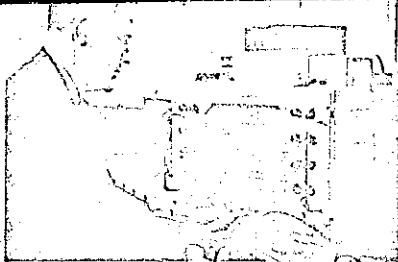

—PROVED-OUT IN

DIC $LPV \frac{L_{(n+1)}}{L_n} = \tau$ ENDS THE 'ERA OF COMPRO

U.S. PATENTS 2,958,081 — 2,985,879 — 3,011,168. ADDITIONAL PATENTS PENDING. PRODUCED EXCLUSIVELY BY JFD ELECTRONICS UNDER LICENSE TO UNIVERSITY OF ILLINOIS FOUNDATION

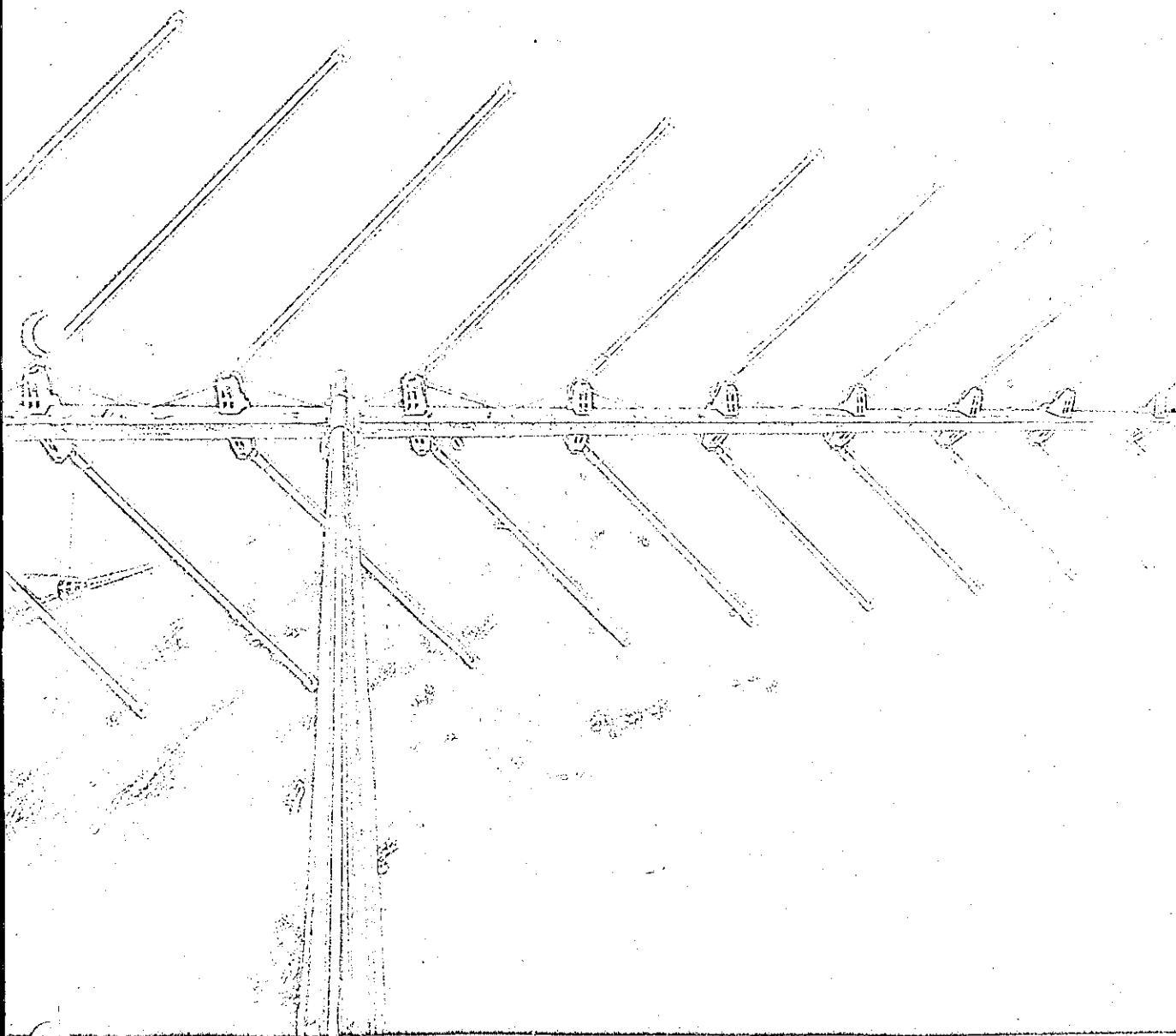

The LPV-11—for superior reception at ranges of up to 125 miles

enna comparable to a yagi across

AIR FORCE SATELLITE TELEMETRY- 'WISE' IN TV ANTENNA DESIGN

able in the fundamental and third harmonic modes, the LOG PERIODIC LPV is essentially frequency-independent. It was designed not as a catch-all compromise, but as an integrated unit with a total environmental design, all parts working together harmoniously. It literally receives all channels "best" — with optimum sharpness, clarity, freedom from snow and ghosts.

BEST FOR COLOR — BEST FOR BLACK-AND-WHITE — PLUS FM AND STEREO!

For full fidelity — in black-and-white as well as color — the relative amplitudes of the various signals must be reproduced in the receiver just as they were originated at the transmitter. The JFD LOG PERIODIC LPV is able to do this because it combines:

1. Sufficiently high gain to override set noise and provide a true, clear color picture.
2. Flat response. Gain variation of not more than 1 db. within 1.5 mc. below and .5 mc. above the color sub-carrier.
3. Narrow unidirectional polar pattern.
4. Close impedance match to help effect a low VSWR — to eliminate line reflections and transfer signal to downlead with maximum efficiency.

BASED ON PRINCIPLES DESIGNED TO MEET RIGOROUS AIR FORCE PERFORMANCE STANDARDS — BUILT TO UNCOMPROMISING JFD SPECIFICATIONS

Here's how the LPV tunes itself to each received frequency

1. Log periodic concept used in space communications antennas is basis for the LPV
2. Logarithmic scaling factor relates one element to the next, and makes an integrated antenna that "tunes" itself to each received frequency
3. Multi-element "cells" form along antenna for each received channel; high signal energy from each of the many dipoles in the cell adds up to high gain on each channel on both high and low TV bands and FM band
4. On high TV band, large LPV dipoles are three times wavelength of TV frequencies, "tune" to the third harmonic giving added gain
5. Forward V-ing of dipoles and crossed phasing harness give high front-to-back-ratio and directional sensitivity. Addition of directors optimizes the LPV on the high TV band

RESULT: High gain, high front-to-back ratio, and sharp directivity continuously from the lowest to the highest TV channel and including the FM band. A **BREAKTHROUGH IN TV ANTENNA DESIGN**

LPV CONSTRUCTION FEATURES

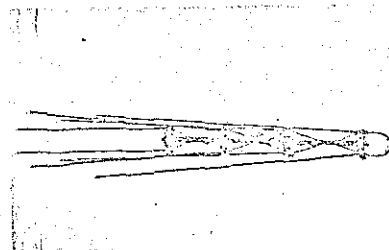

100% PREASSEMBLED FLIP QUICK CONSTRUCTION
Assembles in minutes.
Simply click elements into position.
No bulky or complex dipoles to fumble with.

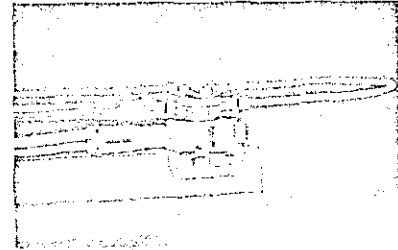

ONE INCH SQUARE ALUMINUM CROSS ARM
Extra heavy gauge aluminum boom provides strength and durability never before available in TV antennas. Poly-plug ends keep out water—prevent wind whistle.

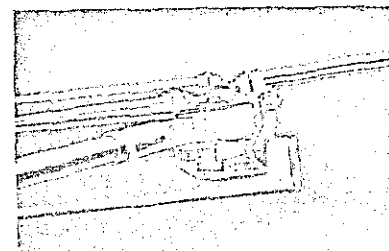

OVERSIZED "TANK-TURRET" BRACKET
Radical new circular spring lever bracket double-locks elements in place yet swings smoothly and effortlessly into position.

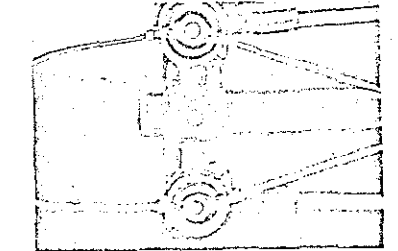

SLEEVE RE-INFORCED ELEMENTS
Heavy-wall insert reinforces every element at vital bracket connections. Prevent accidental bending... keep element alignment straight and true.

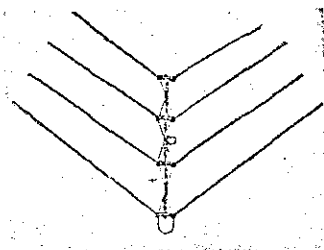

LOWEST WIND RESISTANCE OF ANY ANTENNA
The VEE-angulated presents least possible area to wind, ice or snow.

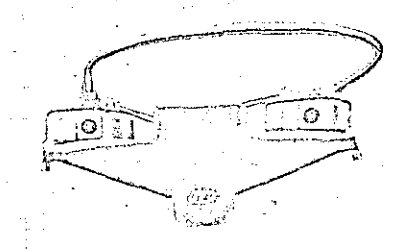

MASSIVE NEW WEATHER-PROOF INSULATOR.
Designed to drain off water. Elevated center barrier prevents shorting of signal from possible rain, dirt or snow accumulation.

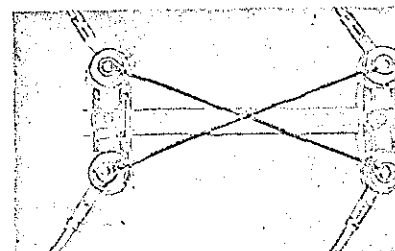

SOLID ALUMINUM ROD HARNESS
No troublesome matching harness because there is no impedance mismatch to correct. Log-Periodic design replaces crude harness with transposed high-Q phasing bars. Harness is made of indestructible 1/2" o.d. solid aluminum rod cold welded to lugs for permanent performance.

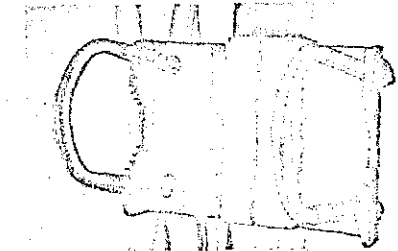

DOUBLE U-BOLT ASSEMBLY
Rugged oversized tandem U-bolt locks antenna to mast, increases structural strength.

the entire band

why the LPV makes all other antennas obsolete

how the Log Periodic LPV works

Developed to formula and not by chance—the one unique design and principle of the Log Periodic LPV solves all antenna needs...

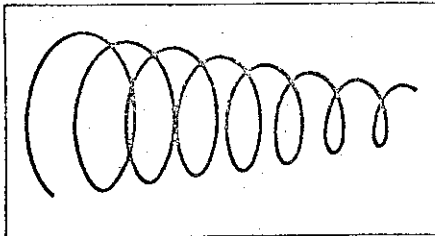

The JFD LPV antenna is a direct descendant out of the logarithmic conical spiral antenna used on the Transit satellite. This basic design is **FREQUENCY INDEPENDENT**—it works like a conical waveguide to yield almost constant gain, matched impedance and a unidirectional polar pattern across an extremely wide band of frequencies.

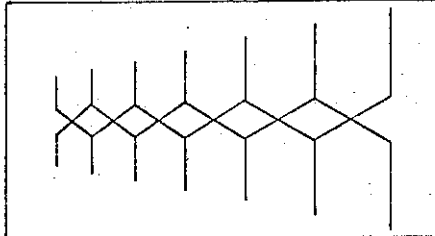

Dipole version of spiral antenna has elements whose length and spacing is determined by formula derived from conical spiral geometry, so that antenna acts like a spiral with parts of coils missing. A logarithmic scaling multiplier ties the dipoles together into active multi-element cells for each frequency. Crossed phasing harness inserts a 180 degree phase shift between dipoles that cancels signals from rear, reinforces signals from front.

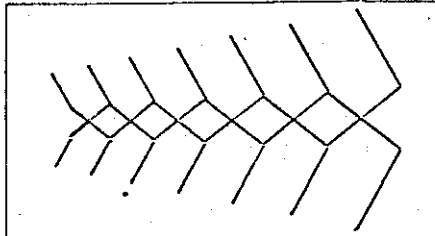

JFD's LPV antenna for TV and FM goes one step further—increases gain and front-to-back ratio while maintaining frequency independence. Forward V-ing of elements shrinks rear radiation lobes, narrows forward beam for sharp directivity, helping to eliminate ghosts and adjacent channel interference. Forward V also permits low band dipoles to contribute to high band gain by operating on the third harmonic mode.

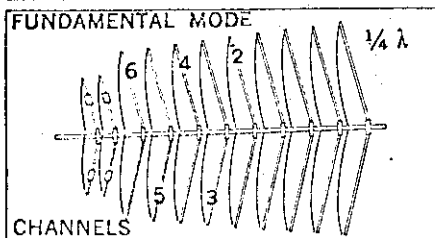

For example: Operation of the JFD LPV-11 on the low band: The larger dipole cells resonate to the low band TV frequencies at their fundamental wavelength. Within each cell, one dipole absorbs the greatest amount of signal for any particular channel, adjacent dipoles pull in 60% more and the next two dipoles add 30% more signal. Many active dipoles working on each channel with constant impedance guarantee high gain.

— indicates current distribution on fundamental mode

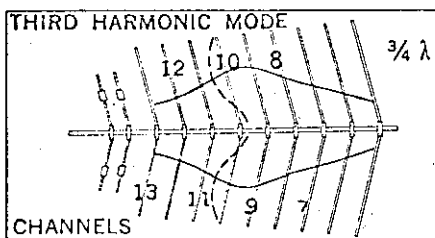

On the high band: The third harmonic cell forms at the rear of antenna for channel 7 and as the frequency increases toward channel 13, the active region moves toward the apex of the antenna. It is this third harmonic operation which guarantees as much as 3 1/4 db. additional gain. Continuous and co-linear directors sharpen forward pattern and give peak performance across the entire VHF TV band.

--- indicates the current distribution for the third harmonic mode which will be received on all elements.
 — indicates the active region for channel 10, i.e., the different efficiencies with which the elements of the LPV-11 act on channel 10.

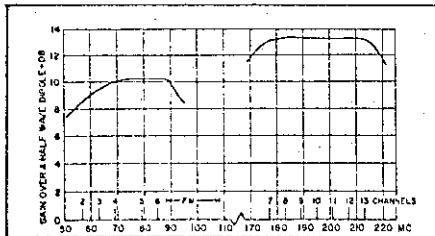

The actual gain curves measured for the LPV-11 in the JFD Antenna Research Laboratories confirm this fact: Within the band for which it is designed (the principle will also be adapted for UHF and other uses), the log periodic LPV's impedance, polar patterns and front-to-back ratio are virtually constant—with gain for each channel as high as that furnished by a comparable-sized single-channel Yagi.

Each antenna in the LPV series consists of an array of resonant V-dipoles and crossed phasing bars, constituting a group of "cells." The size of each cell differs from the one before it by a Logarithmic factor. For any particular frequency, the active portion of the antenna centers on the resonant dipole (equal to one-half wavelength at that frequency), with the adjacent elements also absorbing significant signal energy. The resonances of adjacent cells overlap, so that as the frequency increases or decreases, it is transferred smoothly from one cell to the next.

In effect, the signal is passed along as the frequency increases—the active area moving toward the apex or small end—until, as the fundamental harmonic reaches one end, the other end approaches resonance in the third harmonic. Conventional wide-band antennas are like rows of compartments, one for each channel desired, with sharp cutoffs. The log periodic antenna is like a continually moving belt that accepts smoothly any frequency that hops aboard.

sign equations. This scientific approach is in marked contrast to the methods used hitherto.

Therefore, the JFD LPV antenna is so effective on the low TV band because: 1) there are a large number of elements working on every channel, and 2) the signal absorption efficiency of each dipole in the active cell is extremely high because of its low impedance at the received frequency. Another contributing factor is the high directionality of the LPV, but this will be gone into later.

High Band Operation

As the received frequency increases, that is, for channels 7 through 13. However, now the large elements at the rear of the antenna constitute 3/2-wavelength dipoles and resonate at the received frequency in the third harmonic mode. This contributes significant signal absorption at the higher VHF frequencies and increases antenna gain in these channels. The actual amount of gain realized by third harmonic operation is shown in Figure 4, the VHF gain curves for the JFD LPV-11, an eleven element antenna. From these curves we see that

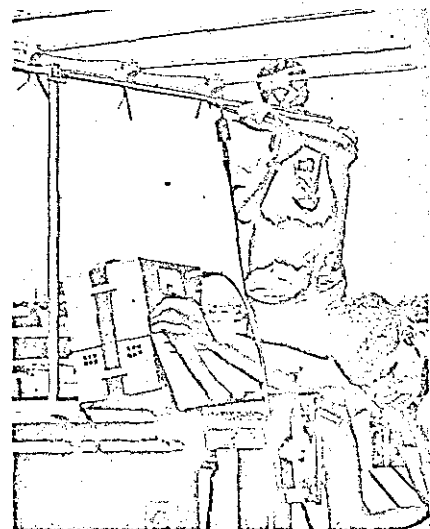

JFD engineers testing frequency-independent characteristics of one of the many LPV prototypes

there is an average increase of 3 1/4 db in gain on the high VHF band versus the low band. The active region once again moves forward as the frequency increases.

Good TV reception requires that an antenna furnish higher gain on the high VHF band than on the low band. Propagation tests made by TV broadcast engineers indicate, and actual home TV reception has proven, that high TV band signals suffer greater signal loss with distance than do low band signals. Therefore, to receive high band stations satisfactorily, more gain is required of the antenna. This the JFD LPV antenna supplies as an inherent fact of its operation.

A close inspection of Figure 4 shows that the gain of the JFD LPV-11 (and this is typical of all antennas in the LPV series) is uniform across all channels on the low band, and higher but also uniform across all channels on the high VHF band, falling slightly at channel 13. This characteristic,

of course, is because the antenna is frequency independent, but even more important relative to color TV reception, is the fact that it guarantees that all components of a composite transmitted color TV signal will be received intact. For full color fidelity, it is essential that the relative amplitudes of the various color signals be duplicated in the receiver as they were originated at the transmitter. Obviously this can only hold true if the antenna has a flat gain and phase response for the entire channel.

Constant Impedance

Of particular importance relative to gain, is the characteristic impedance of the antenna, and the closely allied factor, voltage standing wave ratio (VSWR). If the impedance of the antenna varies appreciably from that of the transmission line at any point in the band pass of the antenna, a mismatch will exist between the antenna and the download. Such a mismatch will decrease signal power to the set and introduce standing waves along the line leading to further signal reduction and ghosts. The LPV antenna is unique in that it maintains essentially constant impedance across the full bandwidth of the antenna. This could be attributed to the impedance balance maintained by the active region of the antenna, with relation to the complete antenna. For the active region, the impedance of the antenna is low, making for high transfer efficiency from the elements to the feedline. At the inactive regions, (inactive, that is, for that particular frequency) the impedance is high. The total impedance presented to the transmission line, however, is always relatively the same.

Voltage standing wave ratios for the LPV have been measured as low as 1.2 to 1. Such low VSWRs are typical of log periodic antennas and derive from correct scaling of the cells and the constant impedance characteristics.

We see, therefore, that the LPV configuration does indeed maintain a nearly constant gain, impedance, and VSWR over its com-

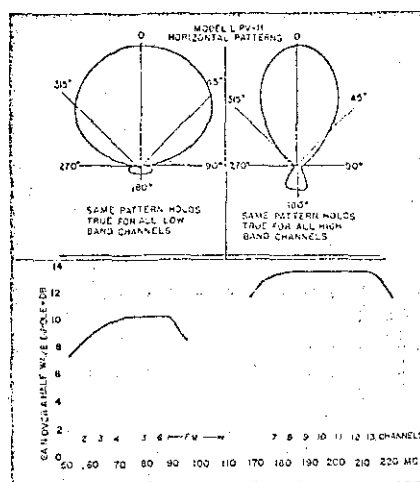

Figure 4

plete bandwidth. Rather than serving as a limited group of pigeonholes that accept discrete frequencies (or channels) with sharp cutoffs, the LPV antenna is like a continually moving belt, accepting smoothly any frequency that hops onto it. The fact that these reception characteristics can occur

on an antenna as small as the LPV, the fact that a bandwidth spread of ten to one can occur at all, is due to the logarithmic relation of the elements.

Directivity, High Front-To-Back Ratio

As important as high gain and constant impedance are in fringe area reception, the antenna would be worthless without good directional sensitivity. Even in the heart of cities, good directional response is necessary to reject the ghost-causing interference signals that bounce from building to building. In fringe areas, interfering signals from adjacent channels and other sources, picked up by the antenna from the rear and sides, cause venetian blind effects, herringbones, fading, ghosts and other picture distortions.

Yagi antennas obtain good directivity and high front-to-back ratios by the use of parasitic elements—directors and reflectors for a sharp forward pattern. The LPV antenna obtains its sharp forward response pattern from its periodic structure and the V-ing of the elements.

Consider Figure 5, which is a simplified diagram of a four-cell LPV antenna, front-fed, and using a twisted phasing harness. (For purposes of this explanation we will consider the antenna as a signal transmitter, however, the same effect holds true in reception.) Note that because the elements of the adjacent dipoles are not fed in parallel, they are in phase opposition. This effectively cancels radiation to the rear. Furthermore, the length of the harness plus the air space between adjacent elements adds up to produce a 360 degree phase shift between the signals radiated from the first and second elements (or between any two adjacent elements) in the forward direction, i.e., in the direction of the feedline. A 360 degree phase shift actually puts both radiated waves in phase for additive signal strength.

In the reverse direction, that is, toward the rear of the antenna, the story is quite different. Now the fact that the harness is crossed, introduces a 180 degree phase shift in the signal path between adjacent elements, putting the radiation from them out of phase in the backward direction.

Naturally, because of the log periodic factor, the spacing between elements on the LPV antenna is not constant, and neither are the lengths of the various harness bars. These variations, however, conform to the variations in wavelength across the TV band so that within any active cell the spacing is correct to produce the required phase shift. In actual production, to optimize the phase shift effect, JFD engineers have changed the lengths of the elements slightly to make them either slightly inductive or capacitive at the required signal frequency, introducing a phase lead or lag. Operating within the cell, and in combination with the phasing bars, this results in the required constant phase shift to produce a backward wave toward the feedline.

Additional directional sensitivity in the higher frequency band, where it is needed most, is obtained by V-ing the elements forward. A straight half wave dipole receiving a signal three times its resonant

6 JFD log periodic LPV $\frac{1}{L_n} \tau$ TV antenna FOR CAMERA-LENS SHARPNESS IN EVERY LOCATION

harmonically-resonant V-elements operating on the log periodic cellular principle in the fundamental and third harmonic modes—best for color, best for black and white.

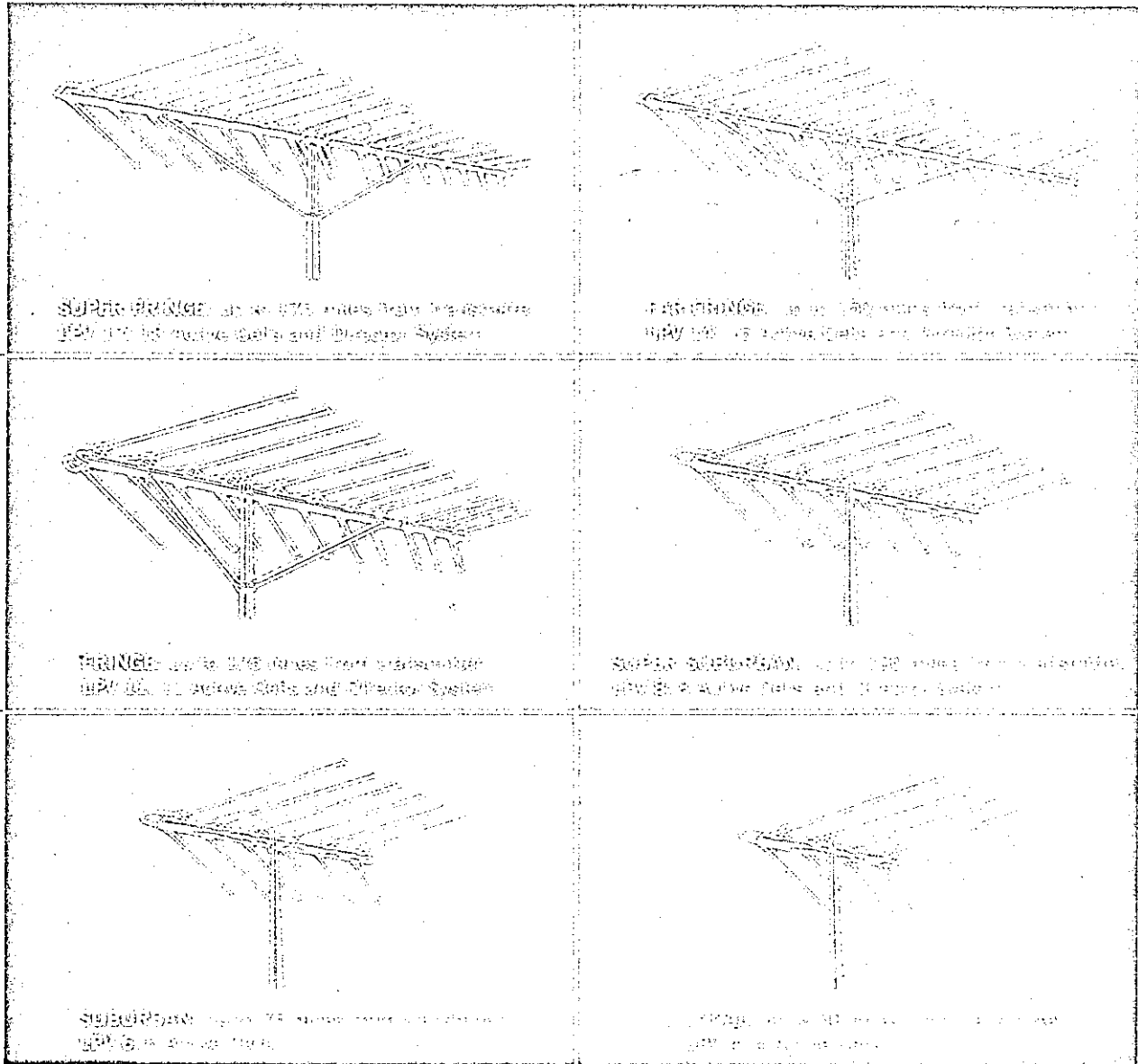

AAA* GOLD BOND ALODIZED satin gold finish protects against atmospheric corrosion, assures enduring good looks EXTRA-RUGGED IN EVERY DETAIL with new "tank-turret" aluminum brackets that align and double-lock elements permanently in place ... 1" square aluminum crossarm ... solid aluminum rod harness ... sleeve-reinforced elements that prevent accidental bending, keep alignment true **LIGHTEST IN WEIGHT PER DB. GAIN** ... least wind resistance of any antenna **BEST FOR COLOR, BEST FOR BLACK-AND-WHITE—FM and stereo, too!**
*Attractive, Anti-corrosive Armor

JFD

JFD ELECTRONICS CORPORATION
15th Avenue at 62nd Street, Brooklyn 19, N.Y.

JFD Electronics-Southern Inc., Oxford, North Carolina
JFD International, 15 Moore Street, New York, N.Y.
JFD Canada, Ltd., 51 McCormack Street, Toronto, Ontario, Canada
401-144 West Hastings Street, Vancouver 3, B.C., Canada

SEE IT NOW

X B 3 4

JFD

JFD ELECTRONICS CORP.

RECEIVED

OCT 6 1964

October 5, 1964

MERRIAM, SMITH & MARSHALL

University of Illinois Foundation
University of Illinois
Champaign, Illinois

Attention: Mr. James Colvin

Re: Copy Clearance for
LPV Antennas

Dear Jim:

Here is a listing of the phrases used in the last category,
JFD Product literature.

4. JFD PRODUCT LITERATURE

Brings the acknowledged Log-Periodic design of the
Antenna Research Laboratories of the University of
Illinois to a new peak of performance.

The Log-Periodic concept is the result of five years
of intensive electronic studies at the Antenna Research
Laboratories of the University of Illinois and JFD.
Located in Champaign, Illinois (home of the University
of Illinois), the vast new JFD research center is the
largest and most complete of its kind.

Adapted from the Antenna Research Laboratories of
the University of Illinois.

The first UHF antenna design based on the patented
Log-Periodic LPV formula of the Antenna Research
Laboratories of the University of Illinois.

LPV...from the Antenna Research Laboratories of
the University of Illinois.

JFD

JFD ELECTRONICS CORP.

October 5, 1964

Mr. James Colvin (Cont.)

4. JFD PRODUCTS LITERATURE (Cont.)

The first TV/FM antenna based on the geometrically-derived Logarithmic-Periodic scale developed by the Antenna Research Laboratories of the University of Illinois for satellite telemetry.

Soon! From the Antenna Research Laboratory of a Leading University a mathematical dream becomes an engineering reality.

Designed according to the revolutionary new log periodic antenna formula of the Antenna Research Laboratories of the University of Illinois.

The first UHF antenna adapted from the patented Log-Periodic LPV formula of the Antenna Research Laboratories of the University of Illinois.

Developed by the University of Illinois Antenna Laboratory-now serving in Satellite Telemetry-Adopted to TV by JFD.

Significant New Principles Developed for Satellite Tracking, Space Telemetry and Military Communications by University of Illinois Antenna Research Laboratory lead to new High-Gain All-Channel Antenna "Comparable to a Yagi Array" across the entire band.

Conceived by the University of Illinois*....
Proved-Out in Air Force Satellite Tracking....
Licensed and Developed for Home Use by
JFD Electronics....

JFD

JFD ELECTRONICS CORP.

Mr. James Colvin (Cont.)

4. JFD PRODUCTS LITERATURE (Cont.)

Created by the Antenna Research Laboratories of
the University of Illinois*-
Principles Utilized in Air Force Satellite Tracking
and Telemetry-
Exclusive from JFD Electronics-

Again, would you please review them and let me know
which we may continue to use for the future.

I take this opportunity to thank you for your patience
and cooperation in resolving this problem.

Sincerely,

Ed Finkel

EF/ss
cc-S. Faber
S. Smith

A00348

XB35

UNIVERSITY OF ILLINOIS FOUNDATION

October 14, 1964

Mr. Ed Finkel
JFD Electronics Corporation
15th Avenue at 62nd Street
Brooklyn, New York 11219

Dear Ed:

*File
Foundation AFU
10/14/64*

I meant to answer your October 5 letter before this but I wanted to check the statements with both Professors Jordan and Mayes and they have been very much involved in an Electrical Engineering meeting this week which kept me from getting together with them.

I am sending you the combined opinion of Mr. Jordan, Mr. Mayes and Mr. Samuel B. Smith, in which I concur.

Page 1 of your letter, paragraph 1 is satisfactory.

We ask that you eliminate paragraph 2. I think it can be rephrased but Mr. Jordan objects to it because it indicates that the entire research program was designed for the benefit of JFD. Why don't you try this one over again?

Paragraph 3. Would you please change it to read, "Adapted from research results of the Antenna Laboratory of the University of Illinois."

Paragraph 4. This is troublesome because of the use of the word "patented" and Mr. Smith tells me there are legal reasons why this should not be used.

Paragraph 5. We should like you to change it to read, "LPV -- is designed from the Antenna Research Laboratory of the University of Illinois." The reason we suggest this is that, originally worded, it implies that the Foundation is in the manufacturing business.

Page 2, paragraph 1. We should like to have it changed to read, "The first TV/FM antenna based on the geometrically-derived Logarithmic-Periodic scale developed by the Antenna Research Laboratories of the University of Illinois and used in satellite telemetry."

Paragraph 2. We ask you not to use this one. It is good advertising copy. I think it could be rewritten and modified.

Paragraph 3 is satisfactory.

A00349

RECEIVED
OCT 15 1964
MERRIAM, SMITH & MARSHALL

October 14, 1964

Paragraph 4 is untrue. The Log-Periodic LPV formula is not patented. Patents are issued only on the structure which was based upon the principle covered by the formula. This paragraph seems objectionable from a legal standpoint. Why don't you rewrite it and resubmit?

Paragraph 5 is satisfactory.

Paragraph 6. We should like to have rewritten as follows:
"Significant New Principles Developed by the University. . . .etc."

Paragraph 7 is not true. It wasn't the University which conceived the idea but the people in the Antenna Laboratory. You may want to resubmit a paragraph similar to this.

Page 3. The paragraph on this page is satisfactory.

Best regards!

Cordially yours,

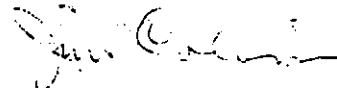

James C. Colvin
Executive Director

JCC:pw

cc: Mr. Samuel B. Smith

A00350

B 37

Two supercapacitors for LPV Antennas give you tremendous reception on both VHF and UHF channels.

Each element double station-pulling power of the elements to give you photo-sharp black-and-white pictures... lifelike color. And, you get superb FM/FM stereo with the 3 smallest sizes (15 and 18-element sizes not designed for FM). Gold-color alodined finish resists power-robbing corrosion. Boom bracing on 15 and 18-element sizes. Preassembled.

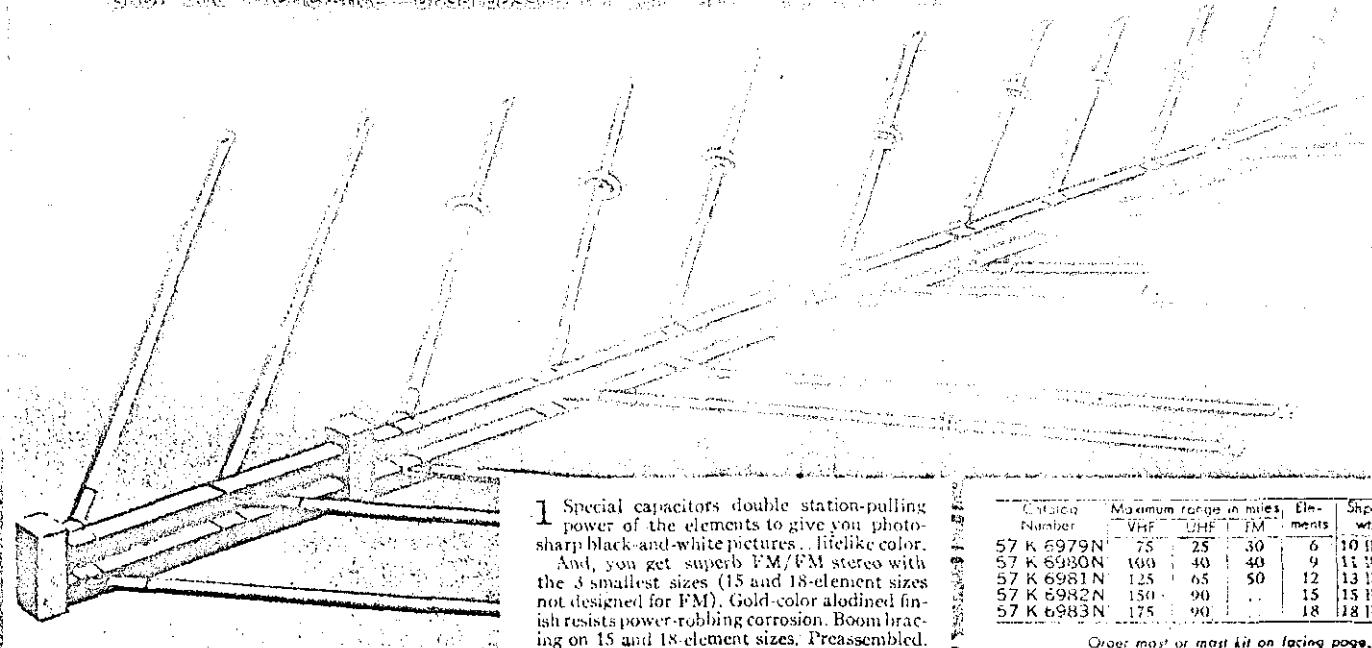

1 Special capacitors double station-pulling power of the elements to give you photo-sharp black-and-white pictures... lifelike color. And, you get superb FM/FM stereo with the 3 smallest sizes (15 and 18-element sizes not designed for FM). Gold-color alodined finish resists power-robbing corrosion. Boom bracing on 15 and 18-element sizes. Preassembled.

Catalog Number	Maximum range in miles			Elements	Shpg. wt.	Price
	VHF	UHF	FM			
57 K 6979N	75	25	30	6	10 lbs.	\$29.95
57 K 6980N	100	40	40	9	11 lbs.	37.95
57 K 6981N	125	65	50	12	13 lbs.	37.95
57 K 6982N	150	90	..	15	15 lbs.	44.95
57 K 6983N	175	90	..	18	18 lbs.	52.95

Order mast or mast kit on facing page.

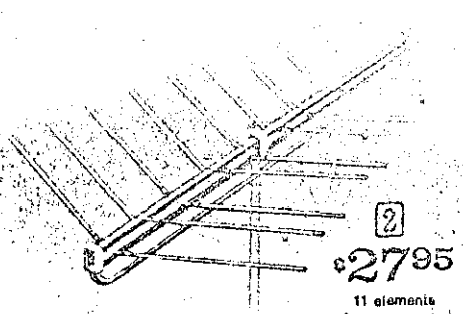

2 \$27.95
11 elements

Get superb color or black-and-white reception on all VHF channels

2 Improved to block out ghosts, snow and interference as well as our all-channel antenna. For black and white or color... plus FM on all but 3 largest sizes. Gold-color alodined finish. Pre-assembled. No boom bracing on first 3 sizes.

Catalog Number	Range, miles		Elements	Wt. lbs.	Price
	VHF	FM			
57 K 6602N	50	30	4	7	\$9.95
57 K 6603N	75	40	6	11	14.95
57 K 6604N	100	50	8	12	19.95
57 K 6605N	125	50	11	22	27.95
57 K 6606N	150	..	14	25	34.95
57 K 6607N	175	..	17	28	44.94
57 K 6608N	200	..	18	31	54.95

*Allow 10 lbs. postage (postal regulations).

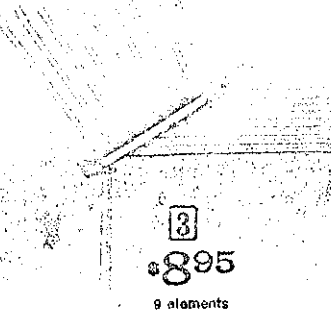

3 \$8.95
9 elements

Great color or black and white on all UHF plus VHF channels 7 to 13

3 Pinpoints hard-to-get stations in cluttered city or hilly areas because it is extremely directional. And, gives you 30% to 50% more station-pulling power than ordinary UHF antennas. Gold-color alodined finish resists corrosion that can gradually rob you of clear, sharp pictures. Elements are solid aluminum.

For easier installation, it's preassembled... elements just fold out.

Catalog No.	Max. range	Elements	Wt. lbs.	Price
57 K 6973L	25 miles	5	5	\$5.50
57 K 6974L	40 miles	9	10*	8.95
57 K 6975N	60 miles	15	7	13.95
57 K 6976N	80 miles	21	9	18.95

Order mast or mast kit for (2), (3), (4), (5) from facing page.

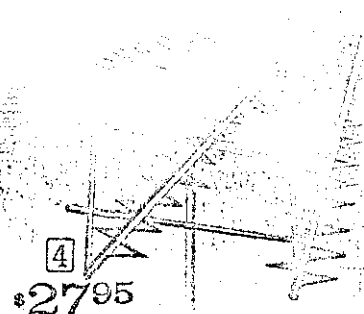

4 \$27.95

Zagy UHF Antennas for long range color or black-and-white reception

4 Up to 90 miles range. Special LPV design performs huge parabolic-dish antennas... you photo-sharp pictures even in far-fragile areas.

Gold-color alodined finish resists corrosion. Unprotected antennas of station-pulling power. Preassembled. \$4 monthly.

57 K 6986L—Shpg. wt. 5 lbs. Cash \$27.95

5 Up to 60 miles range. Same LPV design as antenna above for good reception on widely spaced stations. Outperforms 4-bay bow-tie screen antennas. Corrosion-resistant gold-color alodined finish. Shipped completely assembled. 57 K 6985L—Shipping weight 4 pounds... \$12.95

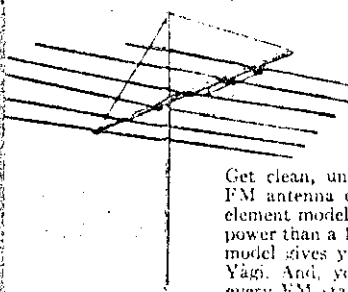

LPV Antenna for FM/FM-stereo radio \$15.95 6 elements

Get clean, undistorted reception no ordinary FM antenna can equal. Here's proof: our 10 element model delivers up to 58% more signal power than a 10-element Yagi... our 4 element model gives you the reception of a 6-element Yagi. And, you get the same great power on every FM station. Gold-color alodined. Boom bracing on all but 57 K 6719N. Preassembled. Order mast, opposite page.

Catalog Number	Maximum range	Elements	Wt. lbs.	Price
57 K 6719N	75 miles	4	5	\$9.95
57 K 6720N	125 miles	6	6	15.95
57 K 6721N	180 miles	8	8	29.95
57 K 6722N	175 miles	10	9	39.95

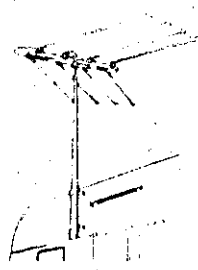

Mobile home VHF-UHF Antenna Kit \$9.95

LPV design gives you 50-mile range on VHF... 30 miles on UHF. Gold color alodined finish resists signal-robbing corrosion.

Frame mount... permanently... antenna and upper mast slide out and fold for travel. Aluminum with aluminum plated hardware. Mast is 6 ft. aluminum. 25 lb. lead in wire shipped partially assembled. 57 K 6929L—Allow 10 lbs. postage... \$9.95



VHF Antenna... 35-mile range \$9.95

Conical type. Gold color alodined aluminum. Preassembled. Order mast, opp. page. 57 K 6911L—Allow 10 lbs. postage... \$9.95

Like above but single bay... lower mast. 57 K 6910L—Allow 10 lbs. postage... \$5.30

SHIPPING NOTE FOR BOTH PAGES: "N" items (as 57K6979N) sent by rail (rail or truck) or express.

DEFENDANT'S
EXHIBIT

1338

WINGAD - BOSTON, N. J.

$34 \frac{13}{16}$

13

11

2

8

CENTER LINE
OF RIVET

* ELEMENT LENGTH

32.5°

LT. TURB
COL. OF. 100

LT. TURB

LT. TURB

$1 \frac{1}{2}$

$13 \frac{17}{32}$

$13 \frac{9}{32}$

13

$67 \frac{9}{16}$

A
B
C
D
E
F
G
H
I
J
K
L
M
N

1 2 3 4 5 6 7

0
1
2
3
4
5
6
7
8
9
A
B
C
D
E
F
G
H
I
J
K
L
M
N
O
P
Q
R
S
T
U
V
W
X
Y
Z

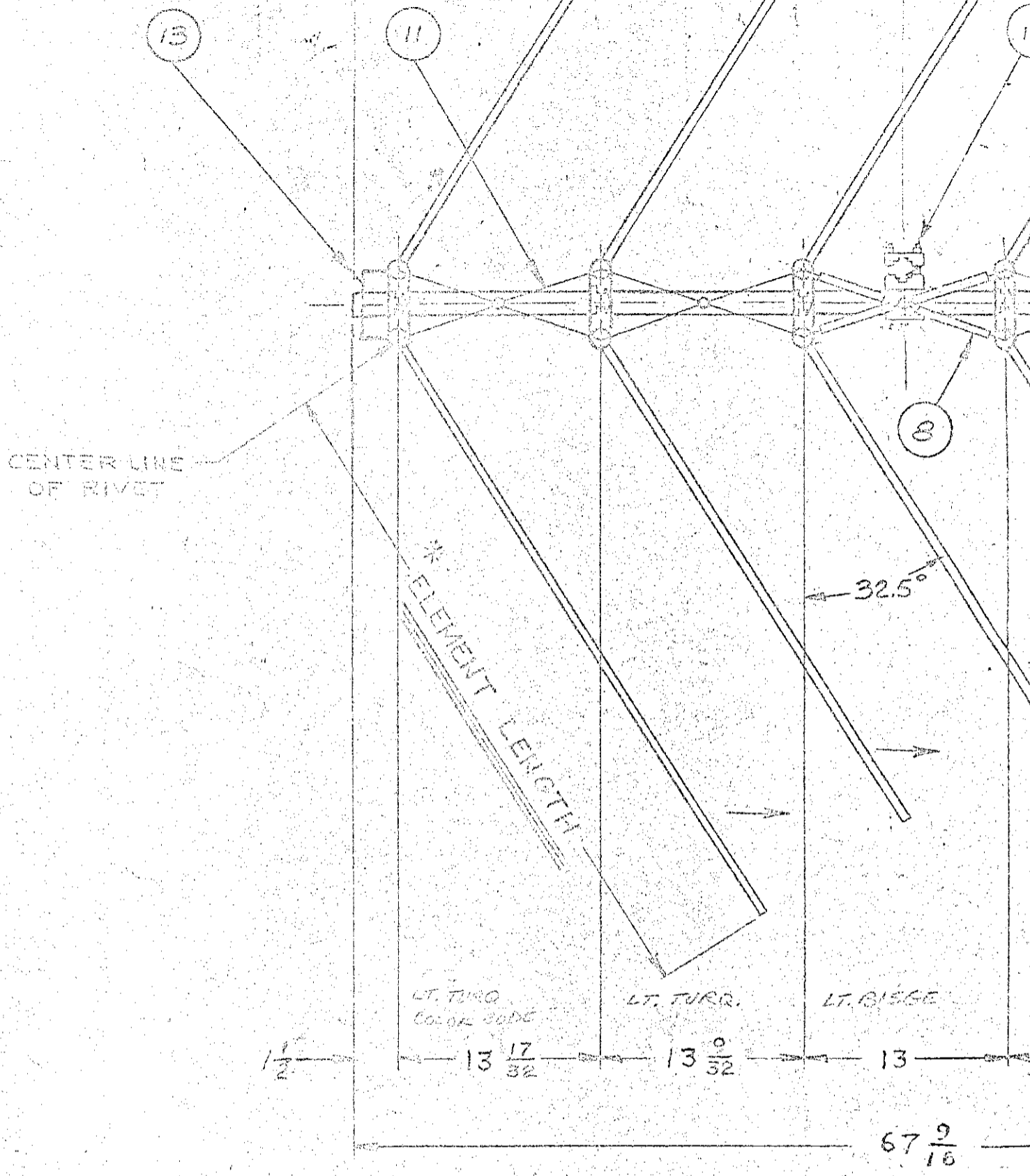

NOTE:

- 1-TAKE OFF AT BOTTOM OF INSULATOR "X X"
- 2-CARTON SIZE IS $6\frac{3}{4} \times 4\frac{3}{4} \times 71$ "
- 3-INDICATED FOLDING ACTION OF EL.

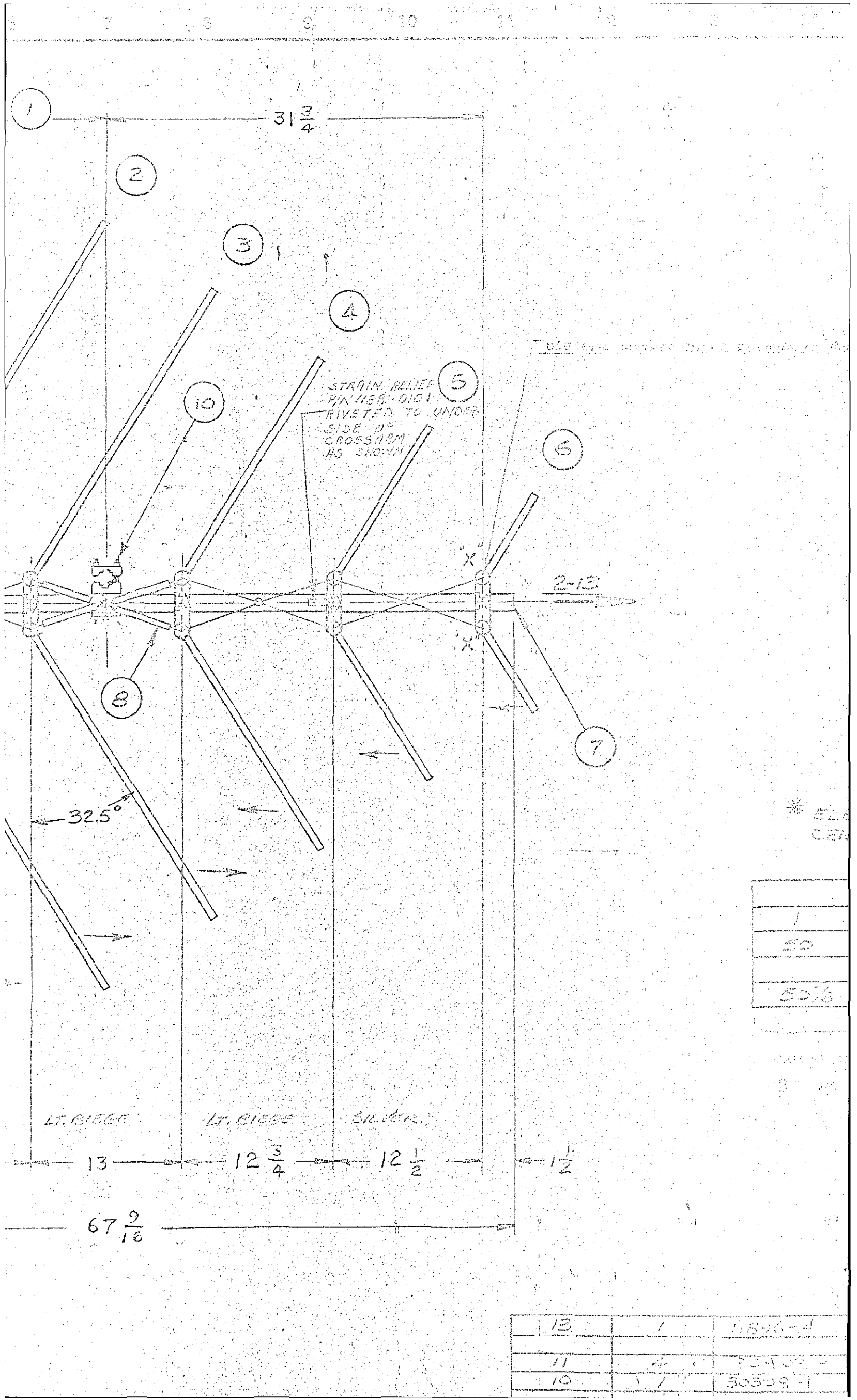

* ELA
CEN

1
50
50%

13	1	11896-4
11	4	23408-
10	1/2	50308-1

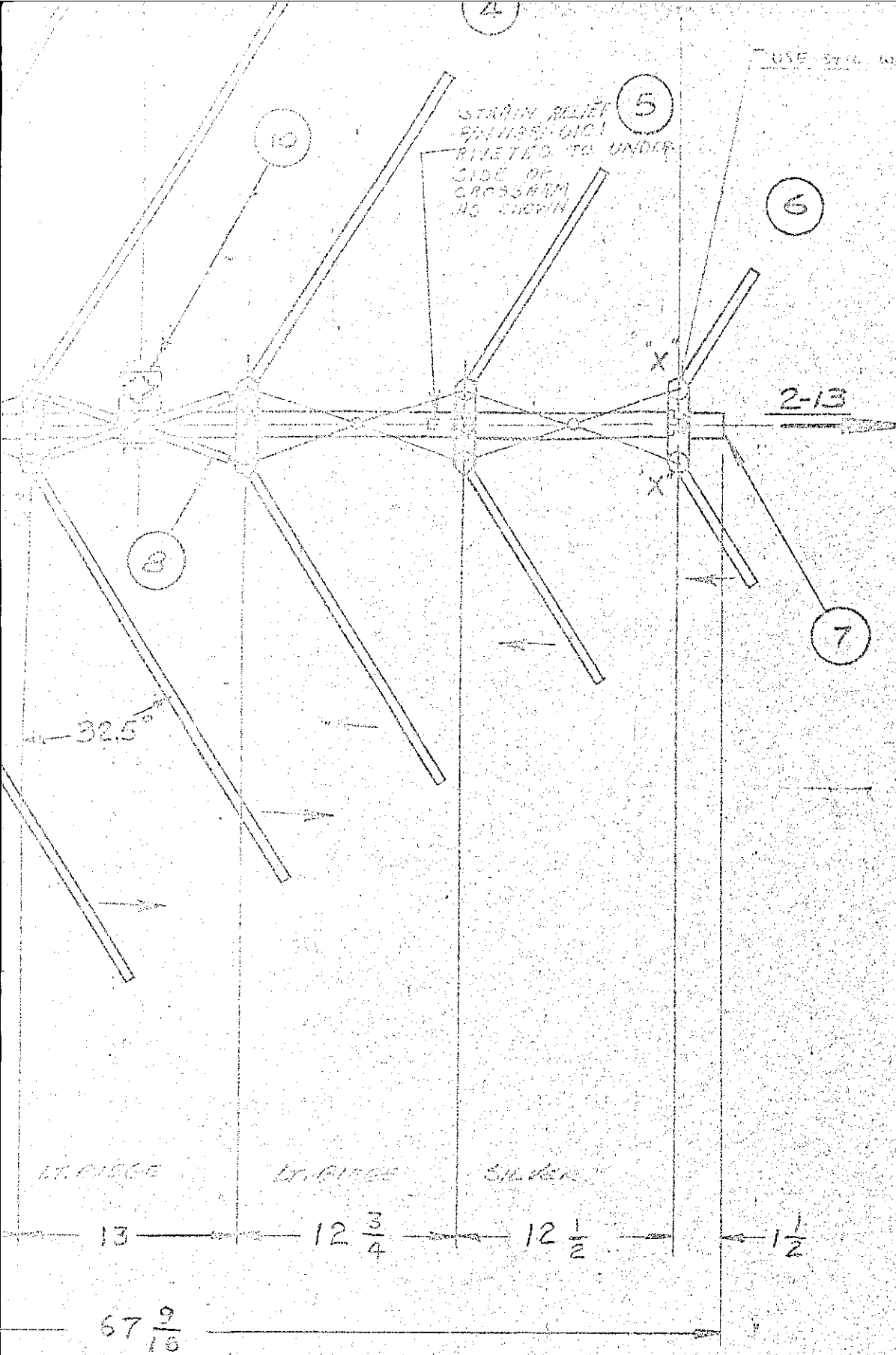

* ELEM
CENT

1	
50	
50%	

only 7
8" 49"

11.01566

12.01566

12.01566

13 12 $\frac{3}{4}$ 12 $\frac{1}{2}$ 1 $\frac{1}{2}$

67 $\frac{9}{16}$

13	1	11896-4
11	4	30407-
10	1	30398-1
8	1	30407-
7	1	12036
1 TO 6	12	11833-
ITEM NO.	NO. REQ'D	PART NO.
SCALE:	NONE	TOLERANCES UNL OTHERWISE SPEC
NO. REQ'D PER ASSEMBLY:	~	FRACTIONAL ± 1/ DECIMAL ± 0. ANGULAR ± 1'
MATERIAL:	~	
HEAT TREAT:	~	
FINISH:	GOLD ALODINE	

71
VAN

REV.	DESCRIPTION	DATE	BY
A	1/2" DIA. U-BOLT ASSEMBLY		
B	3/8" DIA. U-BOLT ASSEMBLY 41" LENGTH 41-1/4"		
C	WELD ASSY W/IN PROVISION TO 30205-A AND OTHER		
D	3/8" DIA. U-BOLT ASSEMBLY		
E	CHANGED HARNES TO 30205 3/8" DIA. THE LEGS OF SHALL BE STAMPED W/IN PROVISION		
F	MODIFIED SPACINGS, CES CROSS ARM POINT.		
G	3/8" DIA. U-BOLT ASSEMBLY		
H	WELD ASSEMBLY TO 30205 OF EL.		
I	STRAIN RELIEF NOTE ALONG		

REVISED AS SHOWN

SHORTING STUB
ITEM (13)

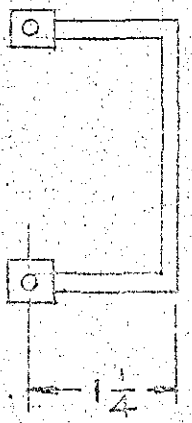

* ELEMENT LENGTH MEASURED FROM
CENTER OF RIVET TO END OF ELEMENT

ELEMENT LENGTH (ONE SIDE)					
1	2	3	4	5	6
50	46 1/8	41 3/4	34 3/16	29	24 1/2
ELEMENT CUT SIZE					
50 7/8	47	42 3/8	35 1/16	29 1/2	25 3/8

ONLY THESE ELEMENTS TO USE
8" LG. U-BOLT ASSEMBLY 30205-08

11896-4	SHORTING STUB 1/4 LG.
30402	HARNES ASSY
308-1	DOUBLE U-BOLT ASSY

- C. ALL DIMENSIONS UNLESS OTHERWISE SPECIFIED
- H. ARROW SHOWS TOLERANCE LIMITS TO BE USED
- I. DRAWN RELIEF NOTE (IDDEN) 1-26-62

SHORTING STUB
ITEM (5)

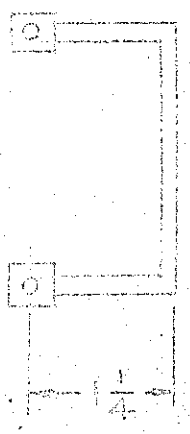

* ELEMENT LENGTH MEASURED FROM CENTER OF RIVET TO END OF ELEMENT

ELEMENT LENGTH (ONE SIDE)					
1	2	3	4	5	6
50	46 1/8	41 3/4	34 3/8	29	24 1/2
ELEMENT CUT SIZE					
50 3/8	47 1/8	42 3/8	35 1/8	29 1/8	25 3/8

11396-4	SHORTING STUB 1/4 LG.
30403 -	HAIRNESS ASSY
30308 -1	DOUBLE U-BOLT ASSY
20401 -	HAIRNESS ASSY
12026	CROSSARM SQ.
11833-	ELEMENT

TOLERANCES UNLESS OTHERWISE SPECIFIED FRACTIONAL ± 1/64 DECIMAL ± .005 ANGULAR ± 1/2°	LPV-6L				DATE OF PRINTING
					OCT 18 1966
					NEXT ASSEMBLY
					DRAWING NO.
DRAWN		CHECKED		ENG. APP.	PROD. APP.
10-10-62		10-12-62			
JFD ELECTRONICS CORP. BROOKLYN, N. Y.					50451

O
U
N
E
G
H
L
K
L
M
N
R

BOTTOM ROOM

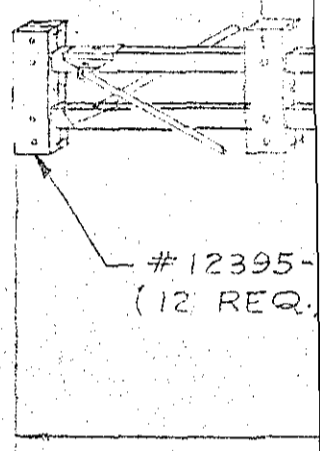
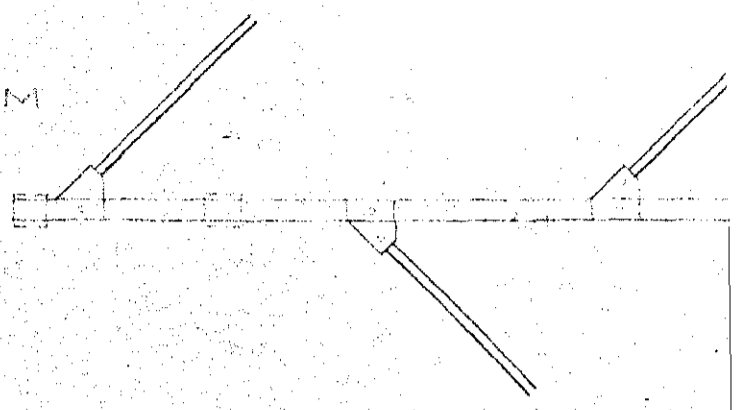

ELEMENT NO.	1	2	3	4	5
ELEMENT LG.	57	52	48	44 $\frac{15}{8}$	41
CUTSIZE	57 $\frac{3}{8}$	52 $\frac{3}{8}$	48 $\frac{3}{8}$	44 $\frac{25}{32}$	41 $\frac{3}{8}$
NOTE:	3/8 BUTT				

DEFENDANT'S
 EXHIBIT
 B39 *ed*
PHOTODUPLICATION SERVICE

1 2 3 4 5 6 7

A
B
C
D
E
F
G
H
J
K
L
M



TOP BOOM

BOTTOM BOOM

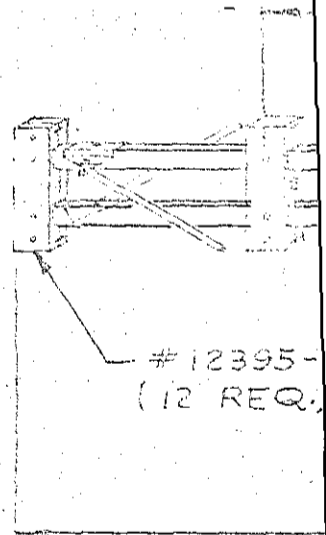
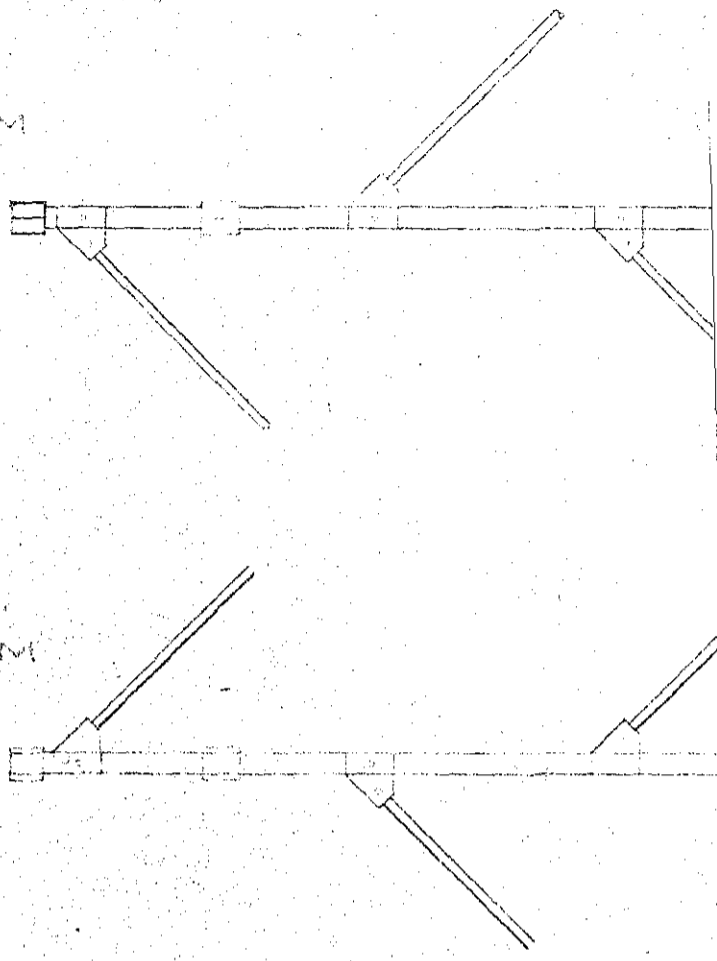

12395-
(12 REQ.)

ELEMENT NO.	1	2	3	4	5	
ELEMENT LG.	57	52	48	44	41	3
CUTSIZE	57 $\frac{3}{8}$	52 $\frac{3}{8}$	48 $\frac{3}{8}$	44 $\frac{3}{8}$	41 $\frac{3}{8}$	3
NOTE:						$\frac{3}{8}$ BUTTS

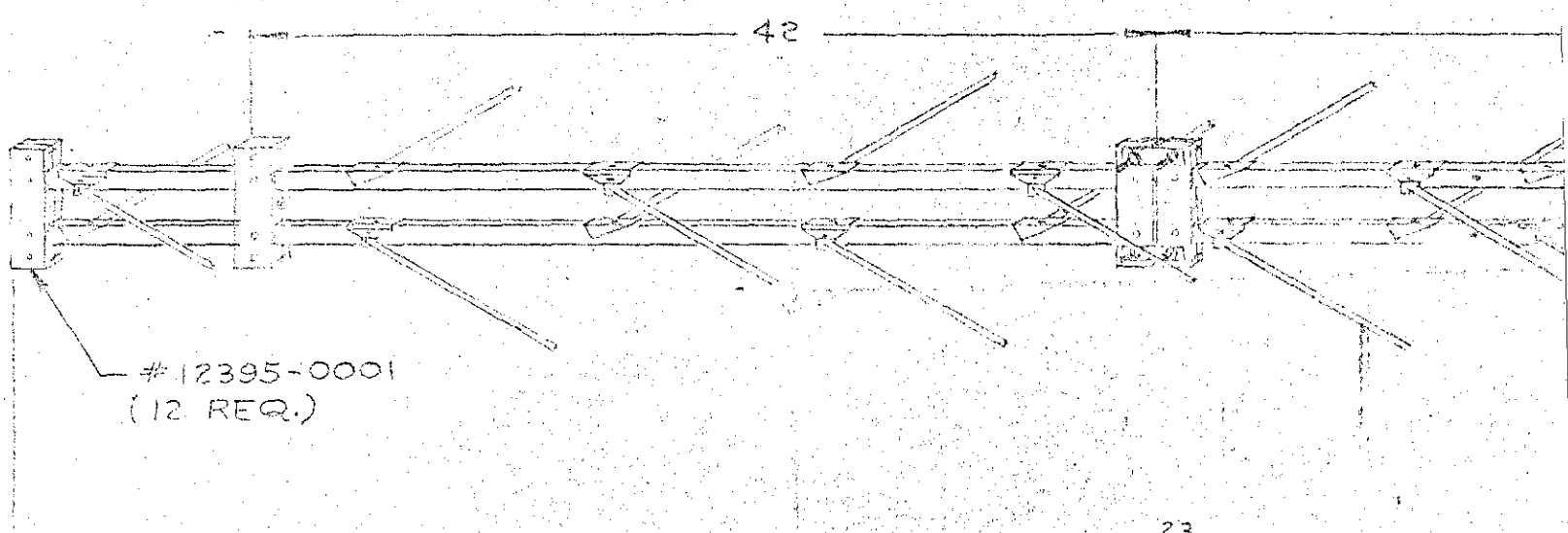
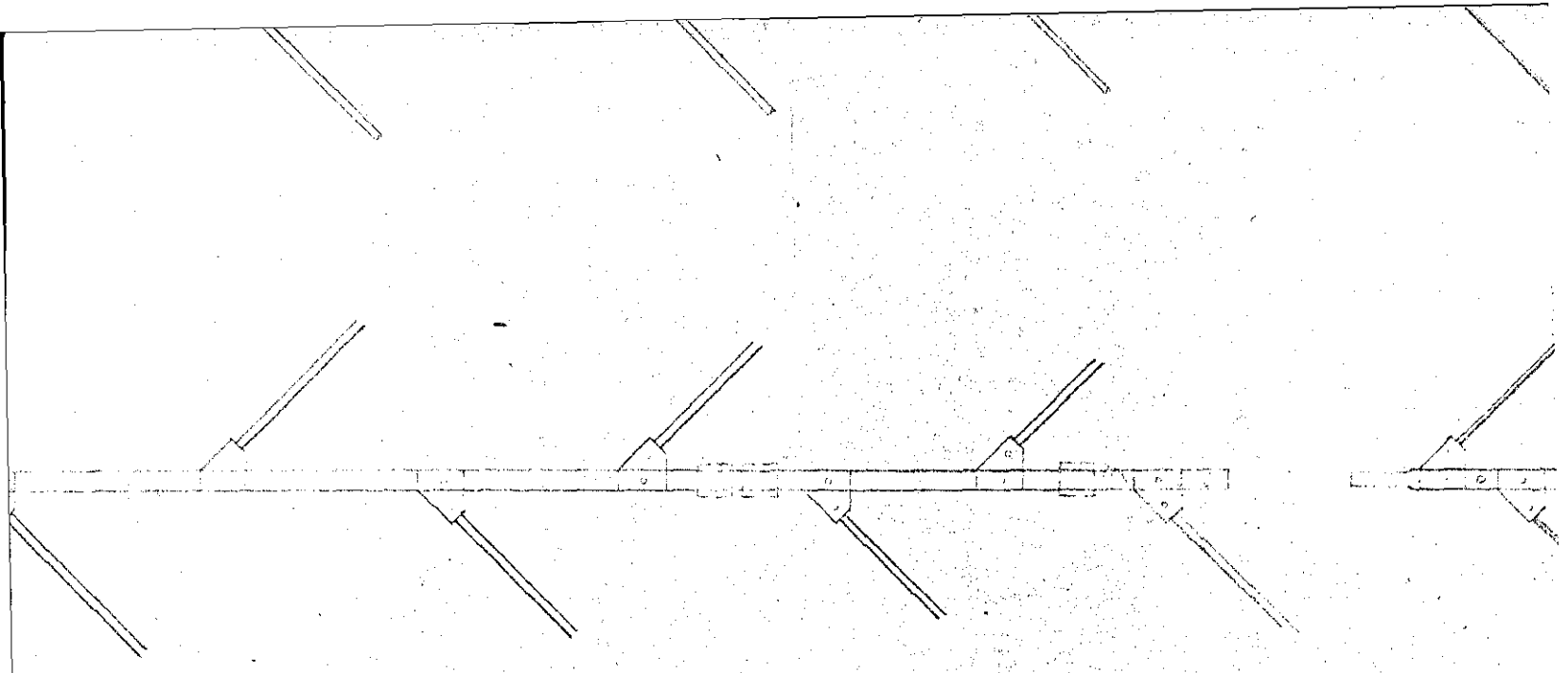

12395-0001
(12 REQ.)

95 $\frac{23}{32}$

4	5	6	7	8	9	10	11	12	13	14
44 $\frac{11}{16}$	41	38	34 $\frac{7}{8}$	31 $\frac{1}{8}$	31	29 $\frac{5}{8}$	28 $\frac{13}{32}$	27 $\frac{7}{32}$	26	25
44 $\frac{11}{16}$	41 $\frac{3}{8}$	38 $\frac{3}{8}$	35 $\frac{1}{4}$	31 $\frac{1}{2}$	31 $\frac{1}{4}$	29 $\frac{7}{8}$	28 $\frac{21}{32}$	27 $\frac{15}{32}$	26 $\frac{1}{2}$	25 $\frac{1}{4}$

$\frac{3}{8}$ BUTT SEAM

.155 DIA. WIRE

NOTE: B
CROSSBAR

ITEM NO.	NO. REQ'D	PART NO.
SCALE: APPROX. $\frac{1}{3}$:1		TOLERANCES UNLESS OTHERWISE SPECIFIED
NO. REQ'D PER ASSEMBLY:		FRACTIONAL $\pm 1/64$
MATERIAL:		DECIMAL $\pm .005$
HEAT TREAT:		ANGULAR $\pm 1/2^\circ$
FINISH:		

7

8

9

10

11

12

13

14

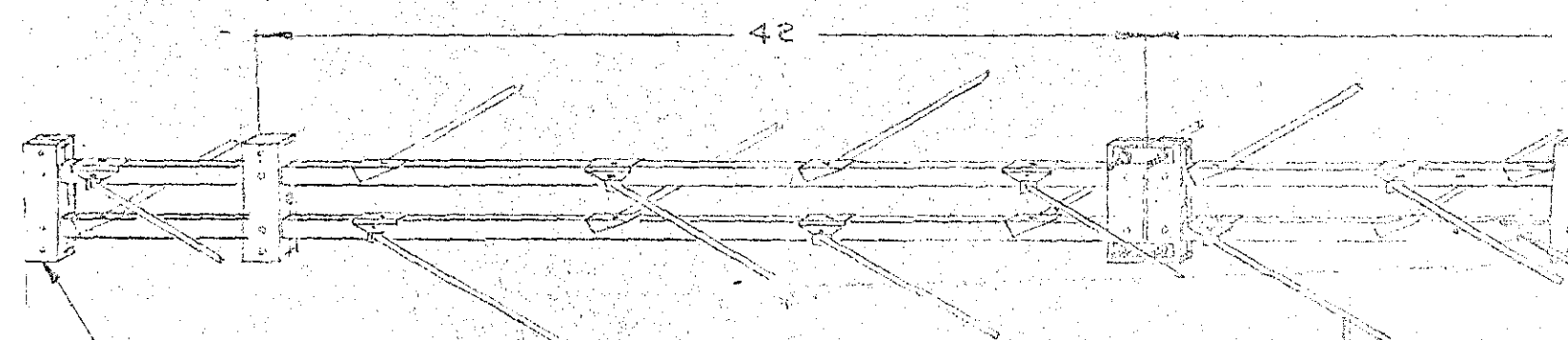
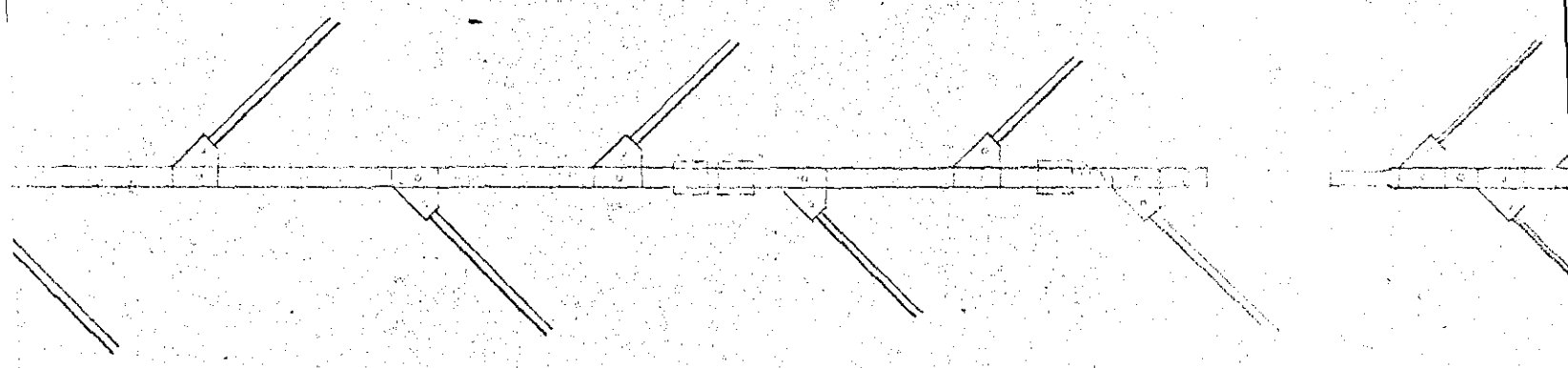
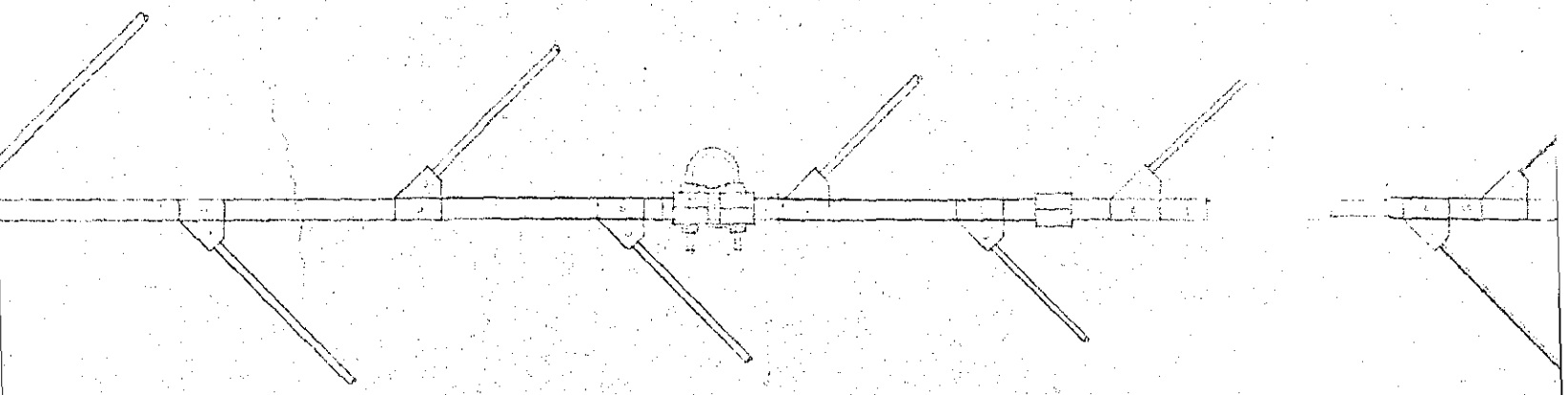

#12395-0001
(12 REQ.)

95 $\frac{23}{32}$

4	5	6	7	8	9	10	11	12	13	14
$4\frac{13}{32}$	41	38	$34\frac{7}{8}$	$31\frac{1}{8}$	31	$29\frac{5}{8}$	$28\frac{13}{32}$	$27\frac{7}{32}$	26	28
$4\frac{25}{32}$	$41\frac{3}{8}$	$38\frac{3}{8}$	$35\frac{1}{4}$	$31\frac{1}{2}$	$31\frac{1}{2}$	$29\frac{7}{8}$	$28\frac{31}{32}$	$27\frac{15}{32}$	$26\frac{1}{2}$	$25\frac{1}{2}$
$\frac{3}{8}$ BUTT SEAM								.55 DIA. WIRE		

NOTE: CO.
CROSSARM

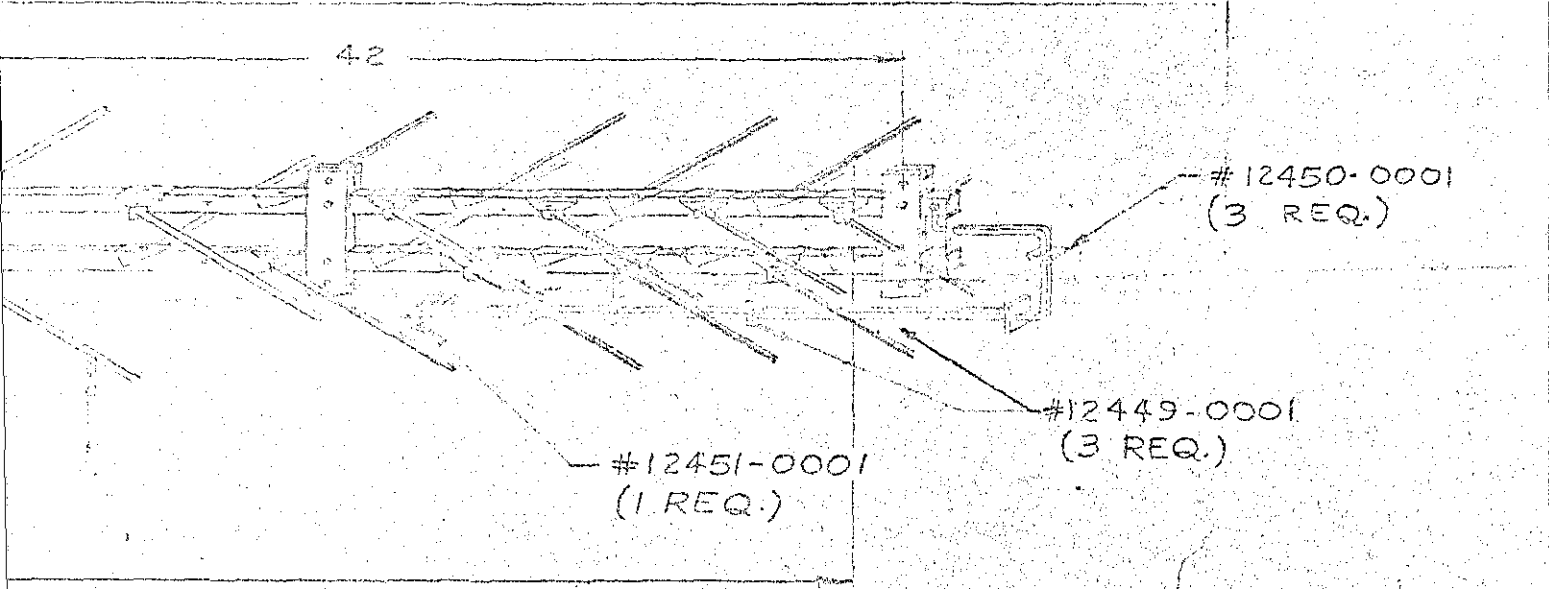
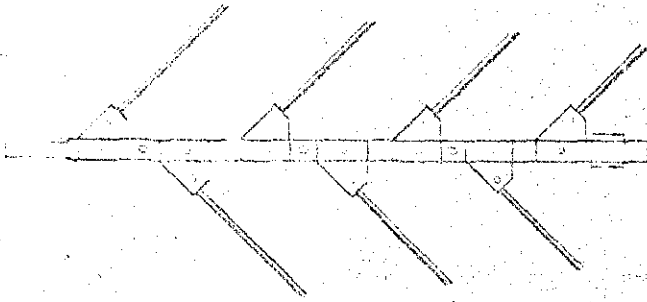

13	14	15
26	28	24
26 1/2	25 1/2	24 1/2
A. WIRE		

NOTE: BOOM BRACE PT # 11084-0901 (CMT-SIZE 5.1)

CROSSARM LENGTH - 98 31/32

PART NO.	DESCRIPTION	MATERIAL	SPECIFICATION	NOTE
	Element Twin Boom LPVVU-15		DATE OF PRINTING APR 22 1964	
	DRAWN <i>Anderson</i>	CHECKED	ENG. APP.	PROD. APP.
	JFD ELECTRONICS CORP. BROOKLYN 19, N. Y.			DRAWING NO. 52720

REV.	DESCRIPTION	DATE	APP.
A	BOOM BRACE 51' OUTSIDE W/RS 5/16"	1-1961	
B	CROSSARM CHANGED TO ONE PIECE	9-1-64	

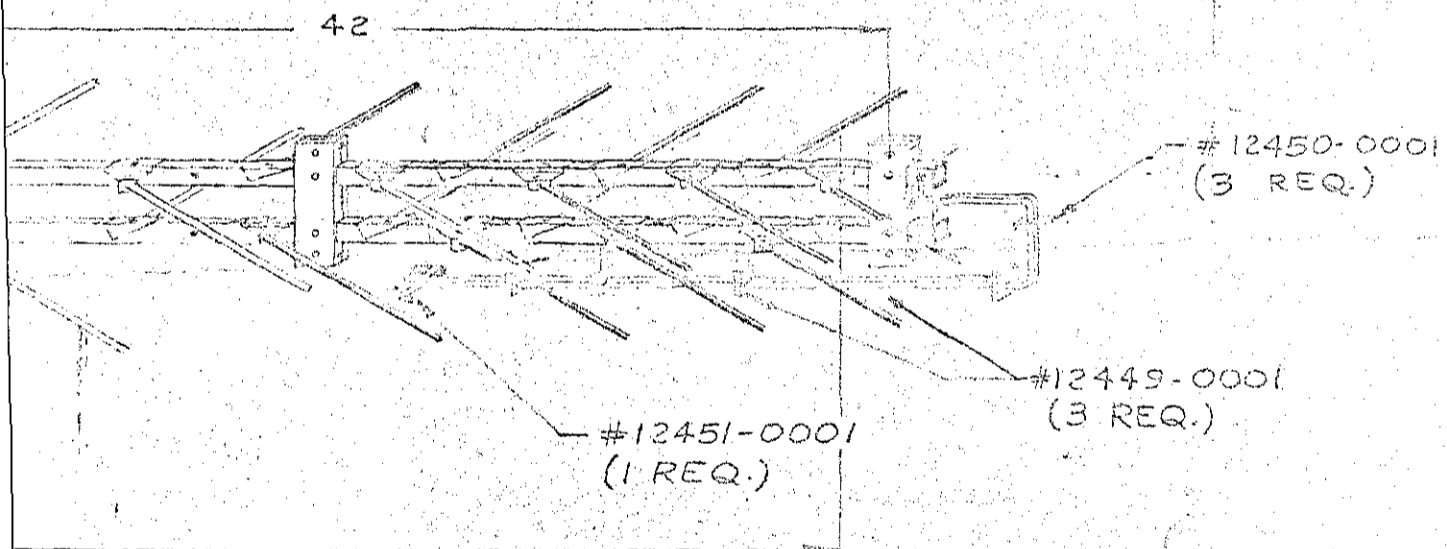
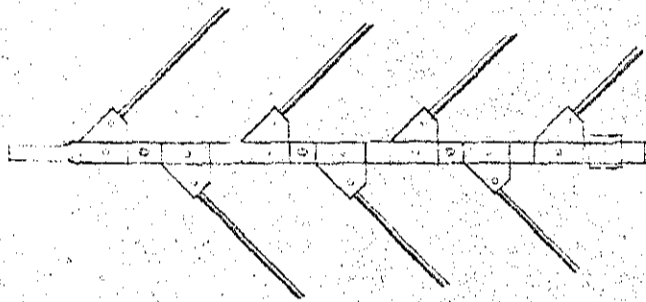
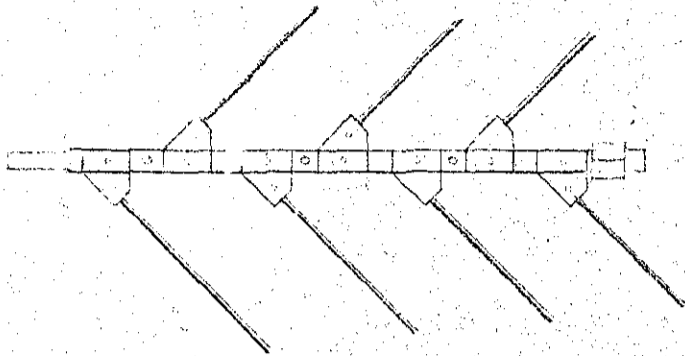

13	14	15
25	28	34
25 1/4	25 1/2	24 1/4
A. WIRE		

NOTE: BOOM BRACE PT # 11084-0001 (OUTSIDE 51)

CROSSARM LENGTH - 98 31/32

C
U
M
T
C
E
L
K
F
N
U
U

BOTTOM BOOM

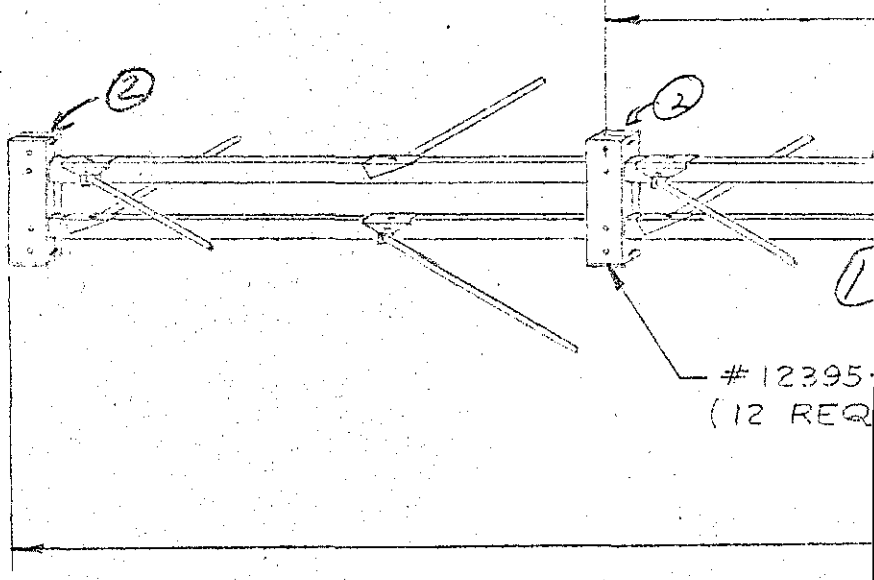
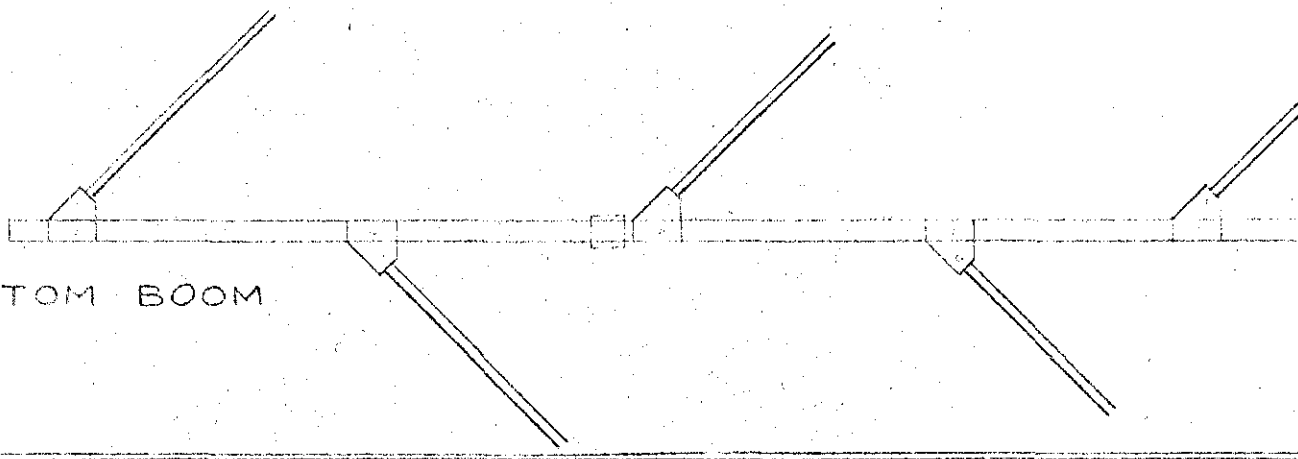

ELEMENT NO.	1	2	3	4	5
ELEMENT LG.	57	53	49 $\frac{13}{64}$	45 $\frac{39}{64}$	42 $\frac{13}{32}$
CUTSIZE	57 $\frac{3}{8}$	53 $\frac{3}{8}$	49 $\frac{5}{8}$	46	42 $\frac{13}{16}$
NOTE:	$\frac{3}{8}$ BUTT				

DEFENDANT'S
 EXHIBIT
 115210 Col
PERCAB - Bayonne, N.J.

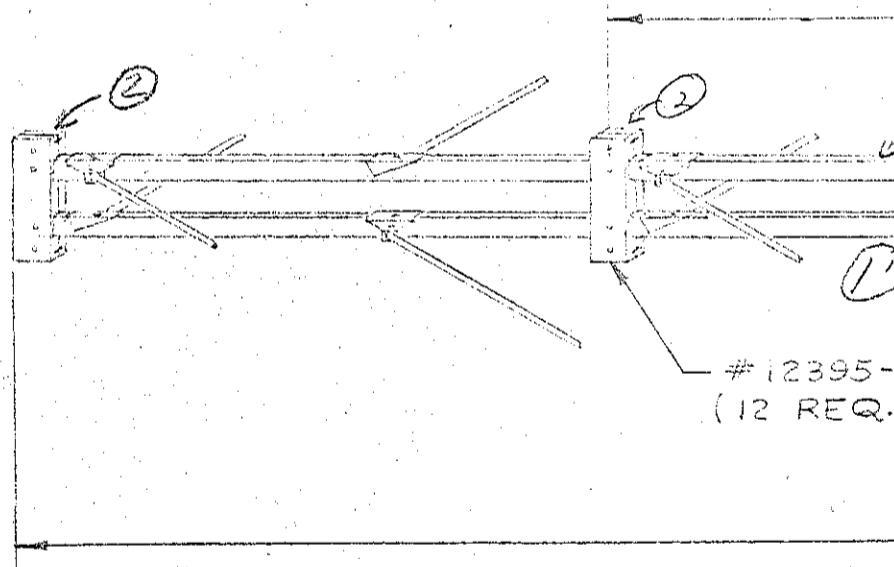
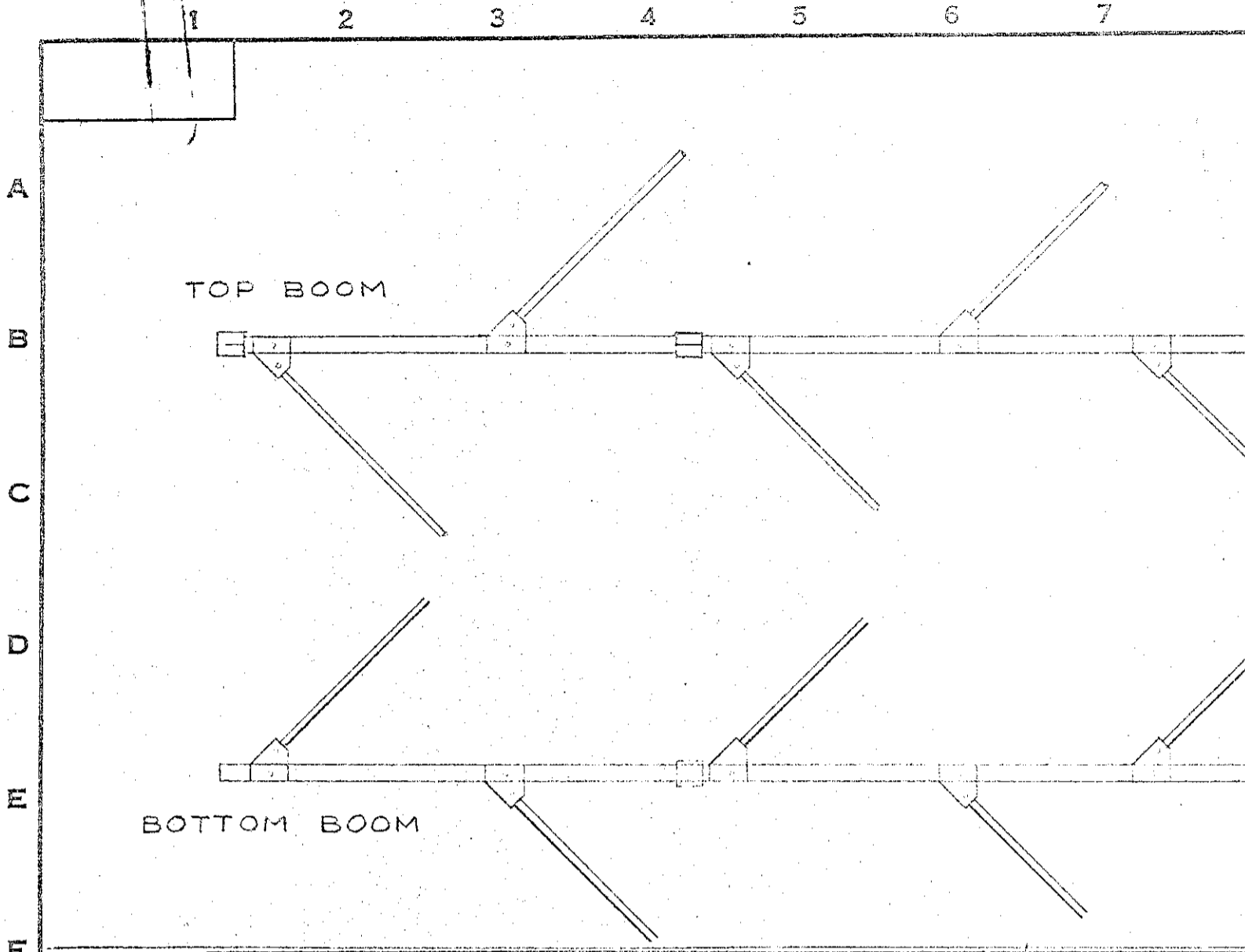

ELEMENT NO.	1	2	3	4	5
ELEMENT LG.	57	53	49 $\frac{13}{64}$	45 $\frac{39}{64}$	42 $\frac{13}{32}$
CUTSIZE	57 $\frac{3}{8}$	53 $\frac{3}{8}$	49 $\frac{5}{8}$	46	42 $\frac{13}{16}$
NOTE:	$\frac{3}{8}$ BUTT				

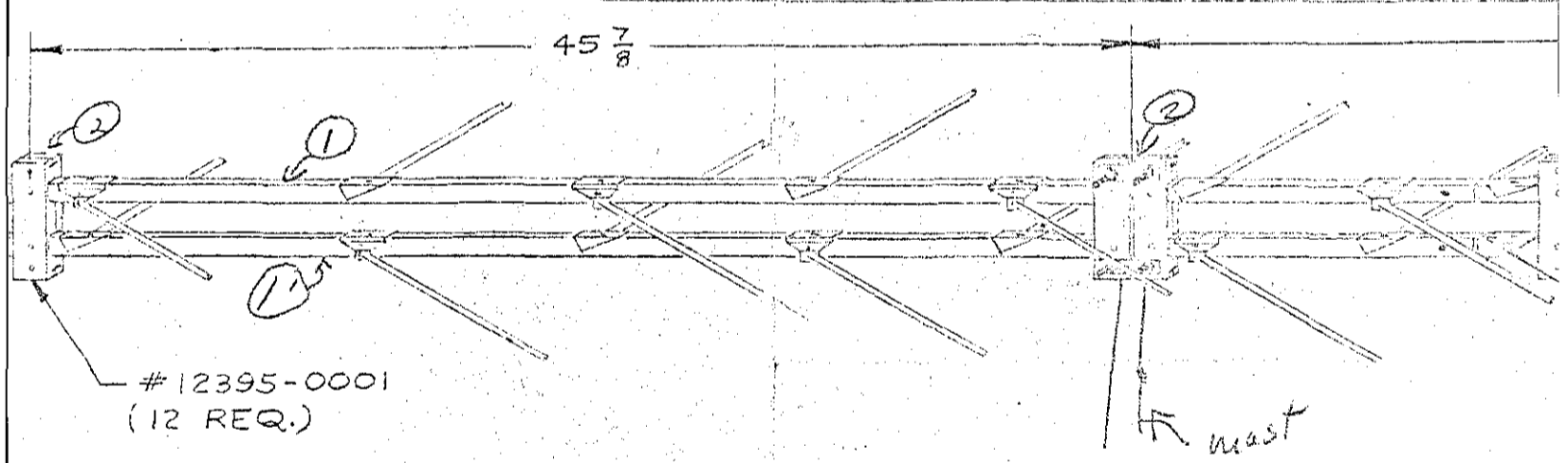
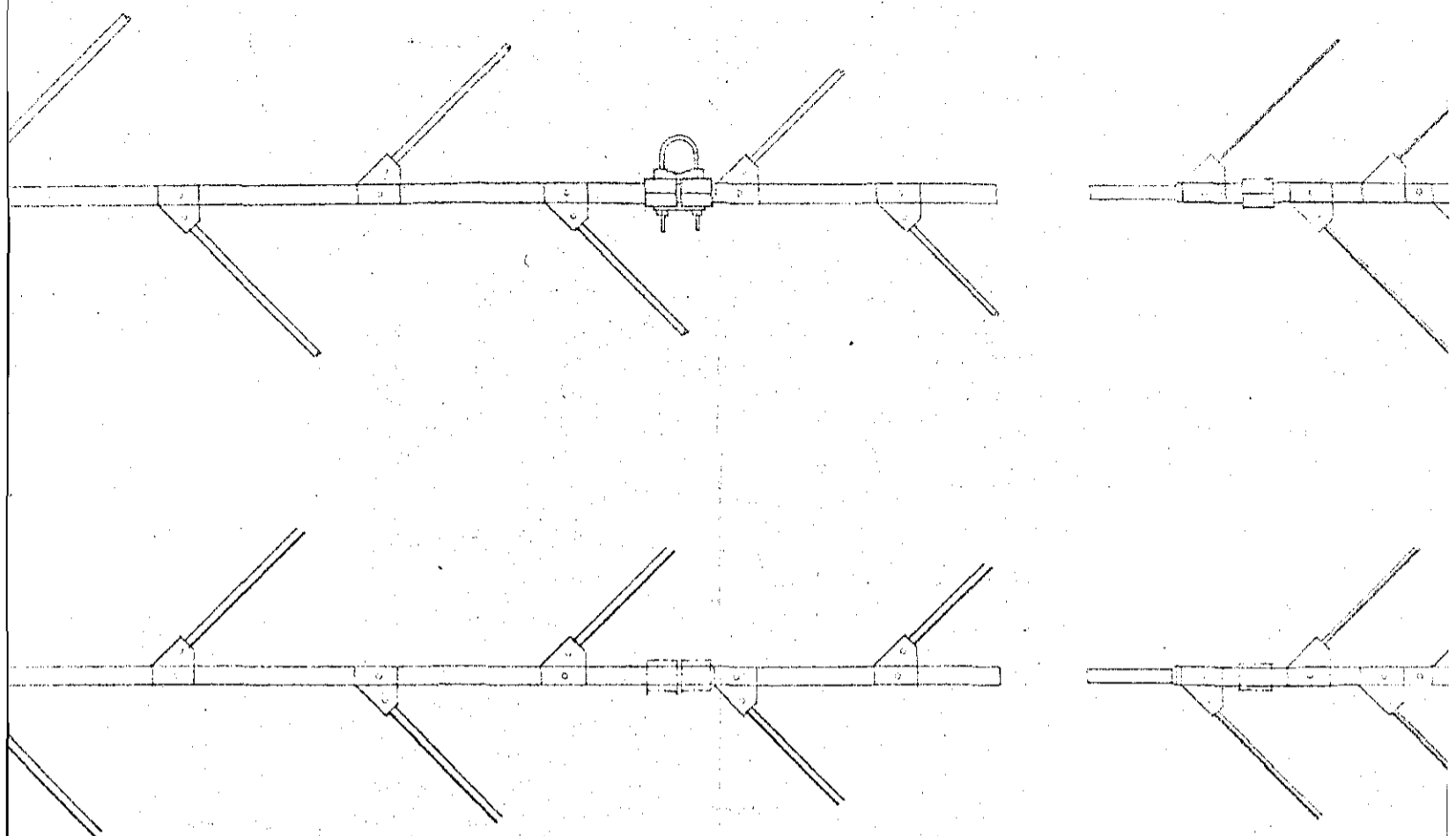

114 $\frac{25}{32}$

4	5	6	7	8	9	10	11	12	13	14
45 $\frac{39}{64}$	42 $\frac{13}{32}$	39 $\frac{13}{32}$	36 $\frac{39}{64}$	34	31 $\frac{3}{32}$	30 $\frac{29}{32}$	30 $\frac{13}{64}$	29 $\frac{13}{32}$	28 $\frac{45}{64}$	28 2
46	42 $\frac{13}{16}$	39 $\frac{13}{16}$	37	34 $\frac{3}{8}$	31 $\frac{15}{32}$	31 $\frac{5}{32}$	30 $\frac{15}{32}$	29 $\frac{21}{32}$	29 $\frac{1}{8}$	28 $\frac{1}{4}$ 2
$\frac{3}{8}$ BUTT SEAM						.155 DIA.				

NOTE: B
CROSSARM

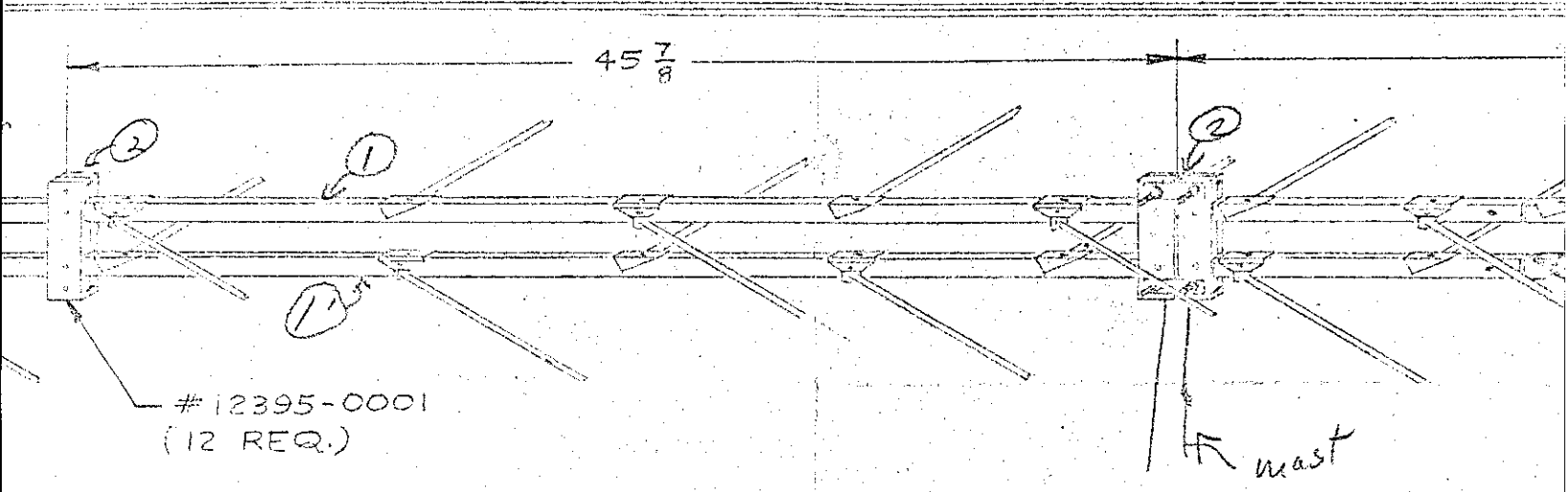
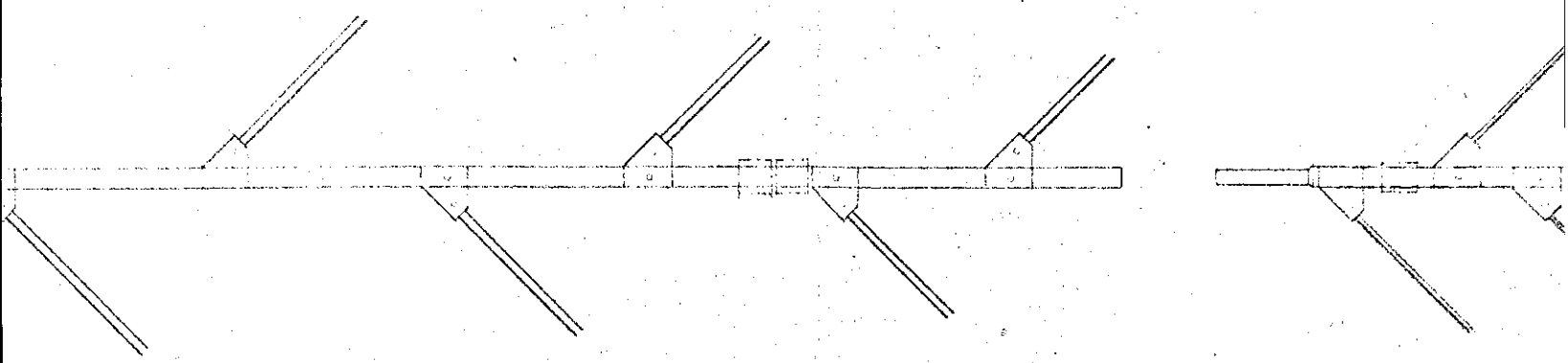

114 $\frac{25}{32}$

	4	5	6	7	8	9	10	11	12	13	14	
45 $\frac{29}{64}$	42 $\frac{13}{32}$	39 $\frac{13}{32}$	36 $\frac{39}{64}$	34	31 $\frac{3}{32}$	30 $\frac{29}{32}$	30 $\frac{13}{64}$	29 $\frac{13}{32}$	28 $\frac{45}{64}$	28		
46	42 $\frac{13}{16}$	39 $\frac{13}{16}$	37	34 $\frac{3}{8}$	31 $\frac{15}{32}$	31 $\frac{5}{32}$	30 $\frac{15}{32}$	29 $\frac{21}{32}$	29 $\frac{1}{8}$	28 $\frac{1}{4}$		
3/8 BUTT SEAM.												.155 DIA

NOTE:
CROSSAR

ITEM NO.	NO. REQ'D	PART NO.
SCALE: APPROX. $\frac{1}{8}$:1		TOLERANCES UNL.
NO. REQ'D PER ASSEMBLY:	∞	OTHERWISE SPECI.
MATERIAL:	∞	FRACTIONAL $\pm 1.$
HEAT TREAT:	∞	DECIMAL $\pm .0$
FINISH:		ANGULAR $\pm 1.$

14

15

16

17

REV.

DESCRIPTION

DATE

APP.

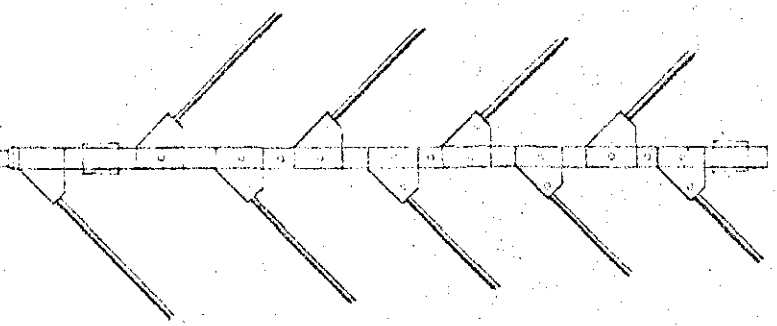
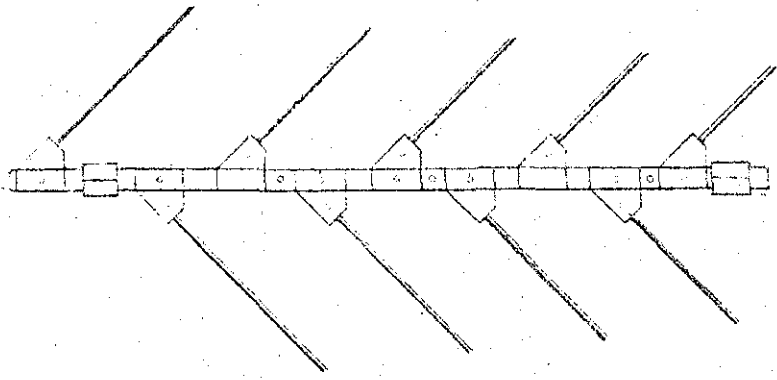
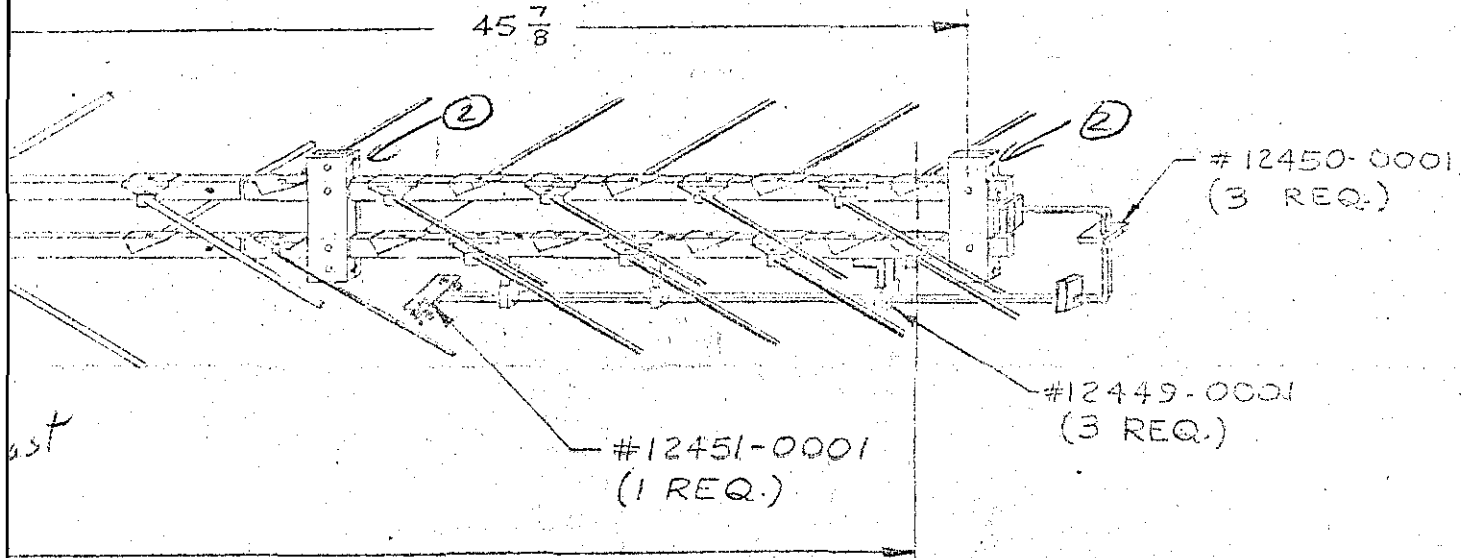
45 $\frac{7}{8}$ #12450-0001
(3 REQ.)#12449-0001
(3 REQ.)#12451-0001
(1 REQ.)

13	14	15	16	17	18
28 $\frac{45}{64}$	28	27 $\frac{5}{16}$	26 $\frac{45}{64}$	26	25 $\frac{1}{4}$
29 $\frac{1}{8}$	28 $\frac{1}{4}$	27 $\frac{9}{16}$	27 $\frac{1}{8}$	26 $\frac{1}{4}$	25 $\frac{1}{2}$
.155 DIA. WIRE					

NOTE: BOOM BRACE PT #11084-14 (OUT-SIZE 54 $\frac{1}{2}$)
 CROSSARM LENGTH - 118 $\frac{1}{32}$

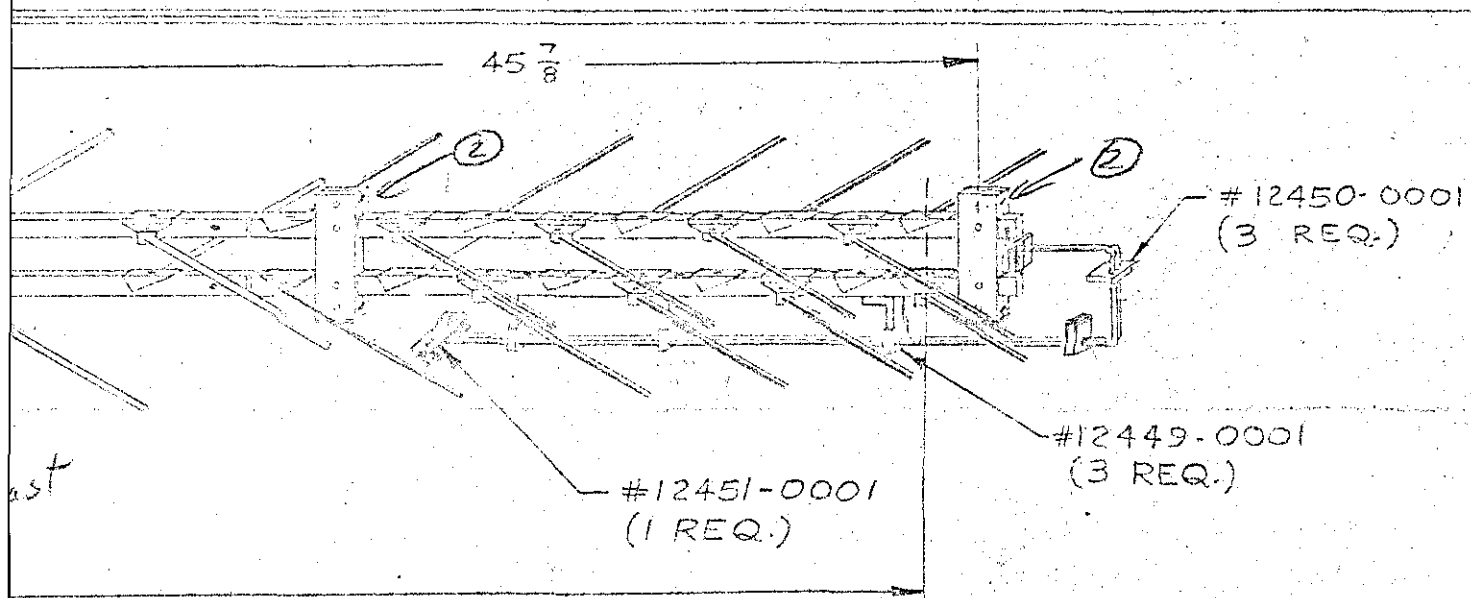
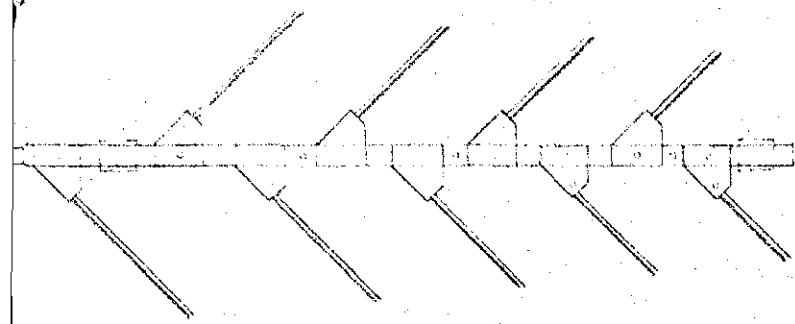

13	14	15	16	17	18
23 $\frac{45}{64}$	28	27 $\frac{5}{16}$	26 $\frac{45}{64}$	26	25 $\frac{1}{4}$
29 $\frac{1}{8}$	28 $\frac{1}{4}$	27 $\frac{9}{16}$	27 $\frac{1}{8}$	26 $\frac{1}{4}$	25 $\frac{1}{2}$
.155 DIA. WIRE					

NOTE: BOOM BRACE PT #11084-14 (OUT-SIZE 54 $\frac{1}{2}$)
 CROSSARM LENGTH - 118 $\frac{1}{32}$

PART NO.	DESCRIPTION	MATERIAL	SPECIFICATION	NOTE
	18 Element Twin Boom LPVVU-18		DATE OF PRINTING	
			APR 22 1954	
			NEXT ASSEMBLY	
		DRAWN	CHECKED	ENG. APP.
		<i>Andersen</i>		
		52-14-13		
	JFD ELECTRONICS CORP.			
	BROOKLYN 19, N.Y.			
				DRAWING NO.
				52730

XB4/12
1. Antenna models LPV-4, LPV-6, LPV-8 and LPV-11 were first produced on the same day, that is, December 27, 1962, and we must assume that they were first sold shortly thereafter. It is possible that this first production was made to fulfill orders already taken. In any event, we can assume that these model antennas were first shipped shortly after December 27, 1962. We do not know which of these four antennas were the first to be made and sold by JFD under its license, since production on all four was initiated on the same day.

3. With respect to your request for the first sale of each model of antenna sold by JFD under its license, the following listing is pertinent (the dates given are first production dates and it may be assumed that the first shipment and actual sale were made shortly after the date of production given):

LPV-4	}	See Paragraph above
LPV-6		
LPV-8		
LPV-11		
LPV-14		February 4, 1963
LPV-17		March 19, 1963
LPV-U 5		December 26, 1963
LPV-U 9		December 27, 1963
LPV-U 15		December 31, 1963
LPV-U 21		January 17, 1964
LPV-VU 6		January 28, 1965
LPV-VU 9		November 7, 1964
LPV-VU 12		October 27, 1964
LPV-VU 15		October 6, 1964
LPV-VU 18		September 30, 1964
LPV-ZU 10		March 25, 1964
LPV-ZU 20		March 26, 1964
LPL-FM 4		July 13, 1964
LPL-FM 6		April 13, 1964
LPL-FM 8		June 5, 1964
LPL-FM 10		June 5, 1964

We want to advise that model numbers LPV-VU 12, LPV-VU 15, and LPV-VU 18 had versions thereof manufactured specifically for Sears, Roebuck & Company, and same were shipped in Sears cartons, production respectively beginning February 11, 1964, January 8, 1964, December 31, 1963. In these different versions, specifically for Sears, the rods were solid rather than hollow otherwise they were the same design. We do not know what, if any, patent notice was placed on the Sears cartons.

We also want to advise that Model LPV-VU 5 was first produced March 4, 1966.

70 MILLION FAIR VISITORS WILL SEE AND HEAR ABOUT
 PATENTED
 THE LOG-PERIODIC LPV - THE EXCLUSIVE CHOICE OF TV

4
 B15

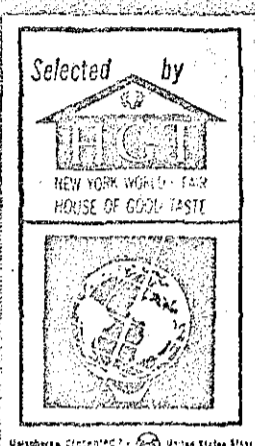
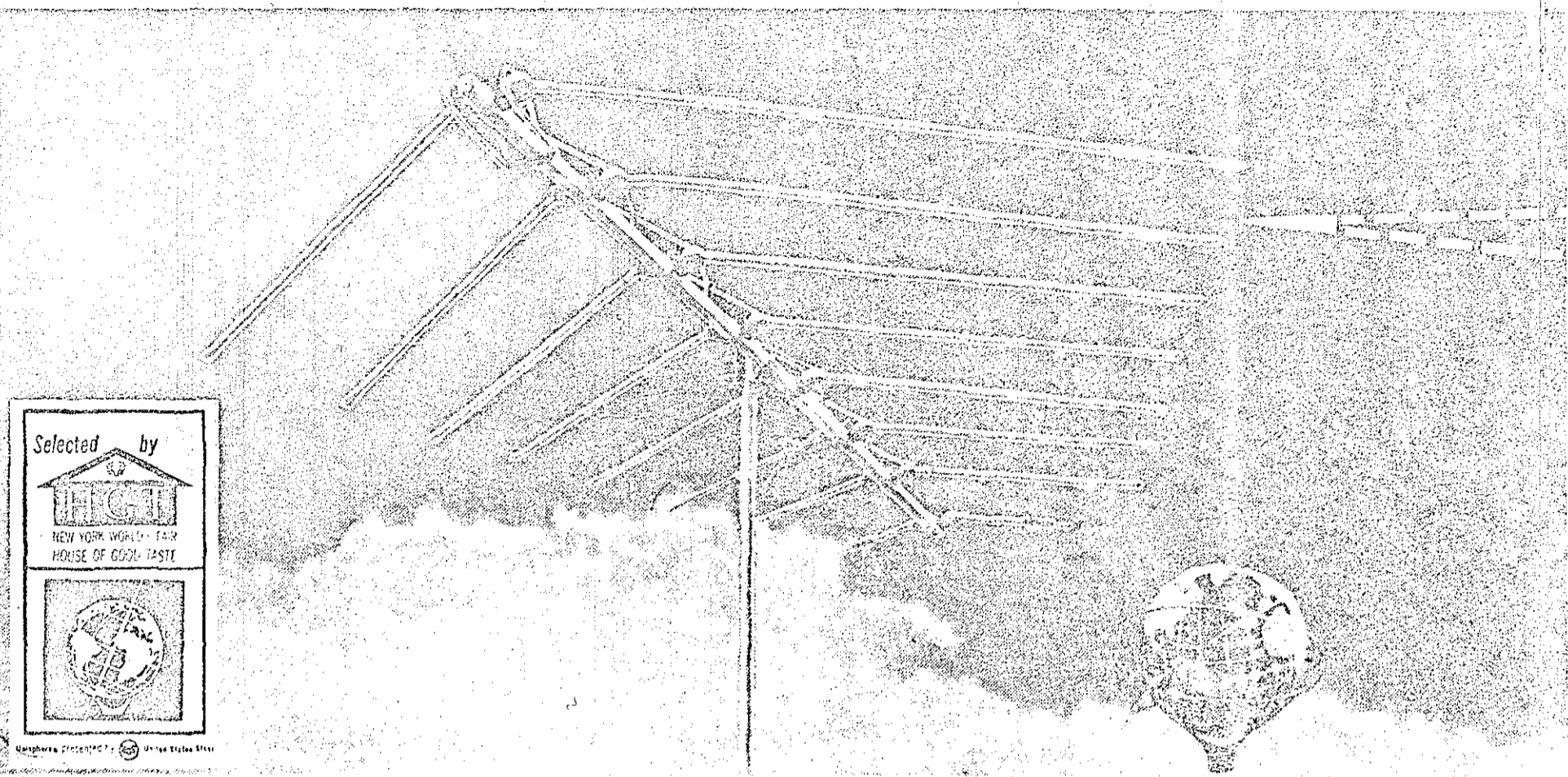

Now — the antenna designed to meet satellite telemetry needs has been adapted by JFD to help you and your customers get far better reception in COLOR, black/white, and FM!

Achievements of University of Illinois Laboratories Are Now Translated Into Finer Pictures, Clearer FM Stereo!

This means far fewer service calls . . . far more customer satisfaction with what you sell . . . far greater profits at the end of year. And, the World's Fair will demonstrate this antenna to 70 million Fair-goers in 1964 and 1965!

Cash in starting now on the profit opportunity of the year!

The space-age Log Periodic principle of the Antenna Research Laboratories of the University of Illinois has been acclaimed as the most significant antenna discovery since the invention of the Yagi. This patented Log Periodic concept—adapted by the JFD Research and Development Laboratories in Champaign, Illinois—is now available in a unique new line of LPV antennas for VHF, UHF and FM stereo.

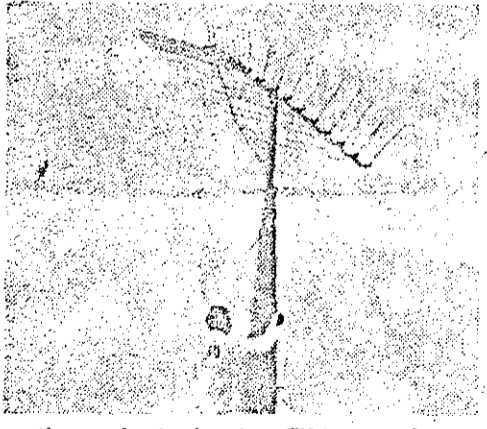

The secret is in its frequency-independent design. All elements are designed according to the patented log periodic formula. They all work like a powerful tuned multi-element Yagi—not on just one or a few channels as do other antennas—but on all channels across the band.

The result is far superior gain, directivity, front-to-back ratio, and VSWR that lights up

the weakest, ghostiest TV image with sparkling detail and contrast—for superb color, as well as black and white pictures—plus fidelity FM stereo!

A NEW PERFORMANCE-PROVED LOG PERIODIC LPV FOR UHF, VHF-UHF, FM STEREO)... EVERY PROBLEM (GHOSTS EVERY LOCATION (LOCAL, SUBURBAN, & FRINGE) OF TV MARKETS FOR ALL DEALERS!

Gold Alodized VHF Log Periodic LPV TV/FM ANTENNAS for Channels 2 to 13 plus FM Stereo

Model LPV11 illustrated for fringe areas

This LPV TV antenna series, the first ever to utilize the revolutionary Log Periodic concept, opened a new era in TV/FM performance.

Gold Alodized VHF Log Periodic LPV TV ANTENNAS for Channels 2 to 13 plus FM Stereo (available in 6 area engineered models)

Model LPV-U9 illustrated for local & suburban



Here's an all new UHF series employing Log Periodic design to provide the high-gain, ghost-free signal needed especially by UHF sets for sharp, steady pictures on channels 14 to 83 and to cash in on the great new UHF market.

Gold Alodized UHF Log Periodic LPV TV ANTENNAS for channels 14 to 83 plus VHF channels 7 to 13 (available in 4 area engineered models)

Model LPV-2010 illustrated

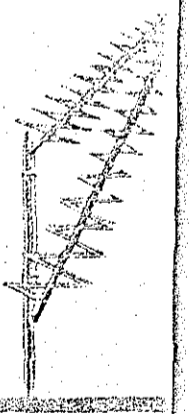

Model LPV-VU15 for suburban-fringe areas



Tomorrow's antenna today. The most advanced application of the Log-Periodic formula—receives all FCC authorized television channels on VHF (2 to 13), on UHF (14 to 83) plus all FM and FM Stereo Frequencies. This is the first single all-channel antenna using a single down-lead to achieve this performance

break-through! (Includes VHF-UHF Splitter for separate lead-ins to VHF and UHF set terminals.)

Gold-Alodized VHF-UHF Log-Periodic LPV ANTENNAS for channels 2 to 83 plus FM Stereo (soon available in 4 models)

THERE IS ONLY ONE GENUINE PATENTED LOG-PERIODIC V-ANTENNA

JFD LPV

Only JFD is licensed exclusively by the University of Illinois Foundation to make the patented Log-Periodic LPV and all other Log-Periodic type TV and FM antennas. No other so-called Log-Periodic antenna can work like the JFD Log-Periodic LPV because only JFD uses the original patented Log-Periodic design formula of the Antenna Research Laboratories of the University of Illinois. Rely on the JFD LPV and see why at the moment of truth, the picture is the proof—that the LPV works best! Now in stock at your JFD distributor.

LICENSED UNDER ONE OR MORE OF U.S. PATENTS 2,958,081; 2,985,879; 3,011,168; 3,108,280 AND ADDITIONAL PATENTS PENDING IN U. S. A. AND CANADA. PRODUCED BY JFD ELECTRONICS CORPORATION UNDER EXCLUSIVE LICENSE FROM THE UNIVERSITY OF ILLINOIS FOUNDATION.

Copyright JFD Electronics Corp. 1964

THE KNOW-HOW OF THE WORLD'S NEWEST AND FINEST ANTENNA LABORATORIES IS BUILT INTO EACH JFD LPV ANTENNA YOU SELL!



The Log-Periodic concept is the result of five years of intensive electronic studies at the Antenna Research Laboratories of the University of Illinois and JFD. Located in Champaign, Illinois (home of the University of Illinois), the vast new JFD research center is the largest and most complete of its kind.

Professor Paul Mayes of the Antenna Research Laboratories of the University of Illinois, originator of the log-periodic V-dipole antenna concept.

OUT THIS REMARKABLE NEW JFD TV/FM ANTENNA!

B15-
all

THE NEW YORK WORLD'S FAIR HOUSE OF GOOD TASTE!

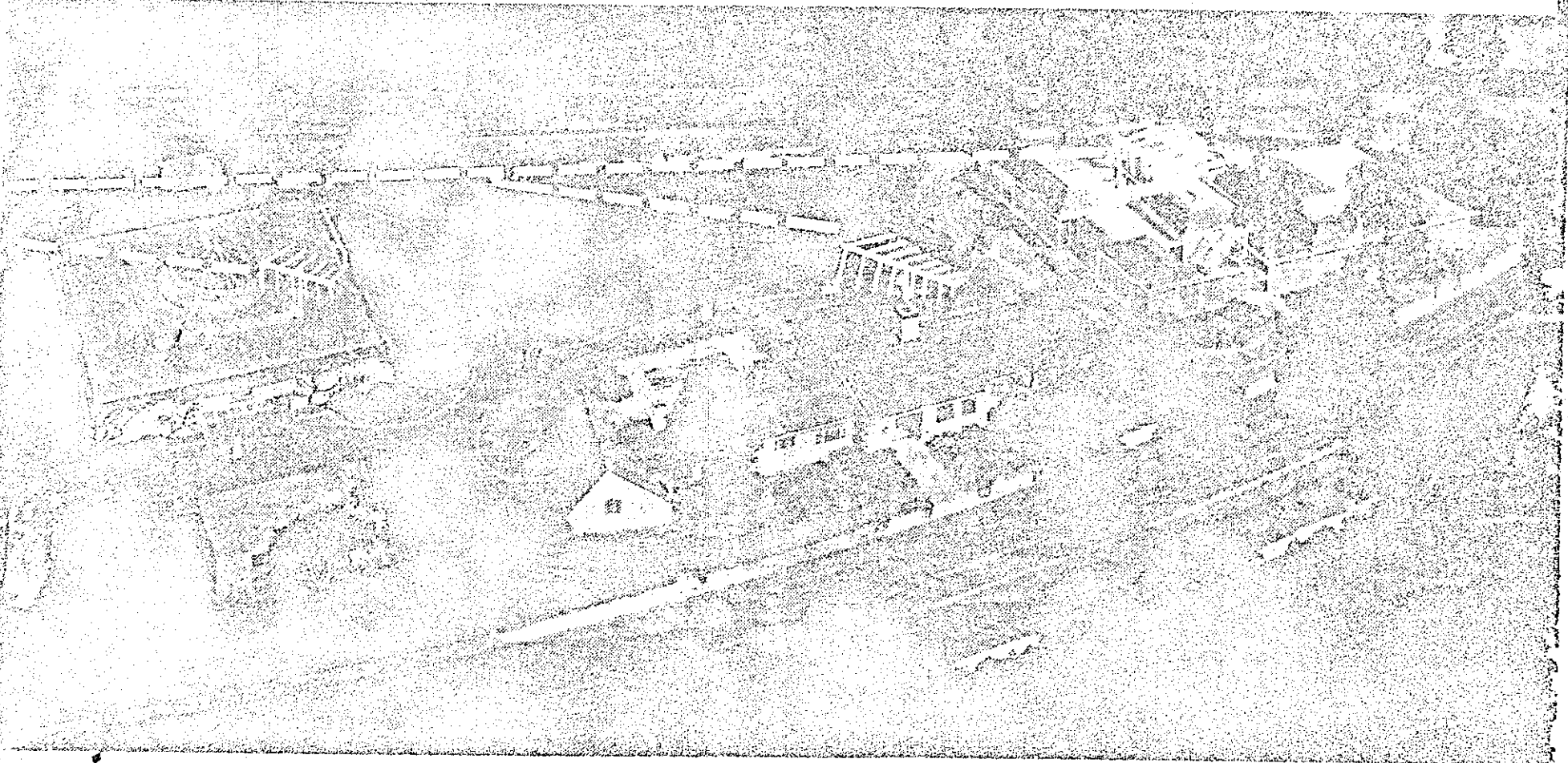

EVERY BAND (VHF,
OR INTERFERENCE)...
PROFITABLE NEW

You Win All Ways When You Feature The JFD LOG PERIODIC LPV!

1. Exclusive Log Periodic demonstration in one of the Fair's chief exhibits--The House of Good Taste!
2. Free dealer Holiday at the fabulous New York World's Fair!
3. Tremendous sales impact of World's Fair tie-in publicity, promotion and advertising!

In 1964 and 1965, JFD puts the prestige and drawing power of the biggest attraction of all time behind every JFD Log Periodic LPV TV/FM antenna you sell--the New York World's Fair!

Millions at the Fair, millions more everywhere in America will see, hear and read why the House of Good Taste chose the JFD Log Periodic LPV as the only antenna to be used in its showcase of the finest in American home living.

This powerful new marketing force will be at your service... Log Periodic LPV Sales and profits for you!

PLUS!—

Every JFD VHF, UHF or VHF-UHF Log-Periodic LPV you buy between March 1, 1964 and August 31, 1965 earns you valuable JFD Fair Festival Certificates which you can:

1. Trade in for FREE World's Fair Adult Admission Tickets (worth 150 points) or...
2. Trade in for FREE 3-day, 2-night Fair week-end holiday (worth 3,000 points) or...
3. Redeem for \$1.25 cash for each 150 points, from JFD.

JFD Dealer Point Values for Log-Periodic Antennas:

Model	Points	Model	Points
LPV17	60	LPV-U15	20
LPV14	50	LPV6, LPV6PM	15
LPV11	35	LPV4, LPV:PM	10
LPV-U21	30	LPV-U9	10
LPV8, LPV8PM	25	LPV-U5	5

IT'S THE PROFIT/ENTERTAINMENT OPPORTUNITY OF THE YEAR!

—AND TO HELP YOU SELL MORE LPV LOG PERIODIC ANTENNAS, JFD OFFERS YOU A SENSATIONAL WORLD'S FAIR TIE-IN PROMOTION PROGRAM

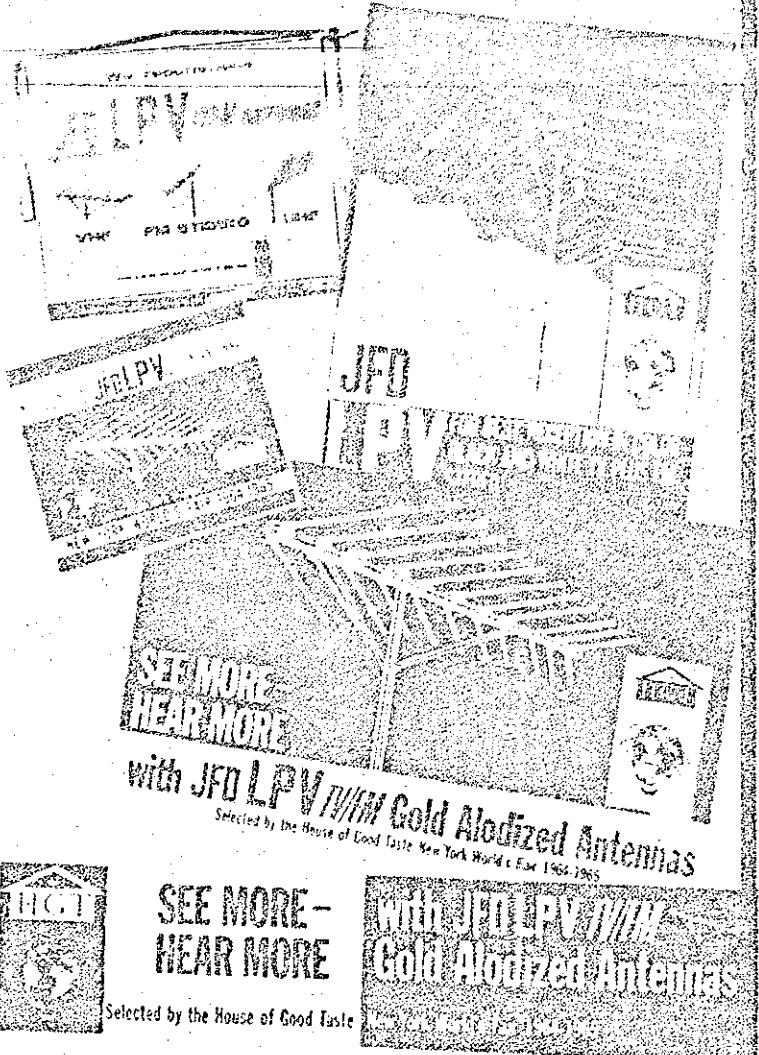

suburban areas

This exotic all-new UHF series obsoletes bulky parabolics and stacked bowtie-reflector and corner reflector antennas. Packs more long-distance pick-up sensitivity per element. Another ahead-of-the-industry antenna advance that puts you in command of new UHF antenna business in your town.

Gold Alodized UHF Log Periodic Planar Helical ZAGI TV ANTENNAS for channels 14 to 83

(available in 2 area-engineered models)

Model LPT100 illustrated

Never before an indoor antenna like this. The first ever engineered according to the patented log-periodic formula. Actually outperforms some roof-top UHF antennas. Tunes itself electronically (without switches) to desired channel. Gold Alodized INDOOR UHF Log Periodic Trapezoid TV ANTENNA for channels 14 to 83

AT THE MOMENT OF TRUTH, THE PICTURE IS THE PROOF THE JFD LOG-PERIODIC LPV WORKS BEST!

INSIST ON JFD LOG-PERIODICS WITH THE EQUIPMENT YOU SELL FOR MORE SALES AND PROFITS!

Write for complete details or see your JFD LPV distributor today!

JFD

JFD ELECTRONICS CORPORATION

15th Avenue at 62nd Street, Brooklyn, N. Y. 11219

JFD Electronics Southern Inc., Oxford, North Carolina
JFD International, 64-14 Woodside Ave., Woodside 77, N. Y.
JFD Canada, Ltd., 51 McCormack Street, Toronto, Ontario, Canada
401-144 W. Hastings Street, Vancouver 3, B.C.

LPV®

ADVERTISED IN
LOOK / Sunset

Revolution in the Air:

JFD PRESENTS

Initially Developed by the Antenna Research Laboratories of the University of Illinois*, Proved-Out in Air

IT COULD ONLY HAVE BEEN PRODUCED by such massed resources as those of a prominent university, the military, and the country's leading antenna manufacturer. BECAUSE ITS GAIN IS INDEPENDENT OF FREQUENCY, the backward-wave log-periodic LPV functions with high efficiency across the entire band. This end-fire array is comparable on any channel to a tuned Yagi cut to that channel. ON VIRTUALLY EVERY COUNT, IT OUTPERFORMS PREVIOUS WIDE-BAND ARRAYS: in gain, in directivity, in bandwidth, in front-to-back ratio. It has gains as high as 14 db. in the 17-element model. It shows flat response across both TV bands—with greater gain on the high band, where it's needed most. Result: An all-channel, all-

purpose antenna with unprecedented gain, a decisive end to snow and ghosts and the truest color reception yet—as well as vivid sharpness in black and white. The basic log-periodic LPV principle will be also adapted to all future UHF antenna needs.

MORE, FARMORE, THAN JUST A "FRINGE" SOLUTION, the log-periodic LPV gives superior reception in all multi-channel areas. It is the first true "universal" TV antenna. It will open key profit opportunities to you in the months ahead—not only because it puts better reception within the reach of virtually every TV set-owner, but because it enables you for the first time to meet all antenna needs with a single antenna line.

*PRODUCED EXCLUSIVELY BY JFD ELECTRONICS UNDER LICENSE TO THE UNIVERSITY OF ILLINOIS
U.S. PATENT NUMBERS 2,958,081—2,985,879—3,011,168 . ADDITIONAL PATENTS PENDING

LOG-PERIODIC
LPV $\frac{L(n+1)}{L_n} = \tau$
TV ANTENNA

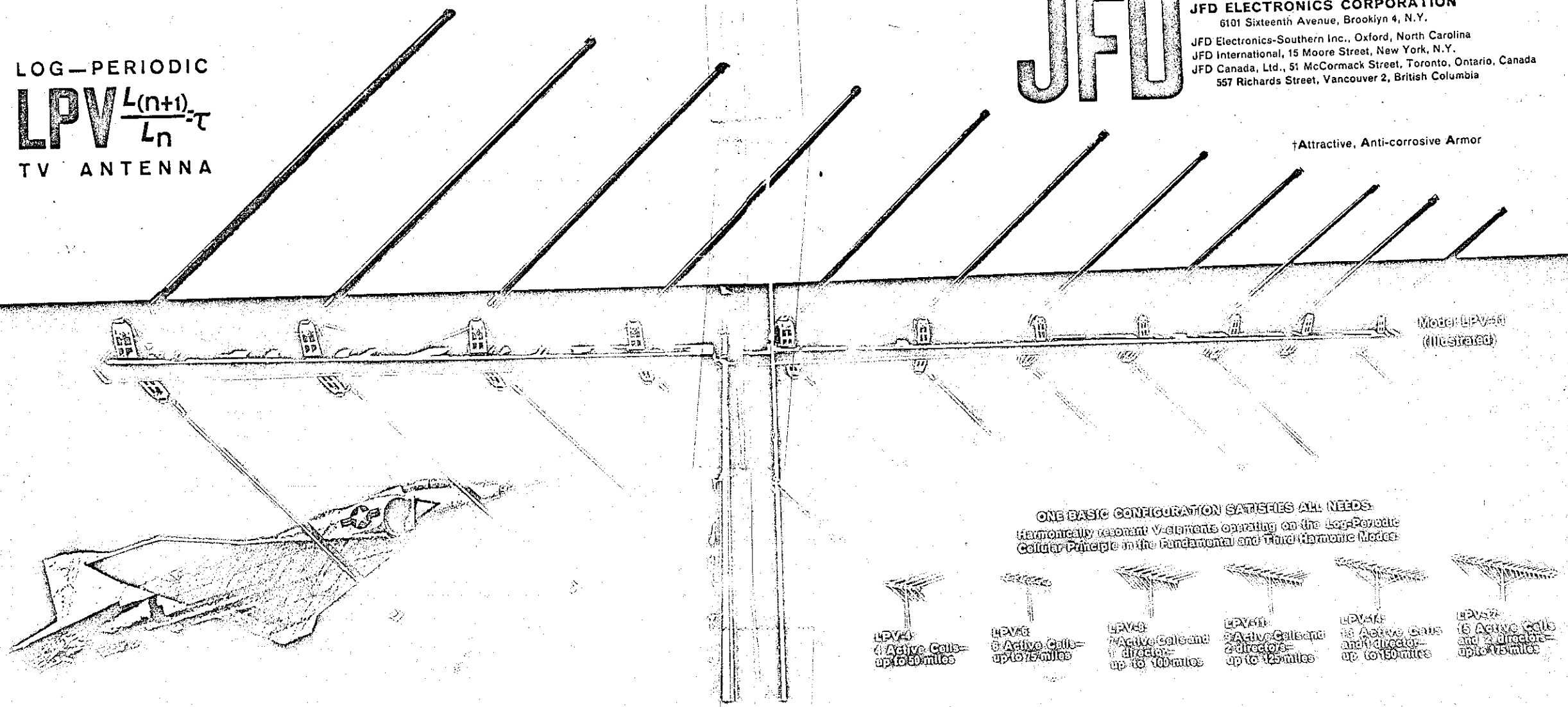

ONE BASIC CONFIGURATION SATISFIES ALL NEEDS:
Harmonically resonant V-elements operating on the Log-Periodic Cellular Principle in the Fundamental and Third Harmonic Modes

- LPV4: 4 Active Cells—up to 4 miles
- LPV6: 6 Active Cells—up to 6 miles
- LPV8: 8 Active Cells and 2 directors—up to 8 miles
- LPV10: 10 Active Cells and 2 directors—up to 10 miles
- LPV12: 12 Active Cells and 2 directors—up to 12 miles
- LPV16: 16 Active Cells and 2 directors—up to 16 miles

A-34

THE LOG-PERIODIC LPV

Force Satellite Telemetry, Adapted to TV by JFD—Ending the "Era of Compromise" in TV Antenna Design

NOT A "CATCH-ALL COMPROMISE"—the log-periodic LPV signals a halt to the endless piling-on of narrow-band elements and parasitics. It is essentially frequency-independent since it is derived from an antenna geometry that repeats the electrical properties of the basic element, or cell, periodically; the periodicity being proportional to the logarithm of the frequency. (Actually, the basic log-periodic design is capable of flat response over a frequency range as broad as 20 to 1.)

BASED ON PRINCIPLES DESIGNED TO MEET RIGOROUS AIR FORCE PERFORMANCE STANDARDS—built to uncompromising JFD specifications—of AAA Gold Bond Alodized aircraft aluminum for enduring good looks.

100% PREASSEMBLED FLIP-QUIK CONSTRUCTION—with new "tank-turret" aluminum brackets that align and double lock the elements instantly and permanently in place.

RECEIVES STEREO FM, TOO—delivers drift- and distortion-free FM stereo.

SEE THE LOG-PERIODIC LPV AT YOUR JFD DISTRIBUTOR—study the performance figures—try it—see for yourself how the LPV towers over all other broad-line antennas.

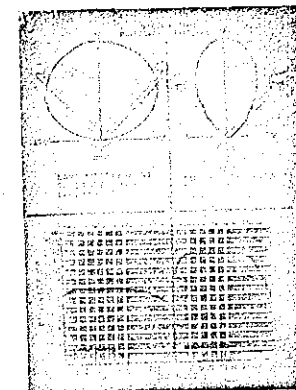

JFD

THE BRAND THAT PUTS YOU IN COMMAND OF THE MARKET
JFD ELECTRONICS CORPORATION
6101 Sixteenth Avenue, Brooklyn 4, N.Y.

JFD Electronics-Southern Inc., Oxford, North Carolina
JFD International, 15 Moore Street, New York, N.Y.
JFD Canada, Ltd., 51 McCormack Street, Toronto, Ontario, Canada
557 Richards Street, Vancouver 2, British Columbia

†Attractive, Anti-corrosive Armor

Model LPV-17 (Illustrated)

University of Illinois Develops Space Age Antenna

The theoretical formulation and extensive research which led to the final development of the LPV antenna was a cooperative effort by several outstanding antenna scientists at the Antenna Research Laboratory of the University of Illinois.

Early recognition of the high caliber and originality of these scientists came from the Air Force which awarded several R & D contracts to the University.

Dr. V. H. Rumsey, who headed the Antenna Research Laboratory from 1954 to 1957, directed a large portion of its efforts towards the quest for frequency independence. Professor Rumsey suggested that a logarithmic spiral of infinite length might have characteristics independent of the frequency of operation. Further research by Professors R. H. DuHamel, John D. Dyson, and D. E. Isbell established this theory and also led to the development of a series of finite size antennas which exhibited constant pattern and impedance characteristics independent of frequency over a wide range of frequencies.

The importance of this work soon became obvious with the massive effort devoted by the government to space communications and telemetry. The satellite "Transit" used a modified logarithmic spiral to communicate with our tracking stations from 50 to 400 mc.

In 1957 Professor DuHamel built the first planar Log-Periodic antenna. This was followed in 1959 by Isbell's uniplanar Log-Periodic dipole array. For the next two years, exhaustive tests at the Antenna Research Laboratory were aimed at establishing the properties of the Log-Periodic. It was during this period that Doctors Paul Mayes and R. L. Carrel made their many contributions to the understanding of these antennas and jointly hit upon the V configuration of the dipoles. Tests indicated that this extended the antenna's high directivity from the lowest frequencies covered to the highest.

Professor Mayes subsequently made some modifications in the LPV design so as to make it more suitable for UHF and VHF television coverage.

FROM THIS BEGINNING . . . A NEW ULTIMATE IN TV ANTENNA DESIGN

It was in 1954 that word came out of Urbana, Illinois—the Antenna Research Laboratory of the University of Illinois had "broken through" the bandwidth problem with the log-periodic principle.

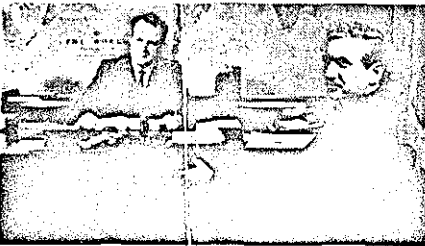

*Professor Mayes and JFD's Ed Finkel
discuss the LPV*

The implications were profound: an antenna that would be essentially frequency-independent, that would set new standards in gain, in bandpass, in front-to-back ratio, that would have an "unidirectional pattern with a directivity comparable to a Yagi array" over bandwidths in excess of 20 to 1.

The Air Force began to apply this new concept to its critical outerspace telemetry needs—and, in 1961, JFD Electronics and the University began discussing home-television applications.

When JFD was granted the exclusive rights to develop, produce and market

the TV antennas based on this principle, the resources of the world's largest antenna manufacturer were galvanized into action. A special force of engineers and researchers went to work. A succession of working models began to appear atop the 135-foot tower of the JFD Antenna Research and Development Center. Exhaustive tests were undertaken, modifications and refinements made, construction details explored.

Now, as a climax to some eight years of study and development, the first of the log-periodic V antennas is here—fulfilling every promise and presaging a revolution in TV antenna design and performance.

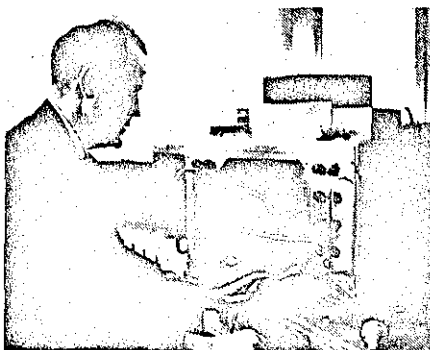

*Professor Mayes at antenna research
laboratory*

13x14-8^{ed}
Look at what else

JFD[®] has going for you!

- 1. Most advanced selections of VHF, UHF, and VHF/UHF/FM antennas.**
 (Also, the most copied.)

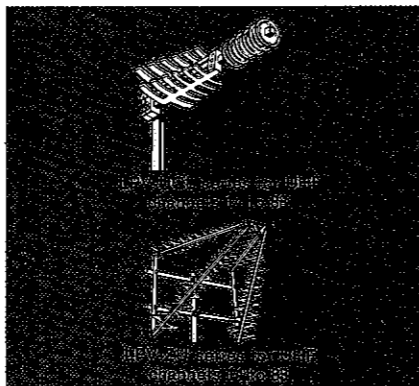
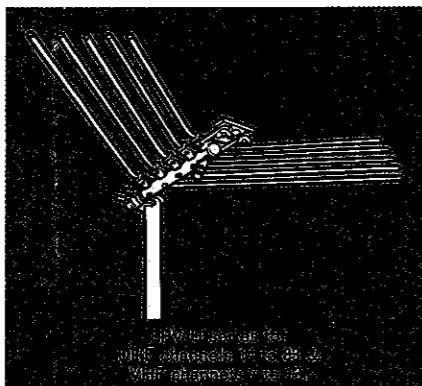
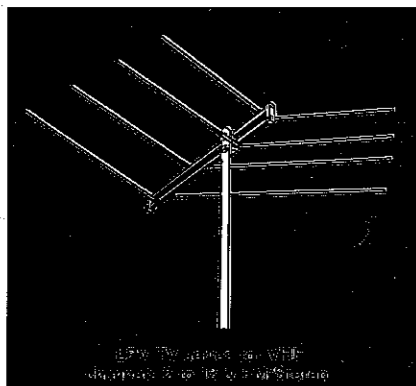
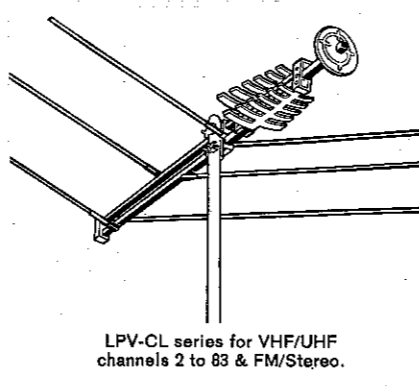
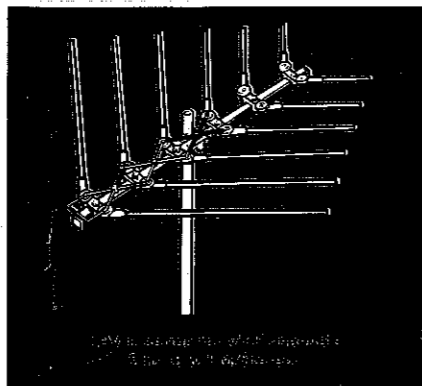
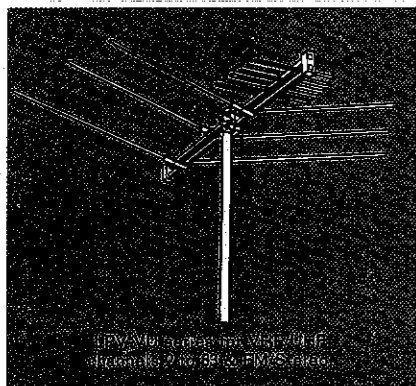

- 2. Scientific engineering under direction of Dr. Paul E. Mayes (co-inventor) of the Log Periodic Antenna concept.**



- 5. Advertised nationally in big space ads in LIFE that pave the way for your local LPV sales.**



- 3. Eleven patents* issued and pending assure you of getting genuine Log Periodic design—not an ineffective imitation.**



- 6. Plus wide selection of 82-channel Amplifiers, Matching Transformers, Splitters and Coaxial Cables.**

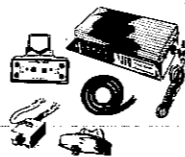

- 4. Eight modern Mobile Field Labs continuously research LPV Log Periodic performance in town and country across the U.S.A.**



- 7. Massive co-op dealer advertising support — newspaper mats, full color motion picture TV commercials, radio jingles.**



* LICENSED UNDER ONE OR MORE OF U.S. PATENTS 2,808,811; 2,808,812; 2,808,813; 2,808,814; 2,808,815; 2,808,816; 2,808,817; 2,808,818; 2,808,819; 2,808,820; 2,808,821; 2,808,822; 2,808,823; 2,808,824; 2,808,825; 2,808,826; 2,808,827; 2,808,828; 2,808,829; 2,808,830; 2,808,831; 2,808,832; 2,808,833; 2,808,834; 2,808,835; 2,808,836; 2,808,837; 2,808,838; 2,808,839; 2,808,840; 2,808,841; 2,808,842; 2,808,843; 2,808,844; 2,808,845; 2,808,846; 2,808,847; 2,808,848; 2,808,849; 2,808,850; 2,808,851; 2,808,852; 2,808,853; 2,808,854; 2,808,855; 2,808,856; 2,808,857; 2,808,858; 2,808,859; 2,808,860; 2,808,861; 2,808,862; 2,808,863; 2,808,864; 2,808,865; 2,808,866; 2,808,867; 2,808,868; 2,808,869; 2,808,870; 2,808,871; 2,808,872; 2,808,873; 2,808,874; 2,808,875; 2,808,876; 2,808,877; 2,808,878; 2,808,879; 2,808,880; 2,808,881; 2,808,882; 2,808,883; 2,808,884; 2,808,885; 2,808,886; 2,808,887; 2,808,888; 2,808,889; 2,808,890; 2,808,891; 2,808,892; 2,808,893; 2,808,894; 2,808,895; 2,808,896; 2,808,897; 2,808,898; 2,808,899; 2,808,900; 2,808,901; 2,808,902; 2,808,903; 2,808,904; 2,808,905; 2,808,906; 2,808,907; 2,808,908; 2,808,909; 2,808,910; 2,808,911; 2,808,912; 2,808,913; 2,808,914; 2,808,915; 2,808,916; 2,808,917; 2,808,918; 2,808,919; 2,808,920; 2,808,921; 2,808,922; 2,808,923; 2,808,924; 2,808,925; 2,808,926; 2,808,927; 2,808,928; 2,808,929; 2,808,930; 2,808,931; 2,808,932; 2,808,933; 2,808,934; 2,808,935; 2,808,936; 2,808,937; 2,808,938; 2,808,939; 2,808,940; 2,808,941; 2,808,942; 2,808,943; 2,808,944; 2,808,945; 2,808,946; 2,808,947; 2,808,948; 2,808,949; 2,808,950; 2,808,951; 2,808,952; 2,808,953; 2,808,954; 2,808,955; 2,808,956; 2,808,957; 2,808,958; 2,808,959; 2,808,960; 2,808,961; 2,808,962; 2,808,963; 2,808,964; 2,808,965; 2,808,966; 2,808,967; 2,808,968; 2,808,969; 2,808,970; 2,808,971; 2,808,972; 2,808,973; 2,808,974; 2,808,975; 2,808,976; 2,808,977; 2,808,978; 2,808,979; 2,808,980; 2,808,981; 2,808,982; 2,808,983; 2,808,984; 2,808,985; 2,808,986; 2,808,987; 2,808,988; 2,808,989; 2,808,990; 2,808,991; 2,808,992; 2,808,993; 2,808,994; 2,808,995; 2,808,996; 2,808,997; 2,808,998; 2,808,999; 2,809,000.

JFD[®] JFD ELECTRONICS CO.
 15th Avenue at 62nd Street, Brooklyn, N. Y. 11219

JFD International, 64-14 Woodside Ave., Woodside, N.Y. 11377 •

JFD de Venezuela, S.A., Avenida Los Haticos 125-97, Maracaibo, Venezuela

68

13x14-8^{ed}
get with the

JFD[®]

UNITED STATES DISTRICT COURT
 NORTHERN DISTRICT OF ILLINOIS
 BEFORE JUDGE HOFFMAN
 DEFENDANT EX. NO. 38
 DOROTHY L. BRACKENBURY
 OFFICIAL COURT REPORTER

camp

*Color Antenna Merchandising Program

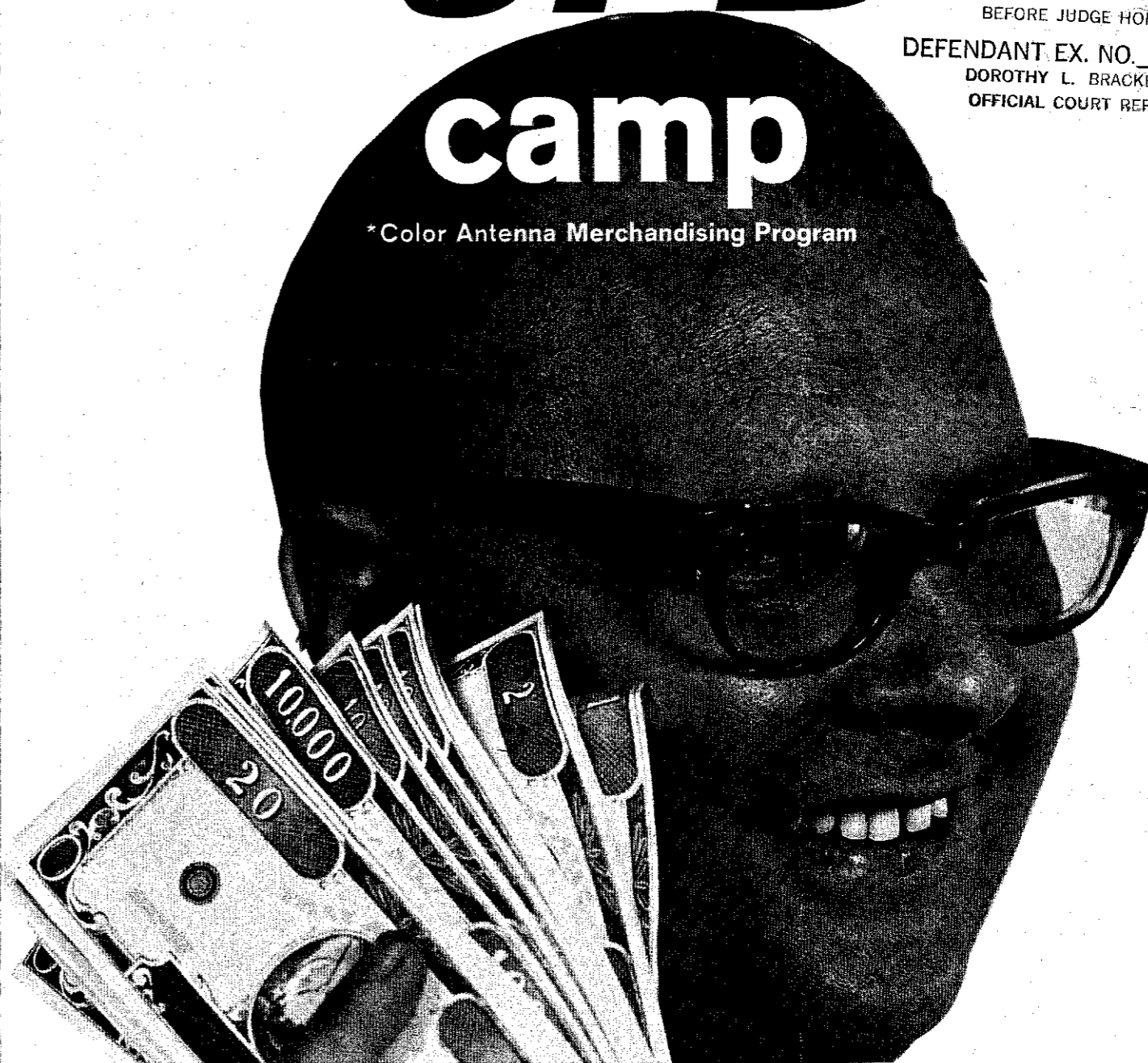

—the most spectacular retail sales promotion campaign in TV antenna history!

Sure you're doing great selling color TV sets. But if you're skipping the color antenna sale that goes with it, you're passing up "beaucoup" profits. Too risky and tricky, you say? That was B. C. (Before CAMP) which now "automates" the color antenna sale—earns **you** (instead of your competition) those extra profits. Keeps **customers** happy, too. How? Easy. CAMP coordinates a comprehensive combination of dynamic selling tools that (1) drive home the fact that only a **color-engineered** TV antenna can do justice to the fine reception color TV sets were designed for and that (2) JFD LPV COLOR LPV Log Periodic antennas make color sets work at their very **best**.

Turn the page and see how the JFD CAMP takes the mystery **out** of TV antenna business—and puts back the **profits**.

JUST WHAT IS CAMP? Camp is a popular new expression meaning anything done in a style that is different or unusual enough to be considered "in" and attention-getting—a most apt definition of JFD's own (CAMP) Color Antenna Merchandising Program.

65

turn your store
into a

camp site-

where the antenna action is!

NOW—CAMP MAKES TV ANTENNAS

AS EASY TO SELL AND INSTALL

AS A WASHING MACHINE

—MORE PROFITABLE, TOO!

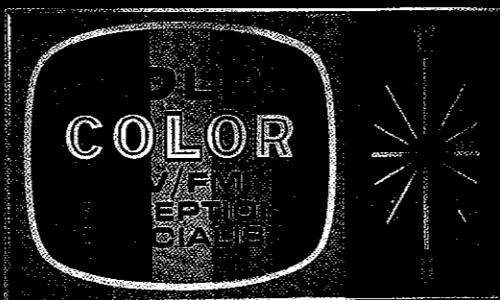

*Color Antenna Merchandising Program

how to get with the

JFD[®] camp*

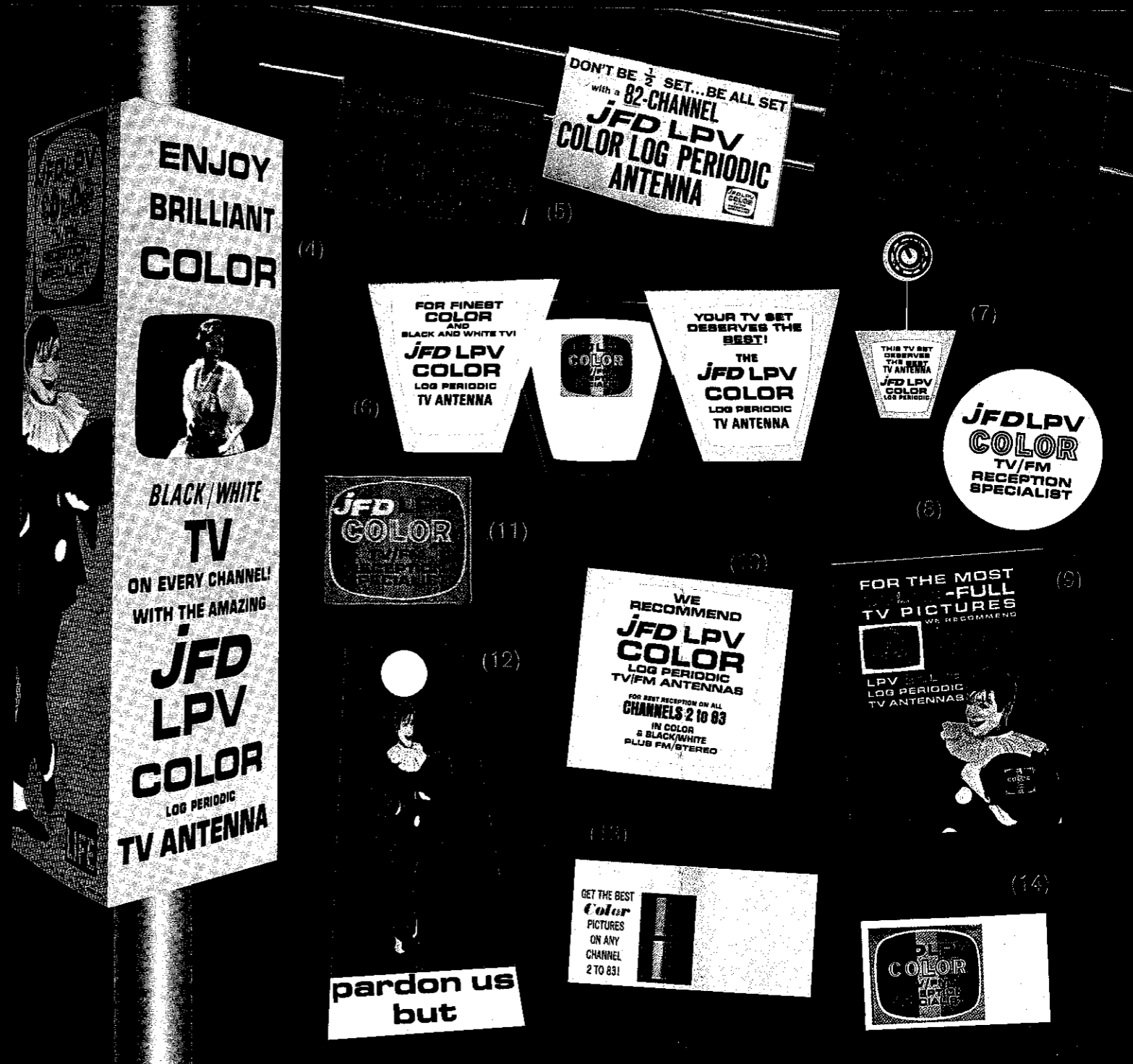

Camp pre-sells prospects — CAMP goes to work pre-conditioning prospects the moment they stop by or step into your showroom. Colorful window decals (1) and bright fluorescent signs (2) identify you as a Color TV Reception Specialist. Gleaming gold-alodized antenna displays (3) stop traffic and start the sale. Antenna mast sleeve (4) Colorful pennants (5) and mobiles (6) lend a festive air. Miniature danglers (7) on TV sets call attention to the fact that color sets work better with a color-engineered JFD LPV TV antenna. Provocative button (8) invites questions and breaks down resistance. Lavish full-color brochure (9) lets you follow through by showing customers (in three minutes flat) why their new color TV deserves a modern new LPV Color Antenna by JFD.

Camp works outside, too — Big full-color truck decals (10) tell the world you are the Color TV Reception Specialist for the area. So do equally colorful arm patches (11). Compelling door-knob hangers (12) alert obsolete antenna owners to your expert color service. Make your own personalized direct mail advertising campaign using full-color self-mailers (13) and (14). Interested? A call to your JFD LPV distributor puts you in the winning CAMP. See him today and watch your antenna profits G-R-O-W!

Why Play Antenna Roulette? Rely On JFD for the Best Antennas and the Best Promotions.

XB14 a-c

BX14 - b

70 MILLION FAIR VISITORS WILL SEE AND HEAR ABOUT

PATENTED THE LOG-PERIODIC LPV - THE EXCLUSIVE CHOICE OF TV SETS

4
B15

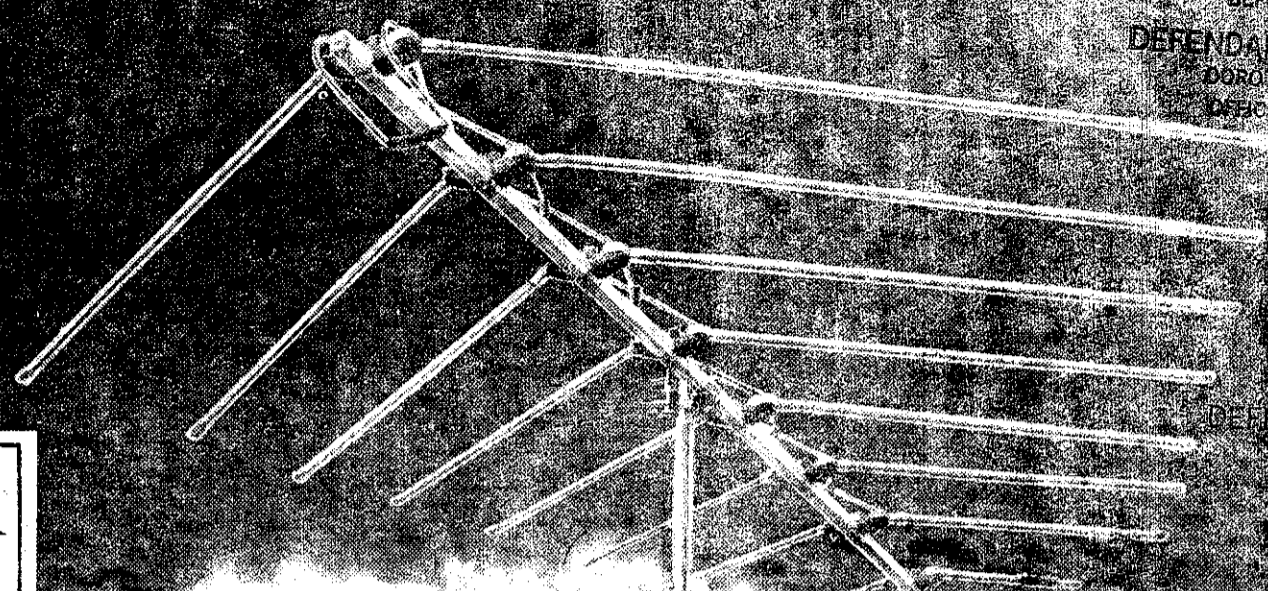

UNITED STATES DISTRICT COURT
NORTHERN DISTRICT OF ILLINOIS
BEFORE JUDGE HOFFMAN
DEFENDANT EX. NO. 36
DOROTHY L. BRACKENBURY
OFFICIAL COURT REPORTER



UNITED STATES DISTRICT COURT
NORTHERN DISTRICT OF ILLINOIS
BEFORE JUDGE HOFFMAN
DEFENDANT EX. NO. 36
DOROTHY L. BRACKENBURY
OFFICIAL COURT REPORTER

Now — the antenna designed to meet satellite telemetry needs has been adapted by JFD to help you and your customers get far better reception in COLOR, black/white, and FM!

A NEW PERFORMANCE PROVED LOG PERIODIC LPV (VHF, UHF, VHF-UHF, FM STEREO)... EVERY PROBLEM (GHOSTS, EVERY LOCATION (LOCAL, SUBURBAN, & FRINGE) SOLVED. MARKETS FOR ALL DEALERS!

Improvements of University of Illinois Laboratories are NOW translated into finer Pictures, Clearer FM Stereo!

This means far fewer service calls... far more customer satisfaction with what you sell... far greater profits at the end of year. And, the World's Fair will dramatically demonstrate this antenna to 70 million Fair-goers in 1964 and 1965!

Cash in starting now on the profit opportunity of the year!

The space-age Log Periodic principle of the Antenna Research Laboratories of the University of Illinois has been acclaimed as the most significant antenna discovery since the invention of the Yagi. This patented Log Periodic concept—adapted by the JFD Research and Development Laboratories in Champaign, Illinois—is now available in a unique new line of LPV antennas for VHF, UHF and FM stereo.

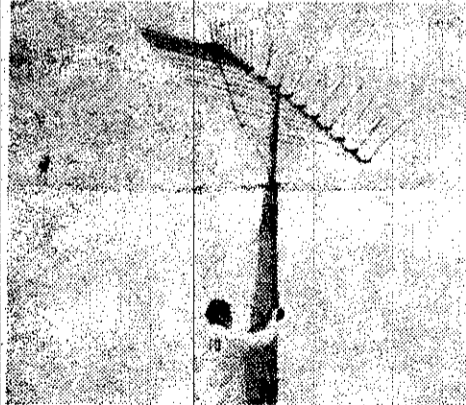

The secret is in its frequency-independent design. All elements are designed according to the patented log periodic formula. They all work like a powerful tuned multi-element Yagi—not on just one or a few channels as do other antennas—but on all channels across the band.

The result is far superior gain, directivity, front-to-back ratio, and VSWR that lights up

the weakest, ghostiest TV image with sparkling detail and contrast—for superb color, as well as black and white pictures—plus fidelity FM stereo!

Model LPV11 illustrated for fringe areas
This LPV TV antenna series, the first ever to utilize the revolutionary Log Periodic concept, opened a new era in TV/FM performance... Gold Alodized VHF Log Periodic LPV TV ANTENNAS for channels 2 to 13 plus FM Stereo (available in 6 area-engineered models)

Model LPV-U9 illustrated for local & suburban
Here's an all new UHF series employing Log Periodic design to provide the high-gain, ghost-free signal needed especially by UHF sets for sharp, steady pictures on channels 14 to 83 and channels 7 to 13. Prepares you now with the antenna you need to cash in on the great new UHF market.
Gold Alodized UHF Log Periodic LPV TV ANTENNAS for channels 14 to 83 plus VHF channels 7 to 13 (available in 4 area-engineered models)

Model LPV-2510 illustrated
Tomorrow's antenna today. The most advanced application of the Log-Periodic formula—receives all FCC authorized television channels on VHF (2 to 13) on UHF (14 to 83) plus all FM and FM Stereo Frequencies. This is the first single all-channel antenna using a single down-lead to achieve this performance.

Model LPV-VU15 for suburban-fringe areas illustrated
break-through! (Includes VHF-UHF Splitter for separate lead-ins to VHF and UHF set terminals.)
Gold-Alodized VHF-UHF Log-Periodic LPV ANTENNAS for channels 2 to 83 plus FM Stereo (soon available in 4 models)

THERE IS ONLY ONE GENUINE PATENTED LOG-PERIODIC V-ANTENNA

JFD LPV

Only JFD is licensed exclusively by the University of Illinois Foundation to make the patented Log-Periodic LPV and all other Log-Periodic type TV and FM antennas. No other so-called Log-Periodic antenna can work like the JFD Log-Periodic LPV because only JFD uses the original patented Log-Periodic design formula of the Antenna Research Laboratories of the University of Illinois. Rely on the JFD LPV and see why at the moment of truth, the picture is the proof—that the LPV works best! Now in stock at your JFD distributor.

LICENSED UNDER ONE OR MORE OF U.S. PATENTS 2,958,081; 2,985,879; 3,011,168; 3,108,280 AND ADDITIONAL PATENTS PENDING IN U. S. A. AND CANADA. PRODUCED BY JFD ELECTRONICS CORPORATION UNDER EXCLUSIVE LICENSE FROM THE UNIVERSITY OF ILLINOIS FOUNDATION.

Copyright JFD Electronics Corp. 1964

THE KNOW-HOW OF THE WORLD'S NEWEST AND FINEST ANTENNA LABORATORIES IS BUILT INTO EACH JFD LPV ANTENNA YOU SELL!



The Log-Periodic concept is the result of five years of intensive electronic studies at the Antenna Research Laboratories of the University of Illinois and JFD. Located in Champaign, Illinois (home of the University of Illinois), the vast new JFD research center is the largest and most complete of its kind.

Professor Paul Mayes of the Antenna Research Laboratories of the University of Illinois, originator of the log-periodic V-dipole antenna concept.

B15
all

OUT THIS REMARKABLE NEW JFD TV/FM ANTENNA!

THE NEW YORK WORLD'S FAIR HOUSE OF GOOD TASTE!

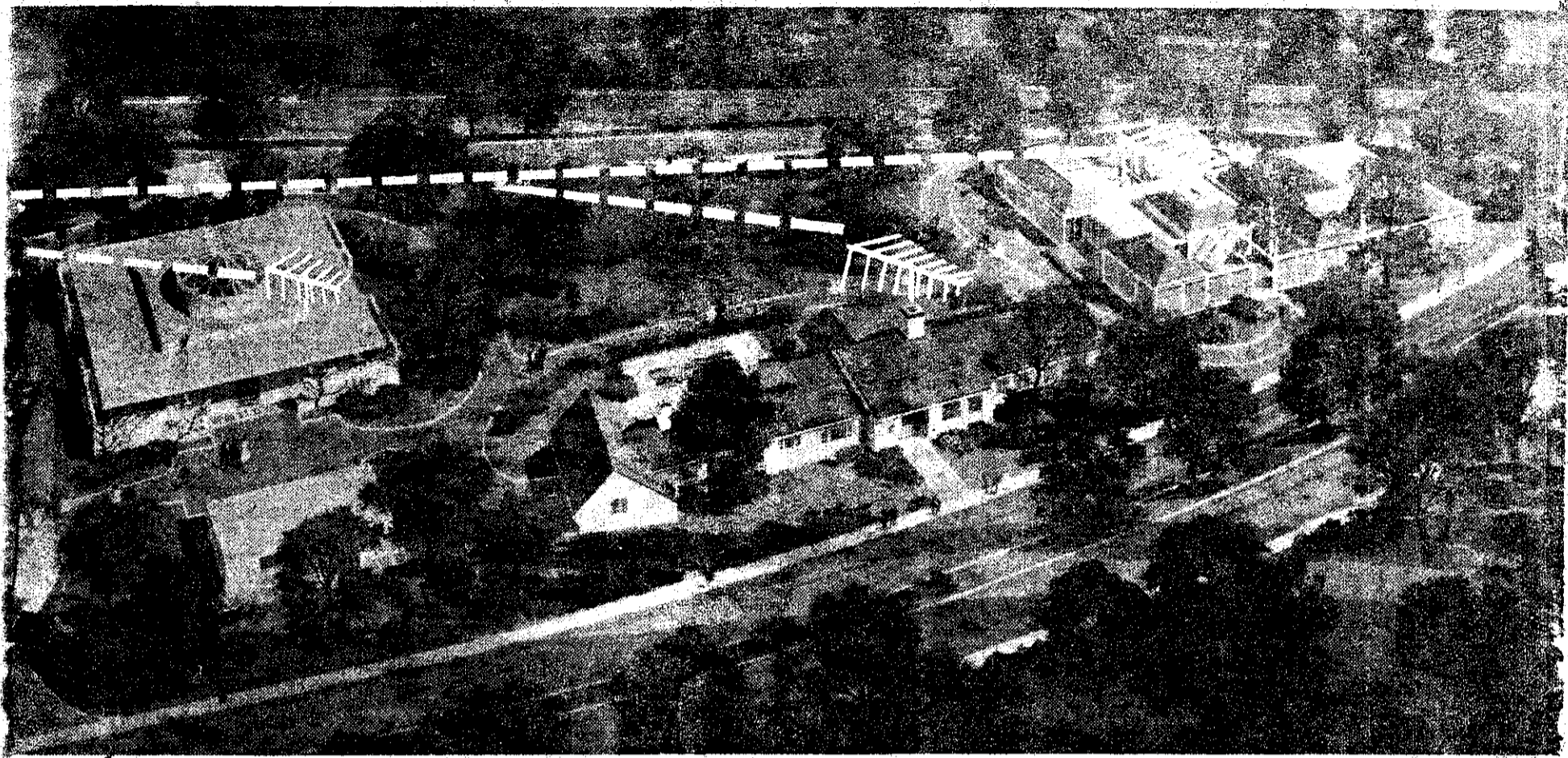

EVERY BAND (VHF, OR INTERFERENCE)...
PROFITABLE NEW

You Win All Ways When You Feature The JFD LOG PERIODIC LPV!

1. Exclusive Log Periodic demonstration in one of the Fair's chief exhibits—The House of Good Taste!
2. Free dealer holiday at the fabulous New York World's Fair!
3. Tremendous sales impact of World's Fair tie-in publicity, promotion and advertising!

In 1964 and 1965, JFD puts the prestige and drawing power of the biggest attraction of all time behind every JFD Log Periodic LPV TV/FM antenna you sell—the New York World's Fair!

—AND TO HELP YOU SELL MORE LPV LOG PERIODIC ANTENNAS, JFD OFFERS YOU A SENSATIONAL WORLD'S FAIR TIE-IN PROMOTION



suburban areas

This exotic all-new UHF series obsoletes bulky parabolics and stacked bowtie-reflector and corner reflector antennas. Packs more long-distance pick-up sensitivity per element. Another ahead-of-the-industry antenna advance that puts you in command of new UHF antenna business in your town.

Gold Alodized UHF Log Periodic Planar Helical ZAGI TV ANTENNAS for channels 14 to 83 (available in 2 area-engineered models)

Model LPT100 illustrated Never before an indoor antenna like this. The first ever engineered according to the patented log-periodic formula. Actually outperforms some roof-top UHF antennas. Tunes itself electronically (without switches) to desired channel. Gold Alodized INDOOR UHF Log Periodic Trapezoid TV ANTENNA for channels 14 to 83

to be used in its showcase of the finest in

This powerful new marketing force will be at work behind every JFD Log Periodic LPV Sales and profits for you!

PLUS!—

Every JFD VHF, UHF or VHF-UHF Log-Periodic LPV you buy between March 1, 1964 and August 31, 1965 earns you valuable JFD Fair Festival Certificates which you can:

1. Trade in for FREE World's Fair Adult Admission Tickets (worth 150 points) or . . .
2. Trade in for FREE 3-day, 2-night Fair week-end holiday (worth 3,000 points) or . . .
3. Redeem for \$1.25 cash for each 150 points, from JFD.

JFD Dealer Point Values for Log Periodic Antennas:

Model	Points	Model	Points
LPV17	60	LPV-U15	20
LPV14	50	LPV6, LPV6PM	15
LPV11	35	LPV4, LPV-4PM	10
LPV-U21	30	LPV-U9	10
LPV8, LPV8PM	25	LPV-U5	5

IT'S THE PROFIT/ENTERTAINMENT OPPORTUNITY OF THE YEAR!



AT THE MOMENT OF TRUTH, THE PICTURE IS THE PROOF THE JFD LOG-PERIODIC LPV WORKS BEST!

INSIST ON JFD LOG-PERIODICS WITH THE EQUIPMENT YOU SELL FOR MORE SALES AND PROFITS!

Write for complete details or see your JFD LPV distributor today!

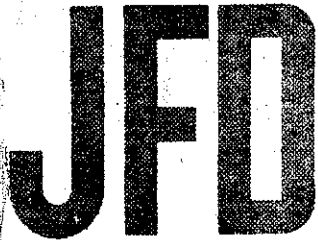

JFD ELECTRONICS CORPORATION
15th Avenue at 62nd Street, Brooklyn, N. Y. 11219
JFD Electronics Southern Inc., Oxford, North Carolina
JFD International, 64-14 Woodside Ave., Woodside 77, N. Y.
JFD Canada, Ltd., 51 McCormack Street, Toronto, Ontario, Canada
401-144 W. Hastings Street, Vancouver 3, B. C.

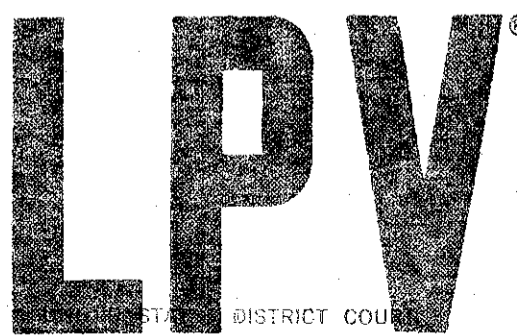

ADVERTISED IN
LOOK / Sunset

DISTRICT COU
NORTHERN DISTRICT OF ILLINOIS
BEFORE JUDGE HOFFMAN
DEFENDANT EX. NO.
DOROTHY L. BRACKENBURY
OFFICIAL COURT REPORTER