

United States District Court,
E.D. Michigan, Southern Division.

NEWFREY, LLC, et al,
Plaintiffs.

v.

BURNEX CORPORATION,
Defendant.

Dec. 10, 2008.

Background: Assignee and licensee filed action against competitor alleging infringement of patents for fasteners or clips. Court set forth to construe disputed claims.

Holdings: The District Court, Avern Cohn, J., held that:

(1) phrase, "a generally straight portion," meant portion that was straight but not necessarily precisely 180 degrees;

(2) phrase, "extending continuously," meant extending without break;

(3) phrase, "being defined by an exterior convex surface," meant given form by exterior convex surface;

(4) phrase, "a pair of elastic abutting flanges outwardly extending into an aperture in each said top flange member," meant pair of elastic abutting flanges extending outwardly into aperture in each top flange;

(5) phrase, "a first pair of spaced apart finger members integrally formed with each said top flange member; and," meant first pair of spaced apart fingers integrally formed with each top flange;

(6) phrase, "a second pair of spaced apart finger members integrally formed with each said side wall, and," meant second pair of spaced apart fingers integrally formed with each side wall;

(7) phrase, "wherein said finger members cross said centerline, and," meant second pair of spaced apart fingers crossed centerline; and

(8) phrase, "wherein said pairs of finger members inwardly extend into said body of the fastener and are configured to grippingly engage the coupling flange," meant first and second pair of fingers extend inwardly into the body of the fastener and are configured to engage the coupling flange by gripping it.

Ordered accordingly.

6,928,705, 7,096,638, 7,120,971. Construed.

George D. Moustakas, Harness, Dickey, Troy, MI, for Plaintiffs.

John E. Nemazi, Robert C. Brandenburg, Robert C.J. Tuttle, Brooks Kushman, Southfield, MI, for Defendant.

MARKMAN CLAIM CONSTRUCTION ORDER

AVERN COHN, District Judge.

TABLE OF CONTENTS

I.	Introduction	530
II.	Background	531
A.	The '705 Patent	531
1.	Abstract and Summary	531
2.	Paradigm Claim 1	532
B.	The '638 Patent	533
1.	Abstract and Summary	533
2.	Paradigm Claim 1	534
C.	The '971 Patent	535
1.	Abstract and Summary	535
2.	Paradigm Claim 20	536
III.	Legal Standards	537
IV.	Analysis	539
A.	Introduction	539
1.	Specifications	539
2.	Prosecution Histories	539
3.	Additional Observations	539
B.	The '705 Patent: Claim 1 Terms	540
1.	"a generally straight portion"	540
2.	"an exterior concave surface immediately abutting the exterior convex surface of the transition portion and extending continuously from the transition portion"	541
a.	"immediately abutting"	541
b.	"extending continuously"	542
3.	"the exterior concave engaging surface having a radius between 3.5 millimeters and 6.0 millimeters"	542
C.	The '638 Patent: Claim 1 Terms	542
1.	"a generally straight portion"	542
2.	"the transition portion"	542
3.	"being defined by an exterior convex surface"	542
4.	"an exterior concave surface substantially abutting the exterior convex surface of the transition portion"	543
D.	The '971 Patent: Claim 20 Terms	544
1.	"a pair of elastic abutting flanges ... outwardly extending ... into an aperture in each said top flange member"	544
2.	"a first pair of spaced apart finger members integrally formed with each said top flange member; and"	544
3.	"a second pair of spaced apart finger members integrally formed with each said side wall, and"	545
4.	"wherein the base portion and opposed sidewalls define a centerline and"	545

5. "wherein said finger members cross said centerline, and" 545

6. "wherein said pairs of finger members inwardly extend into said body of the fastener
and are configured to grippingly engage the coupling flange" 546

V. Conclusion 547

I. Introduction

This is a patent case. Plaintiffs Newfrey LLC (Newfrey) and Emhart Teknologies LLC (Emhart) complain that defendant Burnex Corp. (Burnex) has infringed three patents for fasteners or clips for which Newfrey is assignee and Emhart is licensee. The patents in suit are United States Patent Nos. 6,928,705, Low Insertion Effort U-Base Retainer, issued August 16, 2005 (the '705 patent); 7,096,638, Low Insertion Effort U-Base Retainer, issued August 29, 2005 (the '638 patent); and 7,120,971, Low Insertion Effort U-Base Retainer, issued October 17, 2006 (the '971 patent). FN1 The patents cover a resilient U-based clip for attaching a trim piece or panel to the structure of a motor vehicle. The clip is in one piece and is spring biased. There are three accused clips commonly known as '11, '32, and '50, which generally sell for under \$1.00 a piece.

FN1. All three patents stem from provisional application no. 60/272,992, filed March 2, 2001. The application for the '791 patent, filed Sept. 2, 2003, was the 35 U.S.C. s. 371 national stage entry for application PCT/US02/06753, filed March 4, 2002. The application for the '638 patent, filed May 30, 2003, was a continuation-in-part (CIP) of application PCT/US02/06753. The application for the '705 patent, filed July 28, 2003, was a continuation of application PCT/US02/06573.

The paradigm claims are: Claim 1 of the '705 patent, Claim 1 of the '638 patent, and Claim 20 of the '971 patent. Before the Court are the parties' claim construction briefs relating to interpretation of the ambiguous words and phrases in the paradigm claims under Markman. FN2 The Court has also heard oral arguments on the parties' constructions. For the most part, Newfrey says that the ambiguous terms are not in need of interpretation or should be interpreted according to their ordinary meaning, particularly referring to standard dictionary definitions. Burnex says that the prosecution history defines the meaning of the terms in question, resulting in different and, in most cases, more restrictive interpretations than the standard dictionary definitions.

FN2. *Markman v. Westview Instruments, Inc.*, 52 F.3d 967, 979 (Fed.Cir.1995) (en banc), *aff'd*, 517 U.S. 370, 116 S.Ct. 1384, 134 L.Ed.2d 577 (1996); *see* The Sedona Conference Report on the Markman Process, June 2006 Public Comment Version, *available at* www.the-sedona-conference.org.

The respective positions of the parties are displayed in the claim charts attached as Exhibits A, B, and C. The exhibits also depict the constructions by the Court that govern further proceedings in this case. As the Court has repeatedly observed, claim construction in a Markman proceeding is tentative and its conclusions are open to change as the case unfolds in the validity and infringement phases.

II. Background

A. The '705 Patent

1. Abstract and Summary

The Abstract describes the invention:

A resilient clip for engaging a structure and having a body portion (22) with a pair of top flanges (24), a pair of fastening fingers (26) and a pair of abutting coupling flanges (28). Each of the fastening fingers (26) are coupled to the body portion (22) that is coupled to an associated top flange (24). Each of the abutting flanges (26 FN3) has a concave surface, which engages the mounting structure. The fastening finger (26) portions are configured to engage a first side of a mounting flange on an interior trim component.

FN3. This should doubtless read 28.

The Summary of the Invention reads:

In one preferred form, the present invention provides a resilient clip for engaging a structure. The resilient clip includes a body portion having a pair of top flanges, a pair of fastening members and a pair of abutting flanges. Each of the fastening members has a base portion that is coupled to an associated top flange. Each of the abutting flanges has a concave surface that engages the mounting structure.

A perspective view of a fastener constructed in accordance with the teachings of the invention is depicted in Figure 1 of the '705 patent, FN4 shown below:

FN4. All three patents in suit use the same Figure 1.

***532**

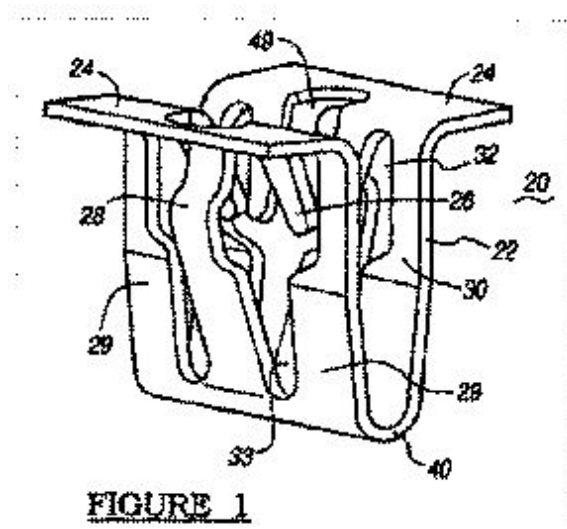

FIGURE 1

2. Paradigm Claim 1

Paradigm Claim 1, broken down into appropriate clauses, reads:

1. A generally U-shaped fastener adapted to mount an object to a panel, the panel including a mounting aperture therein, the fastener comprising:

a body portion having a pair of side members coupled to each other by a curved base portion at an insertion end of the generally U-shaped fastener, the pair of side members defining a slot between the pair of side members, the slot being adapted to receive a coupling member from the object;

a flange member extending outwardly from each of the pair of side members near an end opposite the insertion end of the generally U-shaped fastener, each flange member being adapted to contact a surrounding portion of the mounting aperture;

a plurality of finger members extending inwardly into the slot at an angle into the slot from each of the pair of side members or from the flange members, the plurality of finger members being adapted to grasp the coupling member of the object upon the coupling member being inserted into the slot; and

at least one abutting flange extending outwardly from each of the pair of side members, each of the at least one abutting flange having a *generally straight portion*, a transition portion and an engaging portion, the generally straight portion coupling the at least one abutting flange to one of the side members near the insertion end of generally U-shaped fastener, the transition portion being coupled to the generally straight portion and being defined by an exterior convex surface, the engaging portion having an *exterior concave surface immediately abutting the exterior convex surface of the transition portion and extending continuously from the transition portion, the exterior concave engaging surface having a radius between 3.5 millimeters and 6.0 millimeters* and being adapted to engage an edge of the mounting aperture upon insertion therein to retain the generally U-shaped fastener in the mounting aperture.

The underlined terms require interpretation by the Court. Figure 15B of the '705 patent, shown below, gives a cross-sectional view of the fastener detailing the radius R of the exterior concave surface 150.

*533

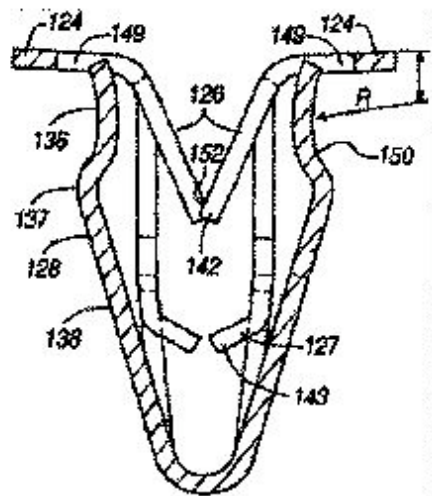

FIGURE 15B
SECTION C C

FIGURE 15B

SECTION CC

The chart, submitted jointly by the parties, has three component parts in need of interpretation, as follow:

- (1) a generally straight portion
- (2) an exterior concave surface immediately abutting the exterior convex surface of the transition portion and extending continuously from the transition portion
- (3) the exterior concave engaging surface having a radius between 3.5 millimeters and 6.0 millimeters

B. The '638 Patent

1. Abstract and Summary

The Abstract describes the invention:

A resilient clip for engaging a structure and having a body portion 22 with a pair of top flanges 24, a pair of fastening fingers 26 and a pair of abutting coupling flanges 28. Each of the fastening fingers 26 are coupled to the body portion 22 that is coupled to an associated top flange 24. Each of the abutting flanges 26 FN5 has a concave surface, which engages the mounting structure. The fastening finger 26 portions are configured to engage a first side of a mounting flange on an interior trim component. An optional sealing member 122 may be used to provide sealing engagement.

FN5. Supra note 3.

The Summary of the Invention reads:

In one preferred form, the present invention provides a resilient clip for engaging a structure. The resilient clip includes a body portion having a pair of top flanges, a pair of fastening members and a pair of abutting flanges. Each of the fastening members has a base portion that is coupled to an associated top flange. Each of the abutting flanges has a concave surface that engages the mounting structure. A sealing member is disposed about the top of the resilient clip to provide sealing engagement with at least a portion of the structure.

A perspective view of a fastener constructed in accordance with the teachings of an embodiment of the invention featuring an optional seal is depicted in Figure 22 of the '638 patent, shown below:

***534**

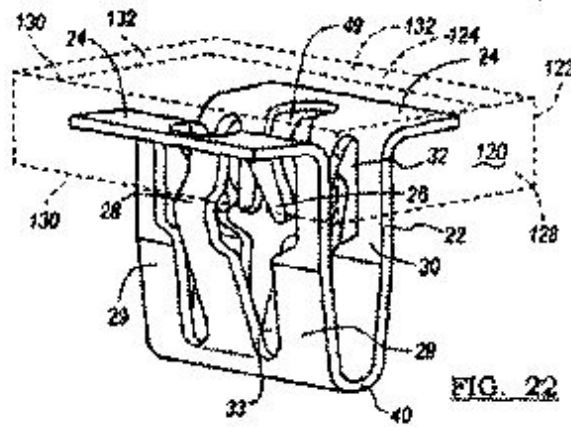

FIGURE 22

2. Paradigm Claim 1

Paradigm Claim 1, broken down into appropriate clauses, reads:

1. A generally U-shaped fastener adapted to mount an object to a panel, the panel including a mounting aperture therein, the fastener comprising:

a body portion having a pair of side members coupled to each other by a curved base portion at an insertion end of the generally U-shaped fastener, the pair of side members defining a slot between the pair of side members, the slot being adapted to receive a coupling member from the object;

a flange member extending outwardly from each of the pair of side members near an end opposite the insertion end of the generally U-shaped fastener, each flange member being adapted to contact a surrounding portion of the mounting aperture;

a plurality of finger members extending inwardly into the slot from each of the pair of side members or from the flange members, the plurality of finger members being adapted to grasp the coupling member of the object upon the coupling member being inserted into the slot; and

at least one abutting flange extending outwardly from each of the pair of side members, each of the at least one abutting flange having a *generally straight portion*, a transition portion and an engaging portion, the generally straight portion coupling the at least one abutting flange to one of the side members near the insertion end of generally U-shaped fastener, *the transition portion* being coupled to the generally straight portion and *being defined by an exterior convex surface*, the engaging portion having *an exterior concave surface substantially abutting the exterior convex surface of the transition portion*; the engaging portion being adapted to engage an edge of the mounting aperture upon insertion therein to retain the generally U-shaped fastener in the mounting aperture.

The underlined terms require interpretation by the Court. A side view of an embodiment of the fastener showing the three portions 136, 137 and 138 of the abutting flange is depicted in Figure 15 of the '638 patent, shown below:

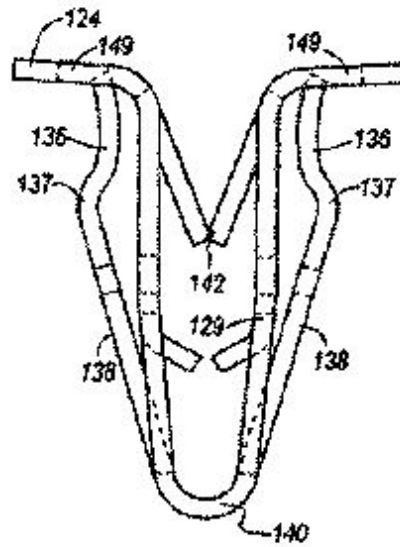

FIG. 15

FIGURE 15

The chart, submitted jointly by the parties, has three component parts in need of interpretation, as follow:

- (1) a generally straight portion
- (2) the transition portion ... being defined by an exterior convex surface
- (3) an exterior concave surface substantially abutting the exterior convex surface of the transition portion

C. The '971 Patent

1. Abstract and Summary

The Abstract describes the invention:

A resilient clip for engaging a structure and having a body portion (22) with a pair of top flanges (24), a pair of fastening fingers (26) and a pair of abutting coupling flanges (28). Each of the fastening fingers (26) are coupled to the body portion (22) that is coupled to an associated top flange (24). Each of the abutting flanges (26 FN6) has a concave surface, which engages the mounting structure. The fastening finger (26) portions are configured to engage a first side of a mounting flange on an interior trim component.

FN6. Supra note 3.

The Summary of the Invention reads:

In one preferred form, the present invention provides a resilient clip for engaging a structure. The resilient clip includes a body portion having a pair of top flanges, a pair of fastening members and a pair of abutting

flanges. Each of the fastening members has a base portion that is coupled to an associated top flange. Each of the abutting flanges has a concave surface that engages the mounting structure.

Figure 12 of the '971 patent, shown below, depicts two pair of first finger member 126 and a pair of second finger member 127 in accordance with a second embodiment of the invention.

*536

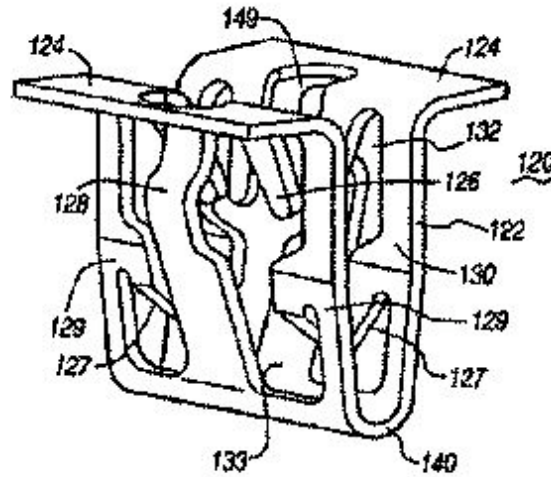

FIGURE 12

FIGURE 12

2. Paradigm Claim 20

Paradigm Claim 20, broken down into appropriate clauses, reads:

20. A fastener for removably mounting a coupling flange in a panel aperture, the fastener comprising:

a base portion;

two opposing side walls integrally connected to said base portion and forming a substantially U-shaped body, each said side wall having an outwardly extending top flange member;

a pair of elastic abutting flanges integrally formed with and outwardly extending from said base portion and into an aperture in each said top flange member;

a first pair of spaced apart finger members integrally formed with each said top flange member; and

a second pair of spaced apart finger members integrally formed with each said side wall, and wherein the base portion and opposed sidewalls define a centerline and wherein said finger members cross said centerline, and

wherein said pairs of finger members inwardly extend into said body of the fastener and are configured to

grippingly engage the coupling flange.

The underlined terms require interpretation by the Court.

The chart, submitted jointly by the parties, has six component parts in need of interpretation, as follow:

- (1) a pair of elastic abutting flanges ... outwardly extending ... into an aperture in each said top flange member
- (2) a first pair of spaced apart finger members integrally formed with each said top flange member; and
- (3) a second pair of spaced apart finger members integrally formed with each said side wall, and
- (4) wherein the base portion and opposed sidewalls define a centerline and
- (5) wherein said finger members cross said centerline, and
- (6) wherein said pairs of finger members inwardly extend into said body of the fastener and are configured to grippingly engage the coupling flange

III. Legal Standards

[1] [2] [3] Claim construction FN7 is a matter of law for the Court. *Markman v. Westview Instruments, Inc.*, 52 F.3d 967, 979 (Fed.Cir.1995) (en banc), *aff'd*, 517 U.S. 370, 116 S.Ct. 1384, 134 L.Ed.2d 577 (1996). The focus is on "what one of ordinary skill in the art at the time of the invention would have understood the term to mean." *Id.* at 986.

FN7. The Court refers to the process of determining the meaning of a claim as claim "construction." The Court uses the term "interpret" to describe the process of construing the meaning of a limitation, phrase, word, or element of a claim where the meaning is not clear or is ambiguous. Lack of clarity is synonymous with ambiguity.

Importantly, the person of ordinary skill in the art is deemed to read the claim term not only in the context of the particular claim in which the disputed term appears, but in the context of the entire patent, including the specification. This court explained that point well in *Multiform Desiccants, Inc. v. Medzam, Ltd.*, 133 F.3d 1473, 1477 (Fed.Cir.1998):

It is the person of ordinary skill in the field of the invention through whose eyes the claims are construed. Such person is deemed to read the words used in the patent documents with an understanding of their meaning in the field, and to have knowledge of any special meaning and usage in the field. The inventor's words that are used to describe the invention-the inventor's lexicography-must be understood and interpreted by the court as they would be understood and interpreted by a person in that field of technology. Thus the court starts the decision making process by reviewing the same resources as would that person, viz., the patent specification and the prosecution history.

See also Medrad, Inc. v. MRI Devices Corp., 401 F.3d 1313, 1319 (Fed.Cir.2005) ("We cannot look at the ordinary meaning of the term ... in a vacuum. Rather, we must look at the ordinary meaning in the context of the written description and the prosecution history."); *V-Formation, Inc. v. Benetton Group SpA*, 401 F.3d 1307, 1310 (Fed.Cir.2005) (the intrinsic record "usually provides the technological and temporal context to enable the court to ascertain the meaning of the claim to one of ordinary skill in the art at the time of the invention"); *Unitherm Food Sys., Inc. v. Swift-Eckrich, Inc.*, 375 F.3d 1341, 1351

(Fed.Cir.2004) (proper definition is the "definition that one of ordinary skill in the art could ascertain from the intrinsic evidence in the record").

Phillips v. AWH Corp., 415 F.3d 1303, 1313-14 (Fed.Cir.2005).

[4] [5] [6] [7] The first step in construing a patent claim is to examine the intrinsic evidence:

First, we look to the words of the claims themselves, both asserted and nonasserted, to define the scope of the patented invention. Although words in a claim are generally given their ordinary and customary meaning, a patentee may choose to be his own lexicographer and use terms in a manner other than their ordinary meaning, as long as the special definition of the term is clearly stated in the patent specification or file history.

Thus, second, it is always necessary to review the specification to determine whether the inventor has used any terms in a manner inconsistent with their ordinary meaning. The specification acts as a dictionary when it expressly defines terms used in the claims or when it defines terms by implication.... The specification contains a written description of the invention which must be clear and complete enough to enable those of ordinary skill in the art to make and use it. Thus, the specification is always highly relevant to the claim construction analysis. Usually, it is dispositive; it is the single best guide to the meaning of a disputed term.

Third, the court may also consider the prosecution history of the patent, if in evidence. This history contains the complete record of all the proceedings before the Patent and Trademark Office, including any express representations made by the applicant regarding the scope of the claims. As such, the record before the Patent and Trademark Office is often of critical significance in determining the meaning of the claims. Included within an analysis of the file history may be an examination of the prior art cited therein.

Vitronics Corp. v. Conceptronic, Inc., 90 F.3d 1576, 1582-83 (Fed.Cir.1996) (citations omitted).

This Court has previously articulated the law on the role of the specification and prosecution history in determining a claim term's meaning, stating:

Ordinary meaning ... is not the end of the analysis; the specification and prosecution history must also be studied to determine if it is appropriate to afford a claim term its ordinary meaning. Kumar v. Ovonic Battery Co., 351 F.3d 1364, 1367-68 (Fed.Cir.2003).... [I]n certain situations, the specification or prosecution history may show an intent to depart from the ordinary meaning of a claim term. CCS Fitness, Inc. v. Brunswick Corp., 288 F.3d 1359, 1366-67 (Fed.Cir.2002). For example, the patentee may act as his own lexicographer and explicitly define a term in the specification or prosecution history. *Id.* The patentee may also characterize "the invention in the intrinsic record using words or expressions of manifest exclusion or restriction, representing a clear disavowal of claim scope." Teleflex, Inc. v. Ficosa North America Corp., 299 F.3d 1313, 1327 (Fed.Cir.2002); *see* Alloc, Inc. v. ITC, 342 F.3d 1361, 1377 (Fed.Cir.2003) ("a claim term will not carry its ordinary meaning if the intrinsic evidence shows that the patentee limited the scope of the claims").... Above all, the intrinsic evidence must show a clear and unmistakable intent to limit claim scope in order to overcome ordinary meaning and narrow a claim. Liebel-Flarsheim, 358 F.3d at 906.

Honeywell Int'l, Inc. v. ITT Indus., Inc., 330 F.Supp.2d 865, 867-77 (E.D.Mich.2004).FN8

FN8. The Court subsequently found the patent in Honeywell was not infringed, guided in large part by the Markman decision. Honeywell Int'l, Inc. v. ITT Indus., Inc., No. 02-73948, 2005 WL 5416765 (E.D.Mich. May 17, 2005) (unpublished). The Federal Circuit affirmed the Court's decision. Honeywell Int'l, Inc. v. ITT Indus., Inc., 452 F.3d 1312 (2006).

The Court went on to say:

It is a well established canon of claim construction that when a particular embodiment is described in the specification as the invention itself, and not just one way of utilizing it, the claims are not entitled to a scope broader than that embodiment. For instance, if the specification calls an embodiment "the invention" or "the present invention," it is appropriate to limit the claims to that embodiment.

Id. at 878-79 (citations omitted).

[10] Thus, a claim term must be given its ordinary meaning unless the patentee redefined the term in the specification or characterized the invention "in the intrinsic record using words or expressions of manifest exclusion or restriction, representing a clear disavowal of claim scope." *Teleflex, Inc. v. Ficosa N. Am.*, 299 F.3d 1313, 1327 (Fed.Cir.2002). With these principles in mind, the Court considers the identified claim terms.

IV. Analysis

A. Introduction

1. Specifications

The specifications of the three patents in suit do not clearly define any of the phrases or terms that Burnex has identified as ambiguous. Nor do the specifications use the identified phrases or terms in a way that would imply some meaning other than the ordinary ones, although at times a specification does shed light on which of multiple ordinary meanings is more appropriate to the context.

While most of the specification language references particular embodiments or figures "in accordance with the present invention," the specifications of all three patents in suit contain the following language pertaining to the indicated figures:

FIG. 3 *a* depicts a side view of the generally U-shaped fastener 20 of the current invention.... ['705 patent, col. 3, ll. 34-35; '638 patent, col. 4, ll. 1-2; '971 patent, col. 3, ll. 34-35]

....

FIGS. 6 through 8 are depictions of the U-shaped fastener 20 of the current invention with hidden components shown in phantom.... ['705 patent, col. 4, ll. 6-7; '638 patent, col. 4, ll. 39-41; '971 patent, col. 4, ll. 5-6]

....

FIG. 9 depicts the use of the U-shaped fastener 20 of the current invention.... ['705 patent, col. 4, ll. 10-11; '638 patent, col. 4, ll. 43-44; '971 patent, col. 4, ll. 9-10]

....

FIGS. 16 through 18 are depictions of the U-shaped fastener 120 of the current invention with hidden components shown in phantom.... ['705 patent, col. 5, ll. 34-36; '638 patent, col. 6, ll. 1-3; '971 patent, col. 5, ll. 34-36]

FIG. 19 depicts the use of the U-shaped fastener 120 of the current invention.... ['705 patent, col. 5, ll. 38-39; '638 patent, col. 6, ll. 5-6; '971 patent, col. 5, ll. 38-39]

The Court notes this language in order to make explicit for the record those sections of the specifications that may have some potential for limiting a claim. Neither party has based any of its proposed interpretations on this language. Moreover, each of the U-shaped fasteners 20 and 120 was previously introduced in each of the paradigm claims using "in accordance with" or "embodiment." '705 patent, col. 3, ll. 14-16, col. 4, ll. 37-40; '638 patent, col. 3, ll. 48-50, col. 5, ll. 3-6; '971 patent, col. 3, ll. 14-16, col. 4, ll. 36-39.

2. Prosecution Histories

As noted earlier, Burnex says that the prosecution histories play a key role in interpreting the ambiguous words and phrases of the paradigm claims. However, although Burnex spends several pages discussing the prosecution histories of the three patents in suit, it does not cite any of the histories in support of its interpretations for specific claim terms or phrases.

3. Additional Observations

A word about the parties' filings is in order at this point. First, as Newfrey rightly observes, when Burnex first identified ambiguous terms, rather than identifying separate terms, for the most part it identified entire phrases.

Second, the parties have failed to adhere precisely to the exact phrases Burnex first identified. For example, in the combined claim chart for Claim 20 of the '971 patent, two "ands" and one "wherein" are underlined that were not originally identified as ambiguous.

Further, both parties offer interpretations for terms that were not identified by Burnex originally and are not underlined in the combined claim chart. For example, in Claim 20 of the '971 patent, "said base portion"-never identified as ambiguous-is rendered as "the base" by Burnex and as "the base portion" by Newfrey.FN9

FN9. Interpreting "said" as "the" at least has the merit of juror-friendliness.

Moreover, in its Markman brief, Burnex fails to set out each term or phrase clearly with headings or some other device, but rather runs everything together in one discussion of each claim.

Finally, Burnex first uses the natural numerical order of the patents when identifying ambiguous terms, and Newfrey properly follows this order in its Markman brief. However, Burnex then uses a different order in its Markman brief. Burnex says it does this for purposes of discussing the prosecution history, as the application for the last-issued patent was actually filed first. The Court finds no value but only confusion in this ordering.

B. The '705 Patent: Claim 1 Terms

1.

"a generally straight portion"

[11] Newfrey references a dictionary definition and says the term means "for the most part straight portion." Newfrey says "generally" means "for the most part" in common parlance, but the definition it cites is not the first but the third entry in its dictionary reference. In oral argument, Newfrey asserted verbally, along with a sweep of a laser pen over a graphic, that "the generally straight portion goes from the base all the way up to the tip," referring to an entire abutting flange. No support for this assertion is to be found in the claim or the specification. The pertinent part of the claim language follows:

at least one abutting flange extending outwardly from each of the pair of side members, *each of the at least one abutting flange having a generally straight portion, a transition portion and an engaging portion, the generally straight portion coupling the at least one abutting flange to one of the side members near the insertion end of generally U-shaped fastener, the transition portion being coupled to the generally straight portion and being defined by an exterior convex surface, the engaging portion having an exterior concave surface immediately abutting the exterior convex surface of the transition portion and extending continuously from the transition portion, the exterior concave engaging surface having a radius between 3.5 millimeters and 6.0 millimeters and being adapted to engage an edge of the mounting aperture upon insertion therein to retain the generally U-shaped fastener in the mounting aperture.*

col. 6, ll. 25-41 (emphasis added). Claim 1 describes an abutting flange with three distinct portions: (1) a generally straight portion, (2) a transition portion, and (3) an engaging portion. The generally straight portion does not subsume the transition and engaging portions. To the contrary, the generally straight portion couples the flange to one of the side members of the fastener near the fastener's insertion end. The insertion end of the fastener is the place where "a pair of side members" are "coupled to each other by a curved base portion." col. 6, ll. 9-10. The transition portion is defined by an exterior convex surface and couples to the generally straight portion. The engaging portion has an exterior concave surface that immediately abuts the exterior convex surface of the transition portion.

Burnex says the term means "a portion that is straight but with some amount of deviation from exactly straight allowed." Burnex has support in the Federal Circuit's interpretation of the term "generally parallel" in *Anchor Wall Sys., Inc. v. Rockwood Retaining Walls, Inc.*, 340 F.3d 1298 (Fed.Cir.2003). Finding "generally parallel" to be a "mathematically imprecise term," the court said the term "envisions some amount of deviation from exactly parallel." *Id.* at 1310-11.

The interpretation of "generally straight" is analogous to that of "generally parallel," as both terms refer to the geometry of lines and solids. Moreover, Newfrey's proposed interpretation would admit a portion that runs straight for a majority of its measure but sharply deviates from straight for some lesser measure as with, for example, a check mark. This interpretation finds no support in the claim, the specification, or the prosecution history.

The Court adopts the following interpretation: "a portion that is straight but not necessarily precisely 180 degrees."

2.

"an exterior concave surface immediately abutting the exterior convex surface of the transition portion and extending continuously from the transition portion"

[12] Newfrey proposes the following interpretation: "an exterior concave surface *without delay bordering upon and extending without break* from the exterior convex surface of the transition portion" (both emphases added).

Burnex proposes the following interpretation: "an exterior concave surface that immediately abuts the exterior convex surface of the transition portion *without any intermediate surface therebetween*" (emphasis added).

The parties appear to agree that three terms are clear and concise, having their plain and ordinary meaning, and therefore require no interpretation: "exterior concave surface," "exterior convex surface," and "transition portion."

However, two terms require interpretation: "immediately abutting" and "extending continuously."

a. "immediately abutting"

Newfrey references a dictionary definition for "immediately" and says the term means "without delay." Newfrey also references a dictionary definition for "abutting" and says the term means "bordering upon."

Burnex says that "immediately abuts" means "without any intermediate surface therebetween." Newfrey puzzles in the combined chart that Burnex either fails to provide a construction for the claim term "extending continuously from the transition portion" or it is defining this term as "without any intermediate surface therebetween." Newfrey has reason to wonder. Based on Burnex's argument, its proposed interpretation appears to subsume both "immediately abuts" and "extending continuously":

Contrast the term "immediately abutting" and "extending continuously" of claim 1 of the '705 patent, to the term "substantially abutting" of claim 1 of the '638 patent. The modifiers, "immediately" and "continuously" denote exactitude; the modifier "substantially" connotes approximation. It follows logically that the claim phrase requires **the engaging portion have an exterior concave surface that immediately abuts the exterior convex surface of the transition portion without any intermediate surface therebetween.**

So, in the interpretation Burnex proposes for the larger term, it retains "immediately abut[ting]" along with "without any intermediate surface therebetween."

In its argument Newfrey proposes interpreting "immediately abutting" as "bordering upon without delay" but in the combined chart Newfrey presents, it also retains "immediately abutting."

Because both parties ultimately retain "immediately abutting," there is no need to interpret the term. The Court observes, however, that "delay" ordinarily implies time. If it were pushed to interpret "immediately" in the context of this invention for a jury, the Court would prefer "directly" or "without any intermediate surface therebetween." Both of these are ordinary dictionary definitions more fitting to the claim than "without delay."

b. "extending continuously"

As discussed above, Burnex appears to propose "without any intermediate surface therebetween" as the interpretation for "extending continuously." Newfrey proposes "extending without break," citing a dictionary reference for "continuous" that gives a third definition related to mathematics: "Of or relating to a line or curve that extends without a break or irregularity." In contrast, Burnex's proposed definition is more appropriate to "immediately," as discussed above, than to "continuously."

The Court adopts Newfrey's interpretation.

3.

"the exterior concave engaging surface having a radius between 3.5 millimeters and 6.0 millimeters"

The parties have agreed and the Court finds that the phrase requires no interpretation.

C. The '638 Patent: Claim 1 Terms

1.

"a generally straight portion"

The Court adopts the reasoning and interpretation of this phrase discussed for Claim 1 of the '705 patent under IV.A.I above: "a portion that is straight but not necessarily precisely 180 degrees."

2.

"the transition portion"

Newfrey says no interpretation is necessary for "the transition portion." Burnex proposes "a portion" but gives no reason for changing "the" to "a" and omitting "transition" from its interpretation.

The Court finds that no interpretation is necessary for "the transition portion."

3.

"being defined by an exterior convex surface"

[13] Newfrey cites a dictionary definition in proposing the following interpretation: "outlined by an exterior convex surface." Burnex proposes: "consisting of an exterior convex surface only." Burnex gives no authority or argument for its interpretation.

There is no reason to agree with Burnex that "defined by" means "consisting of ... only." On the one hand, "consisting of" is too broad for the context. As the specification states, "Generally, the abutting flanges 28 are *defined by* three portions. The first portion 36 is *defined by* an exterior concave engaging surface 50. The section portion 37, which acts as a transition to the third portion 38, is *defined by* a convex surface." Col. 3, ll. 60-65 (all emphases added). Figure 4 from the '638 patent, shown below, illustrates the relationship in conjunction with Figure 1 shown under II.A.1. above for the '705 patent. The use of "x [is][are] defined by y" in this context means that y gives form to x. This is entry 3 in the dictionary reference provided by Newfrey.

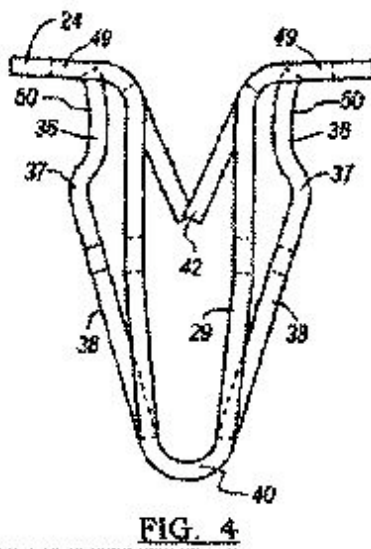

FIGURE 4

On the other hand, "consisting of ... only" is too narrow-and nonsensical. By definition, if the portion has an exterior surface, it must have an interior surface; otherwise, "exterior" would have no meaning.FN10 Therefore, it is not possible for the transition portion to consist of an exterior surface only.

FN10. In the context of the invention, the "exterior" concave surface of the abutting flange is oriented to the outside of the fastener.

Newfrey's proposed "outlined by" is too broad. Newfrey takes "outlined" from entry 2a of its dictionary reference: "To delineate the outline or form of: *gentle hills that were defined against the sky.*" Notice that in the example given by entry 2a, the preposition used is "against," not "by." The hills and the sky are independent, and the outline of the hills shows against the sky. By contrast, in the invention, the flanges and the portions are not independent; the first portion and the exterior concave engaging surface are not independent; the third portion and the convex surface are not independent. And, in particular, the transition portion and the exterior convex surface are not independent.

The language of the claim and the language in the specification do not support Newfrey's interpretation that the exterior convex surface merely delineates the outline or form of the transition portion. The convex surface is no mere outline. Rather, it actually gives form to the transition portion. That is, in this context, "being defined by" means "given form by." This squares with entry 3 in Newfrey's dictionary reference. Figure 4, above, illustrates at 37.

The Court interprets "being defined by an exterior convex surface" as "given form by an exterior convex surface."

4.

"an exterior concave surface substantially abutting the exterior convex surface of the transition portion"

In its brief, Newfrey proposes the following interpretation: "an exterior concave surface approximately

bordering upon the exterior convex portion of the transition portion." It cites the Federal Circuit for support of its assertion that "substantial" implies "approximate." *Playtex Products, Inc. v. Procter & Gamble Co.*, 400 F.3d 901, 907 (Fed.Cir.2005) ("substantially flattened surface"); *Liquid Dynamics Corp. v. Vaughan Co., Inc.*, 355 F.3d 1361, 1368-69 (Fed.Cir.2004) ("substantial helical"); *Cordis Corp. v. Medtronic AVE, Inc.*, 339 F.3d 1352, 1360 (Fed.Cir.2003) ("substantially uniform thickness").

However, in the combined claim chart, Newfrey proposes "an exterior concave surface substantially abutting the exterior convex surface of the transition portion," which is identical to the original claim language.

In its brief, Burnex agrees with Newfrey's position that "substantially" is language of approximation, citing *Epcon Gas Sys., Inc. v. Bauer Compressors, Inc.*, 279 F.3d 1022, 1031 (Fed.Cir.2002) ("substantially constant" vs. "substantially below"). Burnex proposes the following interpretation: "a portion FN11 having an exterior concave surface substantially abutting the exterior convex surface of the transition portion without a significant intermediate section therebetween." The only reason Burnex gives for its proposed addition of "without a significant intermediate section therebetween" is that "[t]he lack of an intermediate section between the concave and convex portions was the argued novelty of this claim and should not be erased via claim construction." Burnex cites nothing from the record to support this assertion.

FN11. Burnex does not explain why it proposes to interpret "the engaging portion" as "a portion" and Burnex never identified "the engaging portion" as ambiguous. Therefore, the Court will disregard this part of Burnex's proposed interpretation.

Because both parties retain "substantially abutting" in their proposed interpretations in the combined claim chart, the Court sees no reason to interpret this phrase. If pressed to adopt "approximately" as the interpretation for "substantially," however, the Court would have some hesitation over doing so in this context. In all the examples cited by Newfrey, "substantial" does mean "approximate." But as the Federal Circuit points out in *Epcon Gas*, 279 F.3d at 1030-31, although "substantially constant" means "approximately constant," nevertheless "substantially below" means "to a considerable degree below." Context matters. As Newfrey points out, "abut" means "border upon." To "approximately border upon" makes little sense. "Substantially abutting," then, would mean something like "abutting at a considerable number of end points."

D. The '971 Patent: Claim 20 Terms

1.

"a pair of elastic abutting flanges ... outwardly extending ... into an aperture in each said top flange member"

[14] Newfrey proposes the following interpretation: "a pair of elastic abutting flanges ... extending outwardly ... into an aperture in each top flange." Newfrey says that "said" is less juror-friendly than "the."

Burnex proposes: "each of the elastic abutting side flanges extends outwardly from the base and into an aperture in its respective top flange." Burnex offers no reason for eliminating "a pair" or for replacing "each" with "its respective." Both parties transpose "outwardly" with "extend[ing]" but offer no reason for doing so.

The Court adopts Newfrey's interpretation.

2.

"a first pair of spaced apart finger members integrally formed with each said top flange member; and"

[15] Newfrey proposes the following interpretation: "a first pair of spaced apart fingers integrally formed with each top flange." Newfrey says that "top flange member" should be shortened to "top flange" because "member" adds no further definition.

Burnex proposes: "two spaced apart finger members, each of which is integrally formed with one of the two top flange members." Burnex gives no reason to interpret "a first pair of" as "two," or "each said" as "one of the two."

The Court adopts Newfrey's interpretation.

3.

"a second pair of spaced apart finger members integrally formed with each said side wall, and"

[16] Newfrey proposes the following interpretation: "a second pair of spaced apart fingers integrally formed with each side wall."

Burnex proposes: "two spaced apart finger members each of which is integrally formed with one of the two side walls." Burnex offers no reasoning.

The Court adopts Newfrey's interpretation.

4.

"wherein the base portion and opposed sidewalls define a centerline and"

Both parties propose the following interpretation: "wherein the base portion and opposed side walls define a centerline." The only differences between the original and the parties' interpretation are "sidewalls" becomes two words and "wherein" is dropped for the jury. The Court adopts the parties' interpretation.

5.

"wherein said finger members cross said centerline, and"

[17] Newfrey proposes the following interpretation: "the first and second pair of fingers cross the centerline."

Burnex proposes: "each of the 'second pair of spaced apart finger members' recited in the beginning of the same paragraph must cross the centerline." Burnex is rightly concerned with the ambiguity that "said finger members" yields. The claim's paragraph structure in the published patent, as reproduced in relevant part below, signifies that "said finger members" here refers to the second pair of finger members:

a first pair of spaced apart finger members integrally formed with each said top flange member; and

a second pair of spaced apart finger members integrally formed with each said side wall, and wherein the base portion and opposed sidewalls define a centerline and wherein said finger members cross said centerline, and

wherein said pairs of finger members inwardly extend into said body of the fastener and are configured to grippingly engage the coupling flange.

col. 8, ll. 4-13. According to the paragraph structure, "wherein the base portion and opposed sidewalls define a centerline" and "wherein said finger members cross said centerline" modify only "a second pair of spaced apart finger members integrally formed with each said side wall." Nothing in the specification contradicts this interpretation. The prosecution history supports this interpretation, as the paragraph structure in the filed amended claim 22 was identical to that of the published claim 20 and it is therefore clear that the published structure is not a result of typographical error at the PTO. The rules support this interpretation. "Where a claim sets forth a plurality of elements or steps, each element or step of the claim should be separated by a line indentation." 37 C.F.R. s. 1.75(i). It would have been a simple matter to indent the disputed phrase separately, as with the final paragraph of the claim, if that is what was intended.

Newfrey cites nothing in the specification or prosecution history to support its interpretation. In its brief, Newfrey does present Figure 20A of the '971 patent, shown below, at the beginning of the discussion of Claim 20 but does not refer to any figures when discussing the disputed phrase.

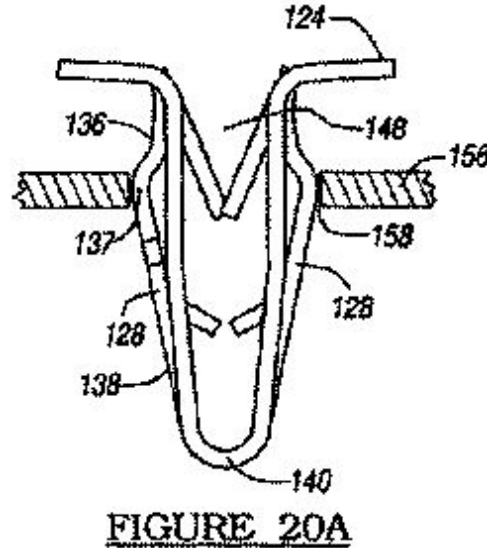

FIGURE 20A

FIGURE 20A

In oral argument, Newfrey, referring to Figure 15 of the '971 patent, shown above under II.B.2. for the '638 patent, FN12 said, "[T]he figure clearly shows and the figures describe crossing at the top for the first pair." Newfrey is correct that Figure 15 shows a first pair crossing the centerline. Figure 20A does also. But the specification does not describe this crossing verbally, nor is there any explicit link made between Figure 15 or 20A and Claim 20. FN13 Further, neither Figure 15 nor Figure 20A purports to depict the invention itself. According to the specification, each of these two figures depicts a view of "the U-shaped fastener 120." Col. 5, ll. 3, 45. The "generally U-shaped fastener 120" represents a "second embodiment of the present [current] invention." Col. 4, ll. 36-38, 56-58.

FN12. Figure 15 is the same for all three patents in suit.

FN13. The Court notes that both figures depict a second pair that clearly does *not* cross the centerline. As Newfrey relies entirely on these figures for support of its interpretation, it is a mystery as to why it proposes "the first and second pair of fingers cross the centerline."

The Court finds that the interpretation of the phrase is: "the second pair of spaced apart fingers crosses the centerline."

6.

"wherein said pairs of finger members inwardly extend into said body of the fastener and are configured to grippingly engage the coupling flange"

[18] Newfrey proposes the following interpretation: "the first and second pair of fingers extend inwardly into the body of the fastener and are configured to engage the coupling flange by gripping it." Newfrey gives no reason for transposing "inwardly" with "extend[ing]."

Burnex proposes: "all four finger members extend inwardly into the body of the fastener and are configured to engage the coupling flange by gripping it." Burnex gives no reason for limiting the finger members to four, deleting the "pair" notation, or transposing "inwardly" with "extend."

Although "to engage ... by gripping" is narrower than "to grippingly engage," Newfrey has agreed to this interpretation, which does have the potential benefit of being more understandable to a jury. The paragraph structure in the published patent supports interpreting "said pairs" as "said first and second pair," although the plural form of the original would seem to make this unnecessary. Nevertheless, as the parties seem to agree that some disambiguation is needed, and as the parties both transpose "inwardly" and "extend," the Court adopts the following interpretation: "the first and second pair of fingers extend inwardly into the body of the fastener and are configured to engage the coupling flange by gripping it."

V. Conclusion

"Patent claim interpretation ('construction') is the process or result of determining the meaning of patent claims. This is not only central but often outcome-determinative to many patent disputes." Edward D. Manzo, *Introduction to Claim Construction in the Federal Circuit* at xi. (Edward D. Manzo ed., 2008). In this Markman process, the Court has determined the metes and bounds of Claim 1 of the '705 patent, Claim 1 of the '638 patent, and Claim 20 of the '971 patent so that the disputed words, properly interpreted, have captured the inventions of the patents and given notice to the world as to what they cover.

As indicated at the beginning of this decision, the respective positions of the parties are displayed in the claim charts attached as Exhibits A, B, and C. The exhibits also depict the constructions by the Court that govern further proceedings in this case. Nevertheless, these conclusions remain open to change as the case unfolds in the validity and infringement phases.

SO ORDERED.

E.D.Mich., 2008.
Newfrey, LLC v. Burnex Corp.

Produced by Sans Paper, LLC.