

United States District Court,
E.D. Texas, Marshall Division.

COOPERVISION, INC,
Plaintiff.

v.

CIBA VISION CORPORATION,
Defendant.

Civil Action Nos. 2:06-CV-149, 9:06-CV-260

July 16, 2007.

Adam S. Hoffman, Amir A. Naini, David I. Gindler, Douglas Nejaime, Jason G. Sheasby, Jonathan Steinsapir, Morgan Chu, Raj Sardesai, Irell & Manella, LLP, Los Angeles, CA, Ben Yorks, Michelle Armond, Irell & Manella, Newport Beach, CA, Clayton Edward Dark, Jr., Attorney at Law, Lufkin, TX, J. Thad Heartfield, The Heartfield Law Firm, Beaumont, TX, for Plaintiff.

Virgil Bryan Medlock, Jr., Catherine Isabelle Casey Rajwani, Debera Denise Wells, Feras Alkasab, Michael David Hatcher, Sidley Austin, Dallas, TX, Charles W. Goehringer, Jr., Lawrence Louis Germer, Germer Gertz, L.L.P., Beaumont, TX, Stephanie P. Koh, Thomas D. Rein, Sidley Austin, Chicago, IL, for Defendant.

**MEMORANDUM OPINION AND ORDER CONSTRUING CLAIM TERMS OF UNITED STATES
PATENT NOS. 6,431,706; 6,923,538; 6,467,903; 6,857,740; 6,971,746; 7,133,174; and 7,134,753 FN1**

FN1. This Order governs in the event of any conflict between the Order and the Court's preliminary analysis at the hearing. The record including the answers of the parties' counsel and experts to questions from the court, may be helpful in understanding the parties' arguments and the reasons for the conclusions set out herein.

EARL S. HINES, United States Magistrate Judge.

Plaintiff CooperVision, Inc. ("CooperVision") filed these actions against Defendant CIBA Vision Corporation ("CIBA") claiming infringement of United States Patent Nos. 6,431,706 and 6,923,538 (collectively, "the Edge Design patents") and of United States Patent Nos. 6,467,903; 6,857,740; 6,971,746; 7,133,174; and 7,134,753 (collectively, "the Toric patents"). The court conducted a *Markman* hearing to assist the court in interpreting the meaning of the claim terms in dispute. Having carefully considered the patent, the prosecution history, the parties' briefs, and the arguments of counsel, the court now makes the following findings, and construes the disputed claim terms.

I. CLAIM CONSTRUCTION STANDARD OF REVIEW

Claim construction is a matter of law. *Markman v. Westview Instruments, Inc.*, 517 U.S. 370, 116 S.Ct. 1384, 134 L.Ed.2d 577 (1996) ("*Markman II*"). "The duty of the trial judge is to determine the meaning of the claims at issue, and to instruct the jury accordingly." *Exxon Chem. Patents, Inc. v. Lubrizoil Corp.*, 64 F.3d 1553, 1555 (Fed.Cir.1995) (citations omitted).

" '[T]he claims of the patent define the invention to which the patentee is entitled the right to exclude.' " *Phillips v. AWH Corp.*, 415 F.3d 1303, 1312 (Fed.Cir.2005) (*en banc*) (citation omitted). "Because the patentee is required to 'define precisely what his invention is,' it is 'unjust to the public, as well as an evasion of the law, to construe it in a manner different from the plain import of its terms.' " *Phillips*, 415 F.3d at 1312 (quoting *White v. Dunbar*, 119 U.S. 47, 52, 7 S.Ct. 72, 30 L.Ed. 303 (1886)).

The words of a claim are generally given their ordinary and customary meaning. *Phillips* 415 F.3d at 1312. The "ordinary and customary meaning of a claim term is the meaning that the term would have to a person of ordinary skill in the art in question at the time of the invention." *Id.* at 1313. Analyzing "how a person of ordinary skill in the art understands a claim term" is the starting point of a proper claim construction. FN2 *Id.*

FN2. Based on the patent and its cited references, the tutorials, and the representations of the parties at the hearing, the court finds that "one of ordinary skill in the art" for the rounded edge patents is someone with either 1) a Doctors degree in Optometry, including 2-3 years gaining knowledge of contact lens manufacturing techniques; or 2) a bachelor's degree in an area such as chemistry, physics or an engineering discipline with approximately 1-5 years of experience designing contact lenses, knowledge of contact lens manufacturing techniques and knowledge of clinical evaluation of contact lens performance. For the toric patents, "one of ordinary skill in the art" is someone with either 1) a Doctors degree in Optometry, including 2-3 years gaining knowledge of contact lens manufacturing techniques; or 2) a bachelor's degree in an area such as chemistry, physics or an engineering discipline with approximately 5 years of experience designing contact lenses.

A "person of ordinary skill in the art is deemed to read the claim term not only in context of the particular claim in which the disputed term appears, but in the context of the entire patent, including the specification." *Phillips*, 415 F.3d at 1313. Where a claim term has a particular meaning in the field of art, the court must examine those sources available to the public to show what a person skilled in the art would have understood disputed claim language to mean. *Id.* at 1414. Those sources "include 'words of the claims themselves, the remainder of the specification, the prosecution history, and extrinsic evidence concerning relevant scientific principles, the meaning of technical terms, and the state of the art.' " *Id.* (citation omitted).

"[T]he ordinary meaning of claim language as understood by a person of skill in the art may be readily apparent even to lay judges, and claim construction in such cases involves little more than the application of the widely accepted meaning of commonly understood words." *Phillips*, 415 F.3d at 1314. In these instances, a general purpose dictionary may be helpful. *Id.*

However, the Court emphasized the importance of the specification. "[T]he specification 'is always highly relevant to the claim construction analysis. Usually it is dispositive; it is the single best guide to the meaning of a disputed term.' " *Phillips*, 415 F.3d at 1315 (quoting *Vitronics Corp. v. Conceptronic, Inc.*, 90 F.3d 1576, 1582 (Fed.Cir.1996)). A court is authorized to review extrinsic evidence, such as dictionaries, inventor

testimony, and learned treatises. Phillips, 415 F.3d at 1317. But their use should be limited to edification purposes. Id. at 1319.

The intrinsic evidence, that is, the patent specification, and, if in evidence, the prosecution history, may clarify whether the patentee clearly intended a meaning different from the ordinary meaning, or clearly disavowed the ordinary meaning in favor of some special meaning. *See Markman v. Westview Instruments, Inc.*, 52 F.3d 967, 979-80 (Fed.Cir.1995). Claim terms take on their ordinary and accustomed meanings unless the patentee demonstrated "clear intent" to deviate from the ordinary and accustomed meaning of a claim term by redefining the term in the patent specification. *Johnson Worldwide Assoc., Inc. v. Zebco Corp.*, 175 F.3d 985, 990 (Fed.Cir.1999).

The "'ordinary meaning' of a claim term is its meaning to the ordinary artisan after reading the entire patent." Phillips, 415 F.3d at 1321. However, the patentee may deviate from the plain and ordinary meaning by characterizing the invention in the prosecution history using words or expressions of manifest exclusion or restriction, representing a "clear disavowal" of claim scope. *Teleflex, Inc. v. Ficosa N. Am. Corp.*, 299 F.3d 1313, 1327 (Fed.Cir.2002). It is clear that if the patentee clearly intended to be its own lexicographer, the "inventor's lexicography governs." Phillips, 415 F.3d at 1316.

II. PATENT BACKGROUND AND TECHNOLOGY

The first family of patents, the "Edge Design" patents, share the same specification as each other and relate to edge designs for cast molded contact lenses. The second family of patents, the "Toric" patents, share the same specification as each other and relate to surface topography designs for toric lenses designed to treat astigmatism. Therefore, just as the parties have done in their briefs, references to the specification of the '706 patent are used interchangeably for each of the Edge Design patents and references to the specification of the '903 patent are used interchangeably for each of the Toric patents.

A. The Edge Design Patents

The Edge Design patents relate to methods and tools for producing contact lenses with a substantially smooth, rounded edge profile without the need for post-processing steps. Contact lenses are made using a tooling insert or tool, having a surface generally corresponding to a desired contact lens surface and a convex curve along an outer or peripheral radius, to form a first mold section which defines a negative impression of a surface of the final lens product. In other words, the surface of the tool generally corresponds, preferably, to a posterior face and edge of the contact lens to be formed. A second mold section may be made in a conventional manner and preferably defines a negative impression of the anterior surfaces (face and edge) of the contact lens being produced. The two mold sections are assembled to produce a final contact lens. The mold sections typically are used only once for casting an individual lens, while the injection molding tools are used to make hundreds of mold sections.

B. The Toric Patents

The Toric patents involve a contact lens with an improved thickness and rotational stabilization structure designed to maximize eyelid interaction and reduce the variability of lens orientation between individuals in lenses that are non-axi-symmetric, such as toric or multifocal lenses. More specifically, the invented contact lenses have "ballast," i.e., elevated surfaces that interact with the blinking action of the eyelids to re-orient the lens about a vertical meridian. The contact lens may have uniform or iso-thickness in the horizontal cross-sections to reduce the torque imparted on the lens during blinking. Additionally, the thickness of the

lens may decrease within the peripheral zone to provide more comfort to the lens-wearer.

III. CLAIM CONSTRUCTION

A. *The Edge Design Patents*

1. "[B]ack surface tool including ... a convexly curved second surface portion circumscribing the first surface portion." Used in '706 patent, claim 1.

"[T]he surface of the tool including ... a second surface portion defining a convex curved outer peripheral edge surface of the insert." Used in '706 patent, claim 15.

CooperVision argues that "a 'convex[ly] curved surface' is an outward facing curved surface containing a continuous curve, or a series of flats, or a combination of one or more curves and one or more flats. A 'second surface portion circumscribing the first surface portion' is the outer peripheral edge surface." CIBA advances a competing construction of "a second surface portion that circumscribes the first surface portion and the entire second surface portion is curved outward like the exterior of a sphere so as to produce a contact lens with a rounded edge."

The parties now agree that the "convex curve" of the invention may be created by a continuous curve, or a series of flats, or a combination of curves and flats. At the hearing, the parties clarified that the remaining points of dispute are whether: 1) the flats, if any, must be small; 2) the convexly curved second surface portion must extend to the end of the insert tool; and 3) the contact lens produced must have a rounded edge. These points are now considered *seriatim*.

a. "Flats"

The parties apparently agree that flats mean straight segments. Turning first to claims language, claim 1 of the '706 patent recites that the back surface tool disclosed includes a "convexly curved second surface portion." Similarly, claim 15 recites: "a second surface portion defining a convexly curved outer peripheral surface." Dependant claims 17 and 18 indicate that the convex curve may also be created by a series of flats approximating a convex curve or a combination of flats and convex curves.

Looking next at the specification, the patent discloses that "[t]he second surface portion may be defined by a continuous curve Alternatively, the second surface portion may be defined by a series of *small* flats, or a combination of *small* flats and curves, *which approximate a convexly curved surface*." '706 patent, col. 3, ll. 43-49 (emphasis added). The invention thus permits the use of small flats to make up the curved convex shaping.

CooperVision argues that the flats may be any size, including large flats or straight segments. However, when reading the claims in light of the specification, it is clear that if flats are present, then they must be either small or very short. *See* '706 patent, col. 7, ll. 1-4 ("very short flats would closely simulate continuously curved convex shaping"); '706 patent, col. 3, ll. 43-49.

CooperVision opposes this interpretation, arguing that the term "small" would render the claim indefinite. A patent specification must "conclude with one or more claims particularly pointing out and distinctly claiming the subject matter which the applicant regards as his invention." 35 U.S.C. s. 112, para. 2. The purpose of the definiteness requirement is to "ensure that the claims delineate the scope of the invention

using language that adequately notifies the public of the patentee's right to exclude. *Datamize*, 417 F.3d 1342, 1347 (Fed.Cir.2005). Claims are considered indefinite when they are "not amenable to construction or are insolubly ambiguous.... Thus, the definiteness of claim terms depends on whether those terms can be given any reasonable meaning." *Id.* To make a determination of indefiniteness, "general principles of claim construction apply." *Id.* at 1348.

The specification makes clear that the flats must be small enough to define a continuous curve with a radius of curvature of about 0.05 mm. '706 patent, col. 3, ll. 45-49. Because the flats may be combined with curves to create the convexly curved outer peripheral edge surface, it is not inappropriate to describe the flats as "small," as opposed to a precise numerical measurement. Akin to the term "large," a person having ordinary skill in the art would know how small the flats must be to maintain a 0.05 mm radius of curvature. *See, e.g., O'Hara Mfg. Ltd. v. Eli Lilly & Co.*, 1986 WL 8391 (N.D.Ill., July 21, 1986) (holding that the word "large" is not indefinite even if it does not specify an exact amount.)

CIBA does not dispute that the convexly curved surface can be formed by a series of one or more curves, by a combination of curves, by a combination of curves and flats or by a series of small flats that approximate a continuous curve. However, CIBA's proposed construction sounds as though the second surface portion must have a single radius of curvature or be a section from a perfect circle.

b. Extent of Convexly Curved Surface

CIBA argues that the convexly curved second surface portion must extend to the end of the entire back surface tool. Figure 8 shows that the tool has an extended flat portion which does not affect the configuration of any part of the lens. When describing the convexly curved second surface portion, the claim and specification clearly refer to the part of the tool that affects the shape of the lens. *See* '706, col. 3, ll. 32-45.

c. Rounded Edge?

CIBA's construction includes a separate requirement that the back surface tool "produce a contact lens with a rounded edge." Formation of a "contact lens member" appears in the last phrase of claim 1. CIBA proposes to add the term to the first phrase, thus making the last phrase superfluous. "A claim construction that gives meaning to all the terms of the claim is preferred over one that does not do so." *See Merck & Co. v. Teva Pharms. USA, Inc.*, 395 F.3d 1364, 1372 (Fed.Cir.2005). Accordingly, there is no basis to add the phrase, "produce a contact lens ..." to the definition of this claim term. Similarly, Claim 15 describes the surface tool but makes no reference to the shape of the contact lens. Again, there is no basis to include the phrase "... with a rounded edge" to the definition of this claim term.

d. Definition

The court defines these disputed terms as follows:

"[B]ack surface tool including a first surface portion in the general shape of a posterior face of a contact lens and a convexly curved second surface portion circumscribing the first surface portion" and "the surface of the tool including a first surface portion in the general shape of a posterior face of a contact lens and a second surface portion defining a convex curved outer peripheral edge surface of the insert" means: **Back surface tool including a first surface portion in the general shape of a posterior face of a contact lens and a second surface portion defined by an the outer peripheral edge surface of the insert. The second**

surface portion is an outward facing curved surface created from a continuous curve, a series of small flats (i.e., straight segments) that approximate a continuous curve, or a combination of curves and small flats that approximate a continuous curve.

2. "[F]orming a contact lens member in the lens shaped cavity of the assembled mold sections." Used in Claim 1 of '706 patent.

"A tool useful in making a mold section for cast molding a contact lens." Used in Claim 15 of the '706 patent.

CooperVision argues that these phrases do not require construction. CIBA construes "forming a contact lens member in the lens shaped cavity of the assembled mold sections" to mean "forming a contact lens member *with a rounded edge* in the lens shaped cavity of the assembled mold sections" and "a tool useful in making a mold section for cast molding a contact lens" to mean "a tool useful in making a mold section for cast molding a contact lens *with a rounded edge*." (emphasis added). CIBA adds only the words, "with a rounded edge" to each of the terms.

CIBA contends that the term "contact lens member," as used in the Edge Design Patents, requires the presence of a "rounded edge" and that both the specification and prosecution history suggest that the term "contact lens member" requires such an edge. For that reason, CIBA argues, claim 1 and claim 15 produce a contact lens with a rounded edge.

Claim terms generally are given the meaning those terms would have to a person of ordinary skill in the art. *Phillips v. AWH Corp.*, 415 F.3d 1303, 1313 (Fed.Cir.2005). The ordinary meaning of the term "contact lens member" does not require the presence of a rounded edge. The asserted claims can be assigned a narrower scope only if there is some indication in the patent or prosecution history that the term contact lens member was meant to have a more restrictive meaning as used in the patent, or a broader meaning was disclaimed during prosecution. *See Phillips*, 415 F.3d at 1316; *Honeywell Int'l, Inc. v. ITT Indus., Inc.*, 452 F.3d 1312, 1319-20 (Fed.Cir.2006). CooperVision's counsel granted in oral argument that when the back surface mold insert tool is used correctly, the resulting mold will produce a rounded edge lens. Tr. at p. 18. Moreover, the preferred embodiment, i.e., the method that creates the most comfortable contact lenses, will have a substantially smooth, rounded edge. *See '706 patent*, col. 7, ll. 40-42. But that is not required by the claim language.

The strongest indication that the term "contact lens member," as used in claim 1 and claim 15, was not meant to include a "rounded edge" limitation can be found by comparing independent claim 1 and dependent claim 2. Claim 1 recites the formation of a "contact lens member" but does not expressly require a "rounded edge." Claim 2 recites: "The method of claim 1 wherein the contact lens member formed has a rounded edge." It does not add any additional limitation other than the limitation of a "rounded edge."

Given that claim 2 adds the "rounded edge" limitation to claim 1, the doctrine of claim differentiation supports the inference that claim 1 encompasses a contact lens without the rounded edge. Otherwise, claim 2 would add nothing to claim 1, and the two would cover identical subject matter. *See Curtiss-Wright Flow Control Corp. v. Velan, Inc.*, 438 F.3d 1374,1380 (Fed.Cir.2006) (holding that the presence of a dependent claim that adds a particular limitation gives rise to a presumption that the limitation in question is not present in the independent claim).

CIBA points to various features of the patent and the prosecution history in support of its argument that one of skill in the art would necessarily conclude that only contact lenses with a rounded edge are within the scope of claim 1 and claim 15 of the '706 patent. CIBA first contends that such a limitation is evident from the claim language requiring that the back surface tool be capable of forming "a contact lens having the desired rounded edge without the need for post formation processing steps." '706 patent, col. 2, ll. 50-55. Because the specification describes a contact lens with a rounded edge, and because the specification does not disclose any other way to avoid a pointed or chiseled edge profile, CIBA argues that a person of skill in the art would understand that a contact lens created by the back surface tool must have a rounded edge.

A patent that describes only a single embodiment is not necessarily limited to that embodiment. *Liebel-Flarsheim v. Medrad, Inc.*, 358 F.3d 898, 906 (Fed.Cir.2004). "Even where a patent describes only a single embodiment, claims will not be read restrictively unless the patentee has demonstrated a clear intention to limit the claim scope" *Innova/Pure Water, Inc. v. Safari Water Filtration Sys.*, 381 F.3d 1111, 1117 (Fed.Cir.2004). While an assertion by the patentee that a contact lens with a rounded edge is the only invention that can be created by a back surface tool would evidence an intention to narrow the scope of the independent claims, the '706 patent contains no such assertion.

In fact, the specification of the '706 patent contains passages expressly differentiating a contact lens from a contact lens with a rounded edge. In "Summary of the Invention," the specification states: "The demolded contact lens member may be the final contact lens. However, the demolded contact lens member may be hydrated to form the final contact lens with a rounded edge surface." '706 patent, col. 3, ll. 4-7. When the first and second mold sections are assembled together, either a "rounded edge contact lens *or* contact lens member in accordance with the present invention" may be formed. '706 patent, col. 3, ll. 64-65 (emphasis added). *See also* '706 patent, col. 3, ll. 52-53 ("*preferably*, a contact lens with a rounded edge surface, is provided"); '706 patent, col. 1, l. 7. Finally, the specification states:

Although there has been hereinabove described specific methods of manufacturing a rounded edge contact lens having a rounded peripheral edge surface or form, in accordance with the present invention, ... it should be appreciated that the invention is not limited thereto. '706 patent, col. 7, l. 64-col. 8, l. 2.

CIBA relies on dependent claim 4 in support of its argument that the method steps of claim 1 create a contact lens with a rounded edge. CIBA argues that the rounded edge in claim 4 does not come from demolding or hydration, and so dependent claim 4 makes clear that the method steps of claim 1 are what produce a contact lens with a rounded edge.

Claim 4 specifically calls for a "contact lens having a rounded edge" after the lens is demolded and hydrated. It is true that in a preferred embodiment, "[p]ost-formation processing such as demolding, hydration ... does not alter [the] rounded edge surface configuration." '706 patent, col. 3, ll. 12-15. However, hydration "may to some extent change the finished lens manufactured" to become much more rounded or less clearly defined. *See* '706 patent, col. 7, ll. 51-55. A "much more rounded or less clearly defined edge surface" may also be achieved by varying the angle of intersection of the two mold halves to 140 degrees. '706 patent, col. 8, ll. 40-42; *see also* Figure 8. Accordingly, neither the claim language nor the specification supports the narrowing construction that CIBA proposes.

The court, therefore, adopts CooperVision's position, and will not construe these phrases.

3. "[C]ontact lens having a rounded edge." Used in '706 patent, claim 4.

CooperVision contends that the term "contact lens having a rounded edge" means "a contact lens having a *posterior* surface in a general shape of an *insert tool* that includes a first *posterior* surface portion and a convexly curved second *posterior* surface portion that circum-scribes the first *posterior* surface portion." (All italics added.) CIBA, on the other hand, proposes a construction of "an edge that is shaped like a portion of a circle in which every part of the surface or the circumference is equidistant from a center point." CooperVision's proposed construction refers exclusively to the posterior lens surface edge and the tool that shapes the back section of the mold used to create the lens. CIBA's proposed definition contains no reference to the mold tool and does not distinguish between anterior and posterior edge surfaces.

CooperVision's interpretation has initial appeal. When considered in overall context, the *raison d'etre* or core element of the edge design patents is a *back surface* mold insert tool with a convexly curved outer peripheral edge. The tool produces the *back section* of a mold which eventually forms a lens with a convexly curved outer peripheral edge on its *back* or posterior surface. Common sense suggests that the rounded edge of the invention refers to the convexly curved outer peripheral edge of the posterior surface of the lens.

This proposed construction finds some support in certain language in the patents. Claim 4 states: "*The method of claim 3* which further comprises demolding the contact lens member and hydrating the contact lens member to form a hydrogel contact lens having a rounded edge." '706 patent, col. 8, ll. 31-34 (italics added). Claim 3 refers the reader to claim 1, which provides that the contact lens product is produced with a *back surface tool*. The court must look at the claim language first, and ascribe the plain and ordinary meaning to the phrase. *Hockerson-Halberstadt*, 222 F.3d 951, 955 (Fed.Cir.2000).

Second, the specification explains in some instances that "to form the rounded edge contact lens, the back surface tool having a convex curve along the outer radius thereof" is used to create a back surface mold, which is then assembled with another mold half to form a lens. '706 patent, col. 2, ll. 55-60. Elsewhere, the specification defines a lens with a rounded edge solely with reference to its back surface tool:

[T]he convex curve of the tool, when used to form a back surface mold section, provides a contact lens having the desired rounded edge form '706 patent, col. 2, ll. 31-54.

To form the rounded edge surface of the final lens product, the surface of the [back surface] tool includes ... a second surface portion defining a convex curved outer peripheral edge surface '706 patent, col. 3, ll. 40-45.

This language suggests that a contact lens with a rounded edge is a contact lens formed from a back surface tool with a convexly curved peripheral edge surface.

Despite its initial appeal, however, CooperVision's proposed construction does not fully survive further analysis. First, there is no evidence in the claim language itself supporting CooperVision's proposed limitation of a certain insert tool. The claim simply states that the contact lens is demolded and hydrated to form a hydrogel "contact lens having a rounded edge." '706 patent, col. 2, ll. 21-23; col. 8, ll. 31-34. This straightforward terminology of the invention and the understandable claim language give that meaning to this term. *See Phillips*, 415 F.3d at 1314 ("In some cases, the ordinary meaning of claim language as understood by a person of skill in the art may be readily apparent even to lay judges, and claim construction in such cases involves little more than the application of the widely accepted meaning of commonly

understood words"). "Contact lens with a rounded edge" means what it says, i.e., substantially smooth. '706 patent, col. 2, ll. 21-22; '706 patent, col. 5, ll. 30-32; '706 patent, col. 7, ll. 55-57. No claim language implies a departure from that meaning.

Similarly, the specification does not compel the court to deviate from the ordinary and customary meaning by importing added dimensions to the term. The specification consistently refers to an embodiment of the contact lens as having a "rounded edge." '706 patent, col. 3, ll. 51-52. However, nowhere does the patentee disclaim or disavow any other tool that can be used to form the rounded edge surface. Rather, when mentioning formation of a rounded edge lens, the specification states only that the tool is "preferably, a back surface tool," suggesting that the back surface tool, while preferred, is not the only tool that will create a rounded edge. '706 patent, col. 3, ll. 32-33. Simply put, when the specifications allude to "contact lens with a rounded edge," they do not reference the back surface tool in most instances.

Finally, and most importantly, even if a back surface tool is necessary to create a "contact lens with a rounded edge," it is improper to construe the claim term with such a tool when the tool is absent from the claim language. *See Phillips*, 415 F.3d at 1323 ("although the specification often describes very specific embodiments of the invention, [the Federal Circuit has] repeatedly warned against confining the claims to those embodiments In particular, [the Federal Circuit has] expressly rejected the contention that if a patent describes only a single embodiment, the claims of the patent must be construed as being limited to that embodiment").

Turning to the competing proposal, CIBA argues that the ordinary meaning of "round" is "having every part of the surface or circumference equidistant from the center." CIBA's Claim Construction Brief, p. 4. CIBA wholly relies on the definition in the Merriam-Webster's Collegiate Dictionary and The American Heritage Dictionary of the English Language. MERRIAM-WEBSTER'S COLLEGIATE DICTIONARY (10th ed., 1999); THE AMERICAN HERITAGE DICTIONARY OF THE ENGLISH LANGUAGE (4th ed., 2000). Dictionaries may be helpful but are "less significant than the intrinsic record in determining the legally operative meaning of claim language." *MBO Laboratories, Inc. v. Becton, Dickinson & Co.*, 474 F.3d 1323, 1329 (Fed.Cir.2007).

CIBA's proposal requires a "rounded edge" lens to be one in which the edge must have a circular, or approximately circular shape. The specification, however, contemplates that lenses covered by the invention can have different levels of peripheral edge roundness. *See* '706 patent, col. 7, ll. 34-47 (increasing the size of the angle at which the front and back surface molds meet, the "angle of interface," can increase the roundness of a lens edge). Accordingly, CIBA's proposed construction also is deficient.

Ultimately, the court partially adopts each side's construction. CooperVision correctly advocates that this claim term refers to the posterior surface edge of a contact lens, and that dictionary definitions do not trump the intrinsic record. CIBA correctly argues that this claim does not explicitly ascribe a specific tool that must be used to form the rounded edge surface.

Having considered all relevant factors, the court finds that:

"[C]ontact lens having a rounded edge" means: **contact lens whose posterior surface has a substantially smooth, curved outer peripheral edge.**

4. "A lens body comprising a hydrogel material and having an anterior face, a posterior face, and a

rounded outer peripheral edge surface." Used in '706 patent, claim 13.

"A lens body comprising a hydrophilic silicone-containing material having an anterior face, a posterior face having a rounded outer peripheral edge surface ..." '538 patent, claim 1 and 7.

CooperVision defines these terms to mean "a contact lens with an anterior face and a posterior face having a surface in a general shape of an insert tool that includes a first surface portion and a convexly curved peripheral edge surface." CIBA's proposed construction is the same as its definition for "contact lens having a rounded edge," namely "an edge that is shaped like a portion of a circle in which every part of the surface or the circumference is equidistant from a center point." These definitions substantially reproduce the dispute regarding the meaning of "contact lens having a rounded edge," discussed above, in claim 4 of the '706 patent.

Claim 13 of the '706 patent contains different language from claims 1 and 7 of the '538 patent. It describes a lens with an "anterior face, a posterior face, *and* a rounded peripheral edge surface extending from the anterior face to the posterior face." Claims 1 and 7 of the '538 patent recite only a "*posterior face* having a rounded outer peripheral edge extending from the anterior face to the posterior face." CooperVision argues that the difference in language between claim 13 of the '706 patent and claim 1 and 7 of the '538 patent does not alter the scope of the claim. CooperVision concludes that a "rounded outer peripheral edge surface" in claim 13 describes the shape of the posterior surface of the lens formed by a back surface tool with a convexly-curved peripheral edge surface.

The patentee in this case had unbridled discretion in his choice of words, and he chose not to modify "a rounded outer peripheral edge" with the word "posterior face" in Claims 1 and 7 of the '538 patent. Therefore, CooperVision cannot successfully argue that the outer peripheral edge *must* be created by a back surface tool and that it *must* be part of the posterior lens simply because another claim in another patent uses a similar term. Rather, the patents indicate that a rounded outer peripheral edge extends from the anterior face of the lens to the posterior face of the lens. *See* '538 patent, col.8, ll. 13-15; '706 patent, col. 9, ll. 9-12.

As stated above when construing the "rounded edge" element of Claim 4 of the '706 patent, even if CooperVision is correct that the anterior face may contain a point after being made in the conventional manner and that the claim term refers to the posterior surface edge of a contact lens, this does not mean the court should define the edge in terms of a specific tool.

For the reasons also discussed above, CIBA's definition may mislead a reader into thinking that the edge is restricted to a circle, or an approximately circular shape. For that reason, it also is not adopted.

Having considered all relevant factors, the court finds that:

"A lens body comprising a hydrogel material and having an anterior face, a posterior face, and a rounded outer peripheral edge surface ..." means: **a lens body comprising a hydrogel material and having an anterior face, a posterior face, and a substantially smooth, curved outer peripheral edge ..."**

"A lens body comprising a hydrophilic silicone-containing material having an anterior face, a posterior face having a rounded outer peripheral edge surface ..." means: **a lens body comprising a hydrophilic silicone-containing material having an anterior face and a posterior face having a substantially smooth, curved outer peripheral edge ..."**

5. "[T]he lens body formed by a process including cast molding using a first polymeric mold section having a surface in a general shape of a negative of the posterior face and a concave outer peripheral surface." Used in '538 patent, claims 1 and 7; '706 patent, claim 13.

CooperVision argues that this term should be construed as "the lens body is formed by a process including cast molding using a polymeric mold section having a surface in a general shape of a negative of an insert tool that has a first surface portion and a convexly curved peripheral edge surface." CIBA proposes "the lens body is formed by a process including cast molding using a first polymeric mold section having a surface in a general shape of a negative of the posterior face of the lens and the entire outer peripheral surface of the first polymeric mold section is curved inward like the inside of a bowl so as to produce a contact lens with a rounded outer peripheral edge surface."

Claim 13 of the '706 patent and claims 1 and 7 of the '538 patent recite a lens that has a rounded edge formed by mold section. The mold section must have a first surface "in the general shape of a negative of the posterior face" of the lens and must have a second, outer peripheral surface that is "concave."

The specification defines a mold with a "concave outer peripheral surface" in terms of the "negative of the back surface tool with a convexly-curved peripheral surface that created the mold." '706 patent, col. 2, ll. 40-52; col. 6, ll. 48-57. For example, it states that "[t]he portion of the back surface tool that forms the lens periphery is convex in form ... Correspondingly, the first mold section formed by the tooling insert has a concave outer edge surface." '706 patent, col. 3, ll. 16-20.

As previously discussed, CIBA's definition improperly adds that the outer peripheral edge surface must be "rounded." A contact lens with a rounded edge surface is only a preferred embodiment. *See* '706 patent, col. 3, ll. 52-53. Additionally, CIBA inserts the word "entire" before "outer peripheral surface," which may seem as if the surface cannot be comprised of small flats closely simulating a continuous curve. There is no basis to import such a limitation from the specification to this claim term.

The court defines this term as follows:

"[T]he lens body formed by a process including cast molding using a first polymeric mold section having a surface in a general shape of a negative of the posterior face and a concave outer peripheral surface" means: the lens body formed by a process including cast molding using a polymeric mold section having a surface in a general shape of a negative of the posterior face of the lens and a concave curved peripheral surface. A concave curve is the negative image of a convex curve.

B. The Toric Patents

1. "[A] peripheral zone being defined adjacent the peripheral edge of the anterior face that is tapered thinner toward the peripheral edge of the lens." Used in '740 patent, claim 1.

"[A] peripheral zone being defined adjacent the peripheral edge of the lens that tapers thinner toward the peripheral edge of the lens." Used in '903 patent, claim 29, 34, 38.

"[A] peripheral zone adjacent the peripheral edge of the anterior lens." Used in '746 patent, claim 1.

CooperVision proposes "a portion of the lens with a decreasing thickness to provide a ramp from a ballast periphery to the lens edge, to create a comfort zone around the edge of the lens." CIBA contends that this term should mean "a zone or region on the anterior face of the lens that is tapered thinner toward the peripheral edge of the lens, is located adjacent to the peripheral edge, and that circumscribes and is separated from the INNER ZONE by either a curved or rounded transition (i.e., an area of the lens that creates a smooth junction between adjacent curvatures) or by a discrete boundary, discontinuity or corner (collectively, 'boundary'). The boundary separating the zones is the only such identifiable boundary between the peripheral edge and the boundary of the optic zone."

The parties do not dispute that a peripheral zone can be construed similarly among the Toric patents. The claim language describes a contact lens comprising a contact lens body with an anterior face, a posterior face, and "a peripheral edge therebetween with a peripheral zone being defined adjacent the peripheral edge of the anterior face that is tapered thinner toward the peripheral edge of the lens body." '740 patent, col. 11, ll. 42-46.

The present invention includes three zones on the anterior face of the lens: an optic zone, an inner zone, and a peripheral zone circumscribing the inner zone. '903 patent, col. 4, ll. 5-7; col. 5, ll. 50-55. Although smooth, rounded transitions between the different zones are preferred, discrete boundaries or corners are not excluded. '903 patent, col. 10, ll. 15-17. The peripheral zone is adjacent to the peripheral edge of the lens and tapers so as to be thinner at the lens edge than at the inner zone. '903 patent, col. 3, ll. 65-67; col. 6, ll. 6-7. This taper within the peripheral zone provides a "so-called" comfort zone around the edge of the lens. '903 patent, col. 9, ll. 5-7. Because of the reduced thickness, movement of the eyelids across the contact lens is facilitated, and there is less irritation. *Id.*

CooperVision's assertion that the peripheral zone extends to a ballast periphery is unsupported by the specification. The specification provides that the *inner zone* has a *circular* ballast periphery that is slightly offset toward the top of the lens along a vertical meridian. '903 patent, col. 6, ll. 3-5 (emphasis added). The ballast surface may be contained wholly within the inferior portion of the inner zone. '903 patent, col. 6, ll. 59-61; col. 10, ll. 39-44. If CooperVision's construction is adopted, then the peripheral zone would encompass a large portion of the lens, rather than around the edge of the lens, when the ballast surface is contained wholly within the inferior portion. This would contradict what is required by the patents. *See* '903 patent, col. 9, ll. 5-6. Although in one "exemplary embodiment" discussed in '903 patent, col. 7, ll. 48-50, the lens tapers downward within the peripheral zone between the ballast periphery to the inferior edge, the court will not import limitations from a preferred embodiment into the construction of claims. *Electro Med. Sys. S.A. v. Cooper Life Sciences, Inc.*, 34 F.3d 1048, 1054 (Fed.Cir.1994).

In its proposed construction, CIBA places the limitation that there can only be one transition between the optic zone and the peripheral edge of the lens. CIBA also states that there must be distinct boundaries between each zone. The court rejects this construction based on *Gillette Co. v. Energizer Holdings, Inc.*, 405 F.3d 1367, 1374 (Fed.Cir.2005). There, the Federal Circuit followed the maxim that claims will not be read restrictively unless the patentee has demonstrated a clear intention to limit the claim scope using words or expressions of manifest exclusion or restriction. In that case, the patent-in-suit claimed a wet-shave safety razor with multiple blades. *Id.* at 1369. Specifically, the patent claimed a "safety razor comprising ... a group of first, second, and third blades," but the defendant manufactured a four-blade safety razor. *Id.* After reviewing the patent specification, the Federal Circuit determined that the invention relates to safety razors having blade units with a plurality of blades and despite numerous cites to three-bladed razors, "no statement in the patent surrenders or excludes a four-bladed razor." *Id.*

The written description of the Toric Patents is similar to the written description in *Gillette* in that the written description defines a claim term but nonetheless provides a disclosure of examples of limited scope. The specification states that the anterior face defines a "plurality of zones thereon" In fact, the patentee stressed that "although the present application describes distinct zones or portions in contact lenses, those zones are shown for clarity of description of the invention only.... [T]here are no sharp distinctions between these different zones of the lens, but that, they are instead smoothly blended into one another." '903 patent, col. 8, ll. 62-67. Moreover, the specification teaches:

the clear delineations in the drawings between the optic zone **22** peripheral zone **24** and inner zone **26** should not be taken to imply that there is a discontinuity or corner at those locations, and in fact the exemplary lens of the present invention possesses gradually curved transitions between the zones. '903 patent, col. 8, ll. 62-67.

Analogously, between the different portions (i.e., superior, intermediate, and inferior) the present invention may have either smooth, rounded transitions or discrete boundaries or corners. '903 patent, col. 10, ll. 15-17.

There is no authority for the addition of superfluous limitations in claim construction, and certainly not from description of the preferred embodiment, even if they may later be useful to the infringement analysis of a party. The claim language at issue involves only the peripheral zone, and the court will not include additional language involving the number of zones or transitions. That is a matter for another time.

The court defines these terms as follows:

"[A] peripheral zone being defined adjacent the peripheral edge of the anterior face that is tapered thinner toward the peripheral edge of the lens" and "a peripheral zone being defined adjacent the peripheral edge of the lens that tapers thinner toward the peripheral edge of the lens" and "a peripheral zone adjacent the peripheral edge of the anterior lens" means: **A zone or region on the anterior face of the lens located adjacent to the peripheral edge, and that circumscribes and is separated from the inner zone by either a curved or rounded transition or by a discrete boundary, discontinuity or corner. The zone has a decreasing thickness toward the peripheral edge of the lens to provide comfort to the wearer.**

2. "[A]n inner zone on the anterior face circumscribed by the peripheral zone and surrounding the optic zone." Used in '740 patent, claim 1.

"[A]n inner zone circumscribed by the peripheral zone." Used in '903 patent, claims 29, 34 and 38.

"[T]he anterior face including an inner zone circumscribed by the peripheral zone, and an optic zone in the inner zone." Used in '746 patent, claim 1.

"[A] second zone circumscribing the optical [optic] zone." Used in '763 patent, claim 15; '174 patent, claim 16.

The parties agree that "second zone" is interchangeable with "inner zone." The parties also agree that certain zones must be defined on the anterior face of the lens and may include the optic zone, the inner zone and the peripheral zone.

CooperVision argues that these terms should be defined as "a portion of the lens circumscribed by the peripheral zone and that surrounds the optic zone and [a Transition Area] between the inner zone and the peripheral zone." CIBA contends that these terms mean "a zone or region on the anterior face of the lens that is circumscribed by the peripheral zone and surrounds the optic zone (or has a portion that surrounds the remainder of the inner zone that makes up the optic zone). The inner or second zone is separated from the optic zone (or the portion of the inner zone that makes up the optic zone) by a boundary. The outer edge of the inner or second zone (where the inner or second zone meets the peripheral zone) is also separated from the peripheral zone by a boundary, which is the only identifiable boundary between the peripheral edge of the lens and the boundary of the optic zone."

CooperVision defines a Transition Area as "a rounded or curved transition or a discrete boundary, discontinuity, or corner (a 'Transition Area') between zones on the lens." In the interest of the jurors, the court will adopt but reword CooperVision's proposal for readability purposes.

Moreover, for the reasons discussed above, the court will not import CIBA's proposed limitation that there be only one identifiable boundary between the peripheral edge of the lens and the boundary of the optic zone, when the claim language discusses only the inner zone.

The court defines these terms as follows:

"[A]n inner zone on the anterior face circumscribed by the peripheral zone and surrounding the optic zone" and "an inner zone circumscribed by the peripheral zone." and "[T]he anterior face including an inner zone circumscribed by the peripheral zone, and an optic zone in the inner zone" and "a second zone circumscribing the optical [optic] zone" means: **A zone or region on the anterior face of the lens located adjacent to the peripheral zone, and that circumscribes and is separated from the optic zone by either a curved or rounded transition or by a discrete boundary, discontinuity or corner.**

3. "[B]allast Portion." FN4 Used in ' 740 patent, claim 1; ' 746 patent, claims 1, 4, 7 and 8.

FN4. The parties agree that once the dispute regarding the definition of ballast portion is resolved, the definition of prism ballast portion will be "a ballast portion that includes the optic zone."

CooperVision contends that this term means "a portion of a ballast. A ballast being a surface contour of the lens that has a varying thickness to re-orient the lens." CIBA proposes "a surface contour of the lens that has a varying thickness to re-orient the lens and that has consecutive horizontal cross sections throughout the entire structure each of which has substantially uniform thickness not varying by more than approximately 30 (μ)m or 20% of the minimum thickness of the cross section."

The central differences between the proposed constructions are whether 1) "ballast portion" refers to a portion of a ballast rather than the portion of the lens with ballast, and 2) the entire ballast must have iso-thickness. *See* ' 903 patent, col. 6, ll. 55-61 ("The term iso-thickness means that each of the consecutive horizontal cross sections has a substantially uniform thickness not varying by more than 30 (μ)m or 20% ...").

The patent is for a contact lens "having improved thickness and ballast arrangement." '903 patent, col. 3, ll. 6-9. The heart of the invention is a particular type of ballast with isothickness. When the PTO allowed the

claims, the examiner stated that "[t]he prior art fails to teach a combination of all the claimed features as presented, for example, in independent claim 1, which includes a contact lens having an improved ballast that imposes a low-torque rotational correction on the lens." Notice of Allowance, 03/22/2002, p. 2, Ex. 13 to Defendant's Responsive Claim Construction Brief. Thus, the feature of an improved ballast was added to distinguish the present invention from the prior art.

The Abstract explains that "the prism ballast is provided on one or more portions of the anterior face of the lens such that the lens body has a uniform thickness of within 10% along horizontal cross-sections." *See also* '903 patent, col. 6, ll. 39-42. The "iso-thickness ballast surfaces are formed in at least 20% ... and more preferably at least 100%, of at least one of the superior, intermediate, and inferior portions **40**, **44**, and **48** as a series of consecutive horizontal cross-sections" '903 patent, col. 6, ll. 44-50. Figure 5d gives an example of the ballast portion **102** located entirely within the inferior portion of the inner zone.

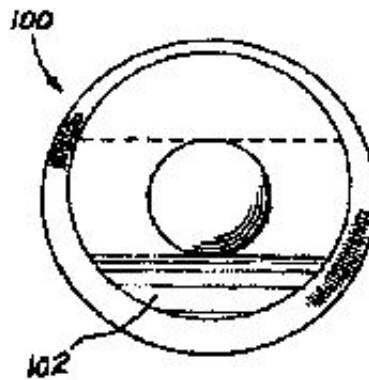

Fig. 5d

CooperVision contends that the portions of the inner zone where ballast is not specified in Figures 5a-5d contain non-iso-thickness ballast structures. It is clear from the specification and the figures that the entire inner zone need not contain ballast. Figures 5a-5d illustrate the complete and only ballast surfaces of the lens. Nothing in the specification supports CooperVision's argument that there are other ballast surfaces or portions not illustrated in the figures. Therefore, ballast portion is the portion of the lens with ballast, not simply a portion of the ballast itself. This comports with the following text from the specification:

The present invention provides that consecutive horizontal cross-sections shown in FIG. 2 that possess ballast each has a substantially uniform or iso-thickness, except in optic zone **22** and peripheral zone **24**. For example, one of the cross-sections in Fig. 2 having ballast, such as D-D", has a substantially uniform thickness. Alternatively, all of the cross-sections shown in Fig. 2 that possess ballast may have a uniform thickness except in the optic zone **22** and peripheral zone **24**. '903 patent, col. 7, ll. 13-21.

The specification also states that "the sections of substantially uniform thickness do not vary in thickness *within one section* by more than about 30 (μ)m or 20% whichever is greater in absolute terms." '903 patent, col. 7, ll. 23-25 (emphasis added). One skilled in the art could ascertain from this description that the entire lens need not contain ballast, but the section or portion that does have ballast also has substantially

uniform or iso-thickness.

That is not to say that the entire lens can *only* have an iso-thickness ballast arrangement. *See* '903 patent, col. 11, ll. 25-27. CooperVision correctly points out that the Toric Patents claim techniques useful for creating high performing lenses that contain rotational stabilization structures other than iso-thickness, such as the Meridian Width and A to B Ratio features. But even if the Meridian Width and A to B Ratio are other techniques for re-orienting the lens, whether all ballast must have iso-thickness is a separate issue.

CooperVision also relies on dependent claims 31 and 36, which add the specific limitation of a ballast portion with iso-thickness. However, claims 31 and 36 also contain limitations other than iso-thickness, so the presumption of claim differentiation does not apply.

The claim itself limits the ballast portion to those with "a series of horizontal cross-sections ... wherein each horizontal cross-section has a substantially uniform thickness not varying by more than 30 (μ)m." '746 patent, col. 12, ll. 4-13. CIBA's proposed definition, therefore is redundant, and there is no need to repeat those words in the definition of "ballast portion."

The court defines this term as follows:

"Ballast portion" means: **The portion of the lens with ballast. Ballast is a surface contour of the lens that has elevated surfaces that interact with the blinking action of the eyelids to re-orient the lens.**

4. "[T]he thickness is substantially equal on the left side region of the second zone and the right side region of the second zone." Used in '753 patent, claim 15.

CooperVision proposes "the second zone includes a series of cross-sections that each has a substantially uniform thickness not varying by more than about 30 (μ)m or 20% of the minimum thickness within the cross-section. The area of the second zone to the left of the vertical meridian has a thickness topography that is symmetric with a thickness topography of the area of the second zone to the right of the vertical meridian." CIBA contends "at any given horizontal cross-section, the thickness is approximately the same across the entire horizontal cross-section on the left side region of the second zone and the right side region of the second zone."

In their briefing to the court, the parties agreed that the relevant area of analysis is the entire inner or second zone, which excludes the optic and peripheral zone. The parties also agreed that substantial uniformity means no more than about 30 (μ)m or 20%. *See* '903 patent, col. 7, ll. 22-30; col. 6, ll. 55-58. At the hearing, moreover, CooperVision agreed that in the horizontal direction, cross-sections must be substantially uniform. The remaining dispute, therefore, is whether the cross-sections must also be symmetrical so that every point on the left side is a mirror image of a point on the right side.

Claim 3 of the '753 patent shows that the patentee knew how to claim vertical symmetry and chose not to do so in claim 15. *See* '753 patent, claim 3 (requiring a lens thickness profile that "is symmetrical with respect to the vertical meridian"). Unlike claim 3, claim 15 requires only that *regions* of the left and right sides be "substantially equal." There is no reason to conclude that "substantially equal" in claim 15 is actually two limitations in one, and that it actually includes a symmetry requirement. CooperVision's construction inaccurately requires the thickness topography to be symmetrical.

The court defines this term as follows:

"[T]he thickness is substantially equal on the left side region of the second zone and the right side region of the second zone" means: **the second zone includes a series of horizontal cross-sections each having substantially uniform thickness not varying by more than about 30 (μ)m or 20% of the minimum thickness on the left side region and the right side region.**

5. "[W]herein, along a ___ (deg.) meridian, the distance between the inner zone and the peripheral edge is less than 1.3mm." Used in '903 patent, claims 29 and 34.

"[A] superior distance A being defined along the vertical meridian and within the inner zone from the optic zone to the peripheral zone, and an inferior distance B being defined along the vertical meridian and within the inner zone from the optic zone to the peripheral zone, and wherein $.33A \leq B \leq A$." Used in '903 patent, claim 38.

The dispute is about how to measure the distances described in the two limitations above. CooperVision believes the distance between two points on a contact lens should be measured by the straight line distance between the two points. CIBA believes that the distance between the two points should be measured over the lens curvature (the "arc length").

CooperVision proposes "the distance, measured as a straight line, between the ballast periphery and the peripheral edge of the contact lens body is less than about ___ mm along the ___ (deg.) meridian. The ___ meridian is found by starting with zero degrees at the 3:00 position and moving counterclockwise around the circle of the lens." CIBA proposes "the distance, measured along the curve of the anterior face of the lens, between the outermost edge of the inner zone and the peripheral edge of the contact lens body is less than approximately ___ mm along the ___ meridian, which is found by starting with zero degrees at the 3:00 position and moving counterclockwise around the circle of the lens."

The Toric Patents do not explain how claim distances are to be calculated. However, the specification explains that "thickness is measured *radially with respect to the curvature of the anterior face*" of the lens. '903 patent, col. 9, ll. 24-26 (Italics added). There is no indication that the peripheral zone width and A:B ratio measurements should be made in any other way. Given that the patent discloses a methodology of measuring thickness using the curvature of the anterior face, the court finds that method of measurement is appropriate for these claims. FN5

FN5. CIBA further directs the court's attention to the specification referring to a "flattened" lens. *See* '903 patent, col. 5, ll. 22-40 ("For simplicity, *the elevational views shown herein are flattened*, with the base sphere removed ... so that the particular surfaces and thicknesses of the present invention can be more clearly illustrated." (Italics Added.)) This may lend credence to CIBA's argument that a linear measurement may be made after a contact lens is flattened, which is tantamount to measuring the arc length.

The court defines these terms, respectively, as:

"[W]herein, along a ___ (deg.) meridian, the distance between the inner zone and the peripheral edge is less than 1.3mm" means: **the distance between the outermost edge of the inner zone and the peripheral edge of the contact lens body, measured along the curve of the anterior face of the lens, is less than**

approximately ___ mm along the ___ (deg.) meridian, which is found by starting with zero degrees at the 3:00 position and moving counterclockwise around the circle of the lens.

"[A] superior distance A being defined along the vertical meridian and within the inner zone from the optic zone to the peripheral zone, and an inferior distance B being defined along the vertical meridian and within the inner zone from the optic zone to the peripheral zone, and wherein $.33A \leq B \leq A$ " means: **Where A is defined along the vertical meridian and within the inner zone from the optic zone to the peripheral zone, measured along the curve of the anterior face of the lens, and B is defined along the vertical meridian and within the inner zone from the optic zone to the peripheral zone, measured along the curve of the anterior face of the lens, then $.33A \leq B \leq A$.**

6. "[M]olded prism ballast portion." Used in '903 patent, claim 38.

CooperVision contends that this term means "a prism ballast portion made with front surface and back surface molds without subsequent machining or polishing." CIBA proposes "a prism ballast portion that is manufactured primarily in a mold."

CooperVision's construction would impermissibly read into claim 38 a limitation that the prism ballast portion be "fully molded" i.e. molded without any post-processing steps. Claim 38 of the '903 patent does not disclose a "fully molded" contact lens as do claims 29 and 34. A more generic description of "molded" accords with the text of claim 38, and it does not impermissibly read into claim 38 the limitation of a mold without need for subsequent machining or polishing.

The court defines this term as follows:

"[M]olded prism ballast portion" means: **a prism ballast portion that is manufactured primarily in a mold.**

IV. CONCLUSION

The jury shall be instructed in accordance with the court's interpretations of the disputed claim terms in the '706, '538, '903, '740, '746, '174 and '753 patent.

E.D.Tex., 2007.

CooperVision, Inc. v. CIBA Vision Corp.

Produced by Sans Paper, LLC.