

United States District Court,
D. Kansas.

Mark A. FREEMAN and Timothy K. Stringer,
Plaintiffs.

v.

GERBER PRODUCTS COMPANY,
Defendant.

Mark A. Freeman and Timothy K. Stringer,
Plaintiffs.

v.

Playtex Products, Inc,
Defendant.

Nos. 02-2249-JWL, 02-2250-JWL

Feb. 17, 2005.

Background: Owners of patent for spill-proof closure for beverage container sued "sippy cup" manufacturers for infringement. The United States District Court for the District of Kansas, 2003 WL 22410330, ruled that patent was invalid as indefinite, and owners appealed. The Court of Appeals, 120 Fed.Appx. 322, reversed and remanded.

Holdings: On remand, the District Court, Lungstrum, J., held that:

- (1) "controllable valved closure" was not limited to suction-controlled valve;
- (2) structure for performing function of "selectively maintaining said closure in covering relation with said container" was friction fit between lid and container, as depicted in patent's drawings; and
- (3) "thin membrane having attachable means" was thin, soft, pliable sheet having wall around its perimeter.

Claims construed.

5,186,347. Construed.

Adam P. Seitz, Bart Alan Starr, Basil Trent Webb, Shook, Hardy & Bacon L.L.P., Kansas City, MO, for Plaintiff.

Laurence R. Tucker, Armstrong Teasdale LLP, Kansas City, MO, Matthew G. Reeves, Michael O. Sutton, Locke, Liddell & Sapp LLP, Houston, TX, James P. Barabas, Robert J. Gunther, Latham & Watkins LLP, New York, NY, Matthew B. Lehr, Menlo Park, CA, Paul S. Penticuff, Thomas N. Sterchi, Baker, Sterchi, Cowden & Rice, L.L.C., Kansas City, MO, for Defendants.

MEMORANDUM AND ORDER

LUNGSTRUM, District Judge.

Plaintiffs Mark A. Freeman and Timothy K. Stringer own United States Patent No. 5,186,347 (the '347 patent), which is a patent for a spill-proof closure used in dispensing liquid beverages. They allege that certain sippy cups sold by the defendants in these consolidated cases, Gerber Products Company (Gerber) and Playtex Products, Inc. (Playtex), infringe certain claims of the '347 patent. The matter is before the court on plaintiffs' request pursuant to *Markman v. Westview Instruments, Inc.*, 52 F.3d 967 (Fed.Cir.1995) (en banc), *aff'd*, 517 U.S. 370, 116 S.Ct. 1384, 134 L.Ed.2d 577 (1996), for the court to construe claims 7 and 14 of the '347 patent as a matter of law.

The court held a *Markman* hearing and issued a memorandum and order holding claims 7 and 14 of the '347 patent were invalid on the grounds that certain means-plus-function claim limitations were indefinite in scope because they failed to sufficiently identify structures to perform the recited functions. *See generally* *Freeman v. Gerber Prods. Co.*, 284 F.Supp.2d 1290 (D.Kan.2003). The court subsequently entered summary judgment in favor of defendants, *see generally* *Freeman v. Gerber Prods. Co.*, Nos. 02-2249 & 02-2250, 2003 WL 22410330, at *1-*2 (D.Kan. Oct.21, 2003), and defendants appealed. The Federal Circuit reversed, holding the '347 patent adequately disclosed structures corresponding to the functions claimed in the means-plus-function claim limitations, and remanding for this court to construe the claims. *See generally* *Freeman v. Gerber Prods. Co.*, 120 Fed.Appx. 322, 325 (Fed.Cir.2005).

The parties filed supplemental briefs addressing the effect of the Federal Circuit's ruling on the means-plus-function claim limitations. The court has reviewed those briefs and is now prepared to construe claims 7 and 14 of the '347 patent. As a matter of law, the court determines that those claims have meaning and scope as set forth below.

LEGAL STANDARDS FOR CLAIM CONSTRUCTION

[1] [2] Patent infringement analysis involves two steps: first, properly construing the asserted claim; and, second, determining whether the accused method or device infringes the asserted claim as properly construed. *Markman*, 52 F.3d at 976. Step one-claim construction-is a matter of law to be resolved by the court. *Id.* at 970-71. The purpose of claim construction is to determine how one of ordinary skill in the art would have understood the claims at the time the patent was issued. *Innova/Pure Water, Inc. v. Safari Water Filtration Sys., Inc.*, 381 F.3d 1111, 1116 (Fed.Cir.2004). The intrinsic record is the primary source for determining the meaning of the claim. *C.R. Bard, Inc. v. U.S. Surgical Corp.*, 388 F.3d 858, 861 (Fed.Cir.2004); *Goldenberg v. Cytogen, Inc.*, 373 F.3d 1158, 1164 (Fed.Cir.2004). The court consults intrinsic evidence in the following order: (1) the claim language itself; (2) the other portions of the written description; and, (3) if in evidence, the prosecution history. *Alza Corp. v. Mylan Labs., Inc.*, 391 F.3d 1365, 1370 (Fed.Cir.2004); *Vitronics Corp. v. Conceptronic, Inc.*, 90 F.3d 1576, 1582 (Fed.Cir.1996).

[3] [4] [5] The court begins by focusing on the language of the claims themselves. "There is a 'heavy presumption' that the terms used in the claims 'mean what they say and have the ordinary meaning that would be attributed to those words by persons skilled in the relevant art.'" *SuperGuide Corp. v. DirecTV Enters., Inc.*, 358 F.3d 870, 874-75 (Fed.Cir.2004) (quoting *Texas Digital Sys., Inc. v. Telegenix, Inc.*, 308 F.3d 1193, 1202 (Fed.Cir.2002), *cert. denied*, 538 U.S. 1058, 123 S.Ct. 2230, 155 L.Ed.2d 1108 (2003)). The court may consult dictionary definitions for assistance in establishing a claim term's ordinary meaning as

understood by a person of ordinary skill in the relevant art. *Apex Inc. v. Raritan Computer, Inc.*, 325 F.3d 1364, 1371 (Fed.Cir.2003); *Texas Digital Sys.*, 308 F.3d at 1202. Unless otherwise compelled, the court must "give a claim term the full range of its ordinary meaning as understood by persons skilled in the relevant art." *Riverwood Int'l Corp. v. R.A. Jones & Co., Inc.*, 324 F.3d 1346, 1357 (Fed.Cir.2003).

[6] [7] Next, the court reviews the "written description and drawings to confirm that the patentee's use of the disputed term is consistent with the meaning given to it by the court." *SuperGuide Corp.*, 358 F.3d at 875. The heavy presumption that claim terms carry their ordinary and customary meaning is rebutted if "the patentee, acting as his or her own lexicographer, has clearly set forth an explicit definition of the term different from its ordinary meaning" or if the inventor has clearly disavowed the scope of the claim. *Texas Digital Sys.*, 308 F.3d at 1204. Although an understanding of the claim language may be aided by the written description, claim limitations that are not a part of the claim should not be imported from the written description. *SuperGuide Corp.*, 358 F.3d at 875. "[L]imitations may not be read into the claims from the written description." *Prima Tek II, L.L.C. v. Polypap, S.A.R.L.*, 318 F.3d 1143, 1148 (Fed.Cir.2003). Admittedly, however, there is sometimes "a fine line between reading a claim in light of the specification, and reading a limitation into the claim from the specification." *Comark Communications, Inc. v. Harris Corp.*, 156 F.3d 1182, 1186 (Fed.Cir.1998).

[8] "After examining the written description and the drawings, the same confirmatory measure must be taken with the prosecution history, since statements made during the prosecution of a patent may affect the scope of the invention." *Rexnord Corp. v. Laitram Corp.*, 274 F.3d 1336, 1343 (Fed.Cir.2001). During prosecution, an inventor may surrender coverage of material that would otherwise be covered by a claim; however, the surrender must be clear and unmistakable. *Omega Eng'g, Inc. v. Raytek Corp.*, 334 F.3d 1314, 1325-26 (Fed.Cir.2003).

[9] The court may also consult extrinsic evidence, but only for the purpose of allowing the court to gain an understanding of the claim terminology. *Markman*, 52 F.3d at 986; *Astrazeneca AB, Aktiebolaget Hassle, KBI-E, Inc. v. Mutual Pharm. Co.*, 384 F.3d 1333, 1337 (Fed.Cir.2004) (extrinsic evidence can be useful for shedding useful light on the relevant art). It is well settled that extrinsic evidence "cannot be used to alter a claim construction dictated by a proper analysis of the intrinsic evidence." *On- Line Tech. v. Bodenseewerk Perkin-Elmer GmbH*, 386 F.3d 1133, 1139 (Fed.Cir.2004); *see also Markman*, 52 F.3d at 980-81 (extrinsic evidence may not be used to vary the meaning disclosed by the patent itself). FN1

FN1. The parties, especially plaintiffs, have submitted expert declarations that they ask the court to consider in construing the claim terms. Although the court has thoroughly considered the content of these declarations, the court has not devoted much attention to them in this memorandum and order because it does not find them helpful to understanding the claim terminology, which is relatively simple and not particularly technical. This evidence, if given any weight, would vary the meaning of some of the claim terms from their proper claim construction as dictated by an analysis of the intrinsic evidence.

CLAIM 7

Claim 7 of the '347 patent reads as follows:

A controllable valved closure for use in dispensing a beverage from a container, said closure comprising:

- (a) a substantially planar cover portion conforming in shape to the opened end of said container;
- (b) attachable means for selectively maintaining said closure in covering relation with said container;
- (c) an elongated passageway having an outer end, said passageway extending upwardly and outwardly from said cover portion;
- (d) an opening located near said outer end of said passageway, said opening providing communication between the interior and exterior of said passageway, and said opening being completely contained within the user's mouth during operation of the closure;
- (e) a thin membrane having attachable means for attaching said thin membrane to an inner surface of said closure, said thin membrane covering said opening in said passageway; and
- (f) a slit through a planar section of said thin membrane, said slit functioning to provide an opening through said thin membrane when an external negative pressure exists and remain closed when internal and external pressures are equal.

The parties dispute the proper claim construction of many of these claim elements. The court construes those disputed claim limitations as follows.

A. Preamble to Claim 7: "A *controllable valved closure* for use in dispensing a beverage from a container, said closure comprising:"

Plaintiffs ask the court to construe the terms "controllable valved closure" in the preamble as "a lid having a suction-controlled valve." In response, Gerber argues that no construction is necessary because the term "controllable valved closure" simply names the invention and the remainder of the preamble merely recites the intended use of the invention. Playtex concurs with Gerber, but alternatively contends that if the court decides that the preamble is a limitation, it should be construed as "a cover (or lid) with a controllable valve for dispensing beverages from a container." The court, then, must address two issues with respect to the preamble: (1) whether the preamble is a claim limitation; and (2) if so, how to construe this limitation.

[10] "Whether to treat a preamble as a claim limitation is determined on the facts of each case in light of the claim as a whole and the invention described in the patent." *Storage Tech. Corp. v. Cisco Sys., Inc.*, 329 F.3d 823, 831 (Fed.Cir.2003). On the one hand, "a preamble generally limits the claimed invention if it recites essential structure or steps, or if it is necessary to give life, meaning, and vitality to the claim," *NTP, Inc. v. Research In Motion, Ltd.*, 392 F.3d 1336, 1358 (Fed.Cir.2004) (quotation omitted), "or when the preamble contributes to the definition of the claimed invention," *C.R. Bard, Inc. v. M3 Sys., Inc.*, 157 F.3d 1340, 1350 (Fed.Cir.1998). On the other hand, a preamble does not serve as a claim limitation where it only states a purpose or intended use of the invention. *Poly-Am., L.P. v. GSE Lining Tech., Inc.*, 383 F.3d 1303, 1310 (Fed.Cir.2004).

[11] Here, the preamble does more than state the purpose or intended use of the invention. Gerber correctly points out that the preamble recites the intended use of the closure, which is "for use in dispensing a beverage from a container." But this is only a portion of the preamble. The other component of the preamble is the "controllable valved closure" that is put to this use. This limitation does not merely name the invention. The '347 patent names the invention as a "spill-proof closure." The preamble to claim 7, on the

other hand, uses the adjectives "controllable valved" to describe the closure. In doing so, the preamble begins to describe how the closure is made to be spill proof. Hence, the term "controllable valved closure" contributes to the definition of the claimed invention. Indeed, it represents the fundamental characteristic of the invention. *See, e.g., Poly-Am., L.P.*, 383 F.3d at 1310 (holding the district court properly held that a preamble claiming a "blown-film textured liner" served as a claim limitation because it disclosed a fundamental characteristic of the claimed invention).

Moreover, claim elements 7(b), 7(d), and 7(e) derive antecedent basis from the preamble, as they refer to "said closure" and "the closure." "When limitations in the body of the claim rely upon and derive antecedent basis from the preamble, then the preamble may act as a necessary component of the claimed invention." *NTP, Inc.*, 392 F.3d at 1359 (quotation omitted); *accord Eaton Corp. v. Rockwell Int'l Corp.*, 323 F.3d 1332, 1339 (Fed.Cir.2003). The limitation "controllable valved closure," then, is also necessary to provide context for these claim elements. Thus, plaintiffs used the body of the claim in conjunction with the preamble to define the subject matter of the claimed invention. Accordingly, "controllable valved closure" in the preamble of claim 7 is a claim limitation.

[12] The more pivotal issue is whether this limitation requires any further claim construction. Plaintiffs and Playtex agree that the term "controllable valved closure" refers to a lid having a controllable valve; their point of disagreement is whether to define the valve as simply a "controllable" valve or a "suction-controlled" valve. The court begins by focusing on the language of the claim. The preamble claims a "controllable valved closure." "Controllable" is defined as "capable of being controlled." *Webster's Third New International Dictionary Unabridged* 497 (1993). "Controlled," in turn, is defined as "restrained, managed, or kept within bounds ... conducted or maintained in accordance with fixed rules, restraints, or procedures." *Id.* "Valved" is defined as "provided or equipped with valves." *Id.* at 2531. The relevant definition of "valve" is "any of numerous mechanical devices by which the flow of liquid ... may be started, stopped, or regulated by a movable part that opens, shuts, or partially obstructs one or more ports or passageways." *Id.* Thus, the ordinary meanings of the terms "controlled" and "valved" do not warrant importing the term "suction" into the preamble.

Plaintiffs nonetheless argue that claim elements 7(d) ("said opening being completely contained within the user's mouth during operation of the closure") and 7(f) ("said slit functioning to provide an opening through said thin membrane when an external negative pressure exists and remain closed when internal and external pressures are equal") warrant such a result. FN2 It is true that "a claim preamble has the import that the claim as a whole suggests for it." *Bell Communications Research, Inc. v. Vitalink Communications Corp.*, 55 F.3d 615, 620 (Fed.Cir.1995); *accord Eaton Corp.*, 323 F.3d at 1339; *Griffin v. Bertina*, 285 F.3d 1029, 1033 (Fed.Cir.2002). But even considering the limitations set forth in claim element 7(d) and 7(f), the court is unpersuaded that claim 7 is limited to a suction-controlled valve. Certainly, claim element 7(d) in conjunction with claim element 7(f) together create a colorable argument that the court should import the word "suction" into the preamble. One of the dictionary definitions of "suction" relates to negative pressure. *See Webster's, supra*, at 2283 (defining suction drainage as the process of removing fluids by means of a tube and a device that operates on negative pressure). But the primary definition of the term suction is "the act or process of sucking." *Id.* Indeed, this is the definition that is most apropos to the '347 patent. "Suck," in turn, is defined as drawing a liquid into the mouth by a partial vacuum caused by a motion of the mouth. *Id.* The word "suck," then, is defined in terms of a partial vacuum, not in terms of negative pressure. But, then again, one of the definitions of the term "suction" relates to negative pressure. In sum, although suction may be one form of negative pressure, the predominant meaning of the word "suction" does not evidence that negative pressure necessarily means suction and only suction such that claim 7 is necessarily limited to

claiming a valved closure that is controlled only by suction.

FN2. To the extent that defendants contend that claim elements 7(d) and 7(f) are not limitations, the court disagrees. The only case defendants cite in support of their argument is *In re Schreiber*, 128 F.3d 1473 (Fed.Cir.1997), and they cite this case for the proposition that "it is well settled that the recitation of a new intended use for an old product does not make a claim to that old product patentable." Patentability, however, is not at issue here; rather, the issue here is claim construction. Therefore, the court finds *In re Schreiber* to be inapposite, at least at this procedural juncture. Defendants have cited no authority that actually supports their argument that the court should entirely disregard these claim limitations. In any event, the parties discuss these limitations only insofar as they are pertinent to construing the language of the preamble. They do not ask the court to construe these limitations beyond what is already stated in the claim elements. The court will accordingly limit its discussion of this issue to the parties' arguments.

Significantly, the analogous element of claim 1 (claim element 1(f)) claims a controllable valved closure whereby the slit in the thin membrane functions "to provide an opening through said thin membrane *when suction is applied* to said thin membrane and reseal, as a result of said thin membrane being biased to its manufactured position, *when suction is removed* from said thin membrane. " '347 patent, col. 3, ll. 53-58 (emphasis added). The presence of a claim element that expressly refers to suction in claim 1, when compared with the absence of such an express referral in claim 7, suggests that claim 7 was not intended to be limited to a suction-controlled valve. *See Innova/Pure Water, Inc. v. Safari Water Filtration Sys., Inc.*, 381 F.3d 1111, 1119 (Fed.Cir.2004) ("[W]hen an applicant uses different terms in a claim it is permissible to infer that he [or she] intended his [or her] choice of terms to reflect a differentiation in the meaning of those terms."); *Forest Labs., Inc. v. Abbott Labs.*, 239 F.3d 1305, 1310 (Fed.Cir.2001) ("Where claims use different terms, those differences are presumed to reflect a difference in the scope of the claims.").

Moreover, the written description repeatedly suggests that the valve may be operated by a "partial vacuum" or "suction" or by being "stressed." '347 patent, col. 1, ll. 38-39 (partial vacuum or suction is used to form an opening); col. 1, ll. 40-41 (opening closes when partial vacuum or suction is released); col. 2, ll. 38-39 (slit remains closed when thin membrane is unstressed); col. 2, ll. 55-57 (slit remains closed unless a partial vacuum or suction is applied to the thin membrane); col. 2, ll. 62-63 (when user applies external suction it stresses the thin membrane); col. 2, l. 68 to col. 3, ll. 1-2 (when suction is released the slit recloses). The court certainly cannot say that such a disparity in the terminology used in the written description overcomes the presumption that claim 7 (which claims a valve controlled by negative pressure) is different in scope from claim 1 (which claims a valve controlled by suction). Thus, the court can only conclude that claim 7 is different in scope-albeit perhaps only subtly different-than claim 1.

In sum, then, given the lack of clarity that "suction" is necessarily the exclusive connotation for the term "negative pressure," combined with the fact that claim 1 expressly claims a suction-controlled valve whereas claim 7 does not, and the fact that the specification describes valves that can be operated by a variety of means (suction, a partial vacuum, or by being stressed), the court is unpersuaded that it should limit claim 7 by importing the word "suction" into the preamble. The court could construe the language of the claim limitation "controllable valved closure" further, but it declines to do so because this phrase is relatively self-explanatory and the only further meaningful construction sought by the parties is plaintiff's request to import the word "suction." Because the court finds that such a limitation would be improper, no further claim construction is warranted based on the record currently before the court.

B. Claim Element 7(a): "a substantially planar cover portion conforming in shape to the opened end of said container"

[13] The parties agree that this claim limitation describes the portion of the lid surrounding the spout. Playtex contends that the adjectives "substantially planar" should be construed to mean "substantially flat," rather than "substantially planar." In response, plaintiffs argue that the term "planar" requires no further construction and, alternatively, that if the court defines the term planar, it should be construed to mean "thin in comparison to length and width."

The ordinary meaning of planar is "of or relating to a plane: lying in one plane ... having a flat two-dimensional quality." Webster's, *supra*, at 1730. The relevant definition of "plane," in turn, is "a surface such that the straight line that joins any two of its points lies wholly in that surface: a two-dimensional extent of zero curvature: a surface any intersection of which by a like surface is a straight line." *Id.* The written description is not illuminating. The only reference to the substantially planar cover portion merely states that "[t]he closure 10 is circular in shape, having a substantially planar cover portion and may vary in size depending upon the size of the beverage container 11." '347 patent, col. 2, 11. 5-8. The drawings reflect that the portion of the lid surrounding the spout is essentially flat and corresponds in shape to the beverage container.

Ultimately, the court believes that the parties have focused too narrowly on the term "planar." "Planar" does not stand alone in claim element 7(a). Rather, claim element 7(a) refers to "a *substantially planar cover portion* conforming in shape to the opened end of said container." (Emphasis added.) The meaning of the term "plane" can fairly be characterized as a flat, two-dimensional surface. FN3 But the meaning of this term is tempered by transformation of the root word "plane" into its adjective form, planar, which the court construes, according to its ordinary meaning, to mean *having a flat, two-dimensional quality*.

FN3. Plaintiffs argue the two-dimensional dictionary definition applies only to surfaces or other two-dimensional structures, not three-dimensional structures like lids and membranes. The dictionary, however, does not state that a planar structure is perfectly flat and two-dimensional. The dictionary uses the term "surface" and "two-dimensional" in defining "plane," but it defines "planar" as "of or relating to a plane ... having a flat two-dimensional quality." Thus, by definition, a "planar" structure need not be perfectly two-dimensional. Rather, it must simply relate to or have a two-dimensional quality about it.

The patent further modifies the term "planar" with the adverb "substantially." "Substantially" is defined as "in a substantial manner: so as to be substantial." Webster's, *supra*, at 2280. "Substantial," in turn, is defined as "consisting of, relating to, sharing the nature of, or constituting substance: existing as or in substance." *Id.* And "substance" is defined as "essential nature ... a fundamental part, quality, or aspect: essential quality or import: the characteristic and essential part." *Id.* at 2279. It is somewhat difficult to draw an ordinary meaning from these definitions because the definition of the adverb "substantially" is two steps away from the definition of the root word "substance." The thesaurus lists the following synonyms for the adverb "substantially": palpably, materially, structurally, largely, thick, in truth, in essence, and on the whole. Bartlett's Roget's Thesaurus 1321 (1996). The common thread between the dictionary definition and the synonyms listed in the thesaurus is various derivatives of the word "essence" such as "essential" and "essentially." Thus, if the court were to construe the term "substantially," it would likely construe it to mean something such as "a manner that constitutes the essential nature," "essentially," or "in essence." Ultimately, these definitions are no more helpful than the term "substantially," and therefore the court finds that the term

"substantially" requires no further construction. FN4

FN4. The court recognizes that the term "substantially" was probably intended, rather than as a meaningful structural limitation, "to prevent avoidance of literal infringement by minor changes that do not cause loss of an invention's benefit." 2 John Gladstone Mill, III, et al., Patent Law Fundamentals s. 14:17, at 14-43 (2d ed., rev.2004).

The court further notes that the "substantially planar cover portion" is relevant to an understanding of other claim elements. Claim element 7(b) claims attachable means, which the court construes infra to be a friction fit between the lid and the beverage container. Claim element 7(c) claims an elongated passageway extending upwardly and outwardly from the "said cover portion," meaning the "substantially planar cover portion" claimed in element 7(a). Given the language of the entire claim which is consistent with the intrinsic record, then, the court construes the phrase "substantially planar cover portion" to mean *a cover portion having a substantially flat, two-dimensional quality*.

C. Claim Element 7(b): structure for performing the recited function of "selectively maintaining said closure in covering relation with said container"

[14] [15] The parties all agree that claim element 7(b) is a "means-plus-function" limitation. Such limitations are permitted by 35 U.S.C. s. 112, para. 6, which "allows a patentee to express a claim limitation by reciting a function to be performed rather than by reciting structure or materials for performing that function." Northrop Grumman Corp. v. Intel Corp., 325 F.3d 1346, 1350 (Fed.Cir.2003). In construing means-plus-function claim limitations, the court must first identify the claimed function using traditional tools of claim construction. Intellectual Prop. Dev., Inc. v. UA-Columbia Cablevision of Westchester, Inc., 336 F.3d 1308, 1319 (Fed.Cir.2003); Omega Eng'g, Inc. v. Raytek Corp., 334 F.3d 1314, 1330 (Fed.Cir.2003). "Then, the court must identify 'the corresponding structure, material, or acts described in the specification.' " Intellectual Prop. Dev., Inc., 336 F.3d at 1319 (quoting 35 U.S.C. s. 112, para. 6); *see also* Omega Eng'g, 334 F.3d at 1330 (noting the court then determines the structure corresponding to the identified function). Here, the parties agree that the recited function is "selectively maintaining said closure in covering relation with said container." They dispute the structure that corresponds to this function.

This court originally held that the patent failed to disclose structure to perform this recited function and therefore this claim was indefinite in scope and consequently invalid. Freeman v. Gerber Prods. Co., 284 F.Supp.2d 1290, 1297 (D.Kan.2003). The court's holding rested on the fact that the structure identified to perform the recited function is disclosed only in Figures 2 and 5, but not in the written specification, and it was the court's understanding of the law that in a means-plus-function limitation the structure identified to perform the recited function must be disclosed in the specification itself. *Id.* at 1295. The Federal Circuit reversed, explaining that "our cases make it clear that patent drawings may be consulted" in determining "whether there is adequate disclosure of structure for performing a function recited in a means-plus-function claim." Freeman v. Gerber Prods. Co., 120 Fed.Appx. 322, 325 (Fed.Cir.2005). The court further explained:

[A]s far as the function "selectively maintaining said closure in covering relation with said container" is concerned, the specification states that "[t]he closure 10 is circular in shape, having a substantially planar cover portion and may vary in size depending upon the size of the beverage container 11." ['347 patent,] col. 2, ll. 5-8. When one looks to the figures referenced in the written specification, it is apparent that the above function is performed by the manner in which the closure (10) fits together with the beverage container (11),

as depicted in Figures 2 and 5....

Thus, in this case, the only structure disclosed in the specification of the '347 patent that is capable of performing the function of "selectively maintaining said closure in covering relation with said container," is the structure disclosed in Figures 2 and 5. That structure consists of the configuration of the closure (10) with the container (11), as represented in Figures 2 and 5....

Id. at 323. The Federal Circuit remanded the case to this court "for further proceedings consistent with this opinion, beginning with construction of the asserted claims." *Id.* at 323.

Defendants now contend that the court should construe the corresponding structure (i.e., the "means") to be limited to the structure depicted in Figures 2 and 5, but they offer no proposed terminology for describing what this structure depicts. Plaintiffs, on the other hand, point out that the Federal Circuit merely reversed this court's finding of indefiniteness and remanded to this court to resolve the issue of claim construction. Plaintiffs state that the court must now resolve the issue of how one skilled in the art would describe the structural configurations depicted in the drawings of the '347 patent. Plaintiffs ask the court to construe the corresponding structure as being a friction fit between the lid and the cup. In Playtex's original brief, Playtex argued that if the court did not find this element to be indefinite, the attachable means should be construed as a friction fit between the lid and the container as depicted in Figures 2 and 5 of the '347 patent.

The court must endeavor to construe this claim element consistent with the Federal Circuit's ruling. The Federal Circuit held that the "structure consists of the configuration of the closure (10) with the container (11), *as represented in Figures 2 and 5.*" *Id.* at 323 (emphasis added).



Figures 2 and 5 reflect that the outer perimeter of the base of the lid extends downward and encircles the beverage container, and that the lid is kept in place by a friction fit between the interior of the base of the lid and the outside of the beverage container. A person skilled in the art of designing closures for beverage containers would understand that the structure that performs the recited function of "selectively maintaining said closure in covering relation with said container" is a friction fit between the lid and the beverage container. Accordingly, the court construes the "means" to be a *friction fit between the lid and the beverage container*.

D. Claim Element 7(c): "an elongated passageway having an outer end, said passageway extending upwardly and outwardly from said cover portion"

[16] Plaintiffs ask the court to construe this language as "a passageway that is longer than it is wide, has an outer (user) end, and extends sufficiently above the top surface of the lid to enable a child to apply suction to the outer end of the passageway." In response, Gerber contends that this limitation uses plain language that requires no interpretation. Playtex argues the court should construe this limitation to mean "a passageway for dispensing the contents of the container that has an outer end and extends upward and outward from the lid." Playtex argues that plaintiff's proposed construction that the passageway "extends

sufficiently above the top surface of the lid to enable a child to apply suction to the outer end of the passageway" is improper because it relates to the proposed use and seeks to insert non-structural limitations.

The court begins with the plain language of the claim limitation. As discussed previously, unlike claim 1, claim 7 is not limited to a suction-controlled valve. Notwithstanding this, claim element 7(d) states that the opening at the outer end of the passageway must be completely contained within the user's mouth during operation. Indeed, this is consistent with the written description, which explains that the opening is to be "completely contained within the user's mouth during operation of the closure." '347 patent, col. 4, ll. 15-17. The written description also states that "[w]hen consumption of the beverage in the beverage container 11 is desired, the spout 12 is inserted into the mouth of a user." Id., col. 2, ll. 60-62. Thus, claim element 7(d) certainly contains a limitation pertaining to the manner in which the closure operates. And this limitation would be consistent with plaintiffs' proposed claim construction of claim element 7(c).

Nonetheless, the court finds no compelling reason why it should import this limitation from claim element 7(d) into claim element 7(c) in order to create a result that would essentially add a structural limitation to claim element 7(c). Claim element 7(c) already contains a limitation that is clearly intended to describe a type of structure that will enable the opening to be contained in the user's mouth during operation of the closure—that is, that the passageway is elongated, extends upwardly and outwardly from the cover, and has an outer end. Thus, claim element 7(c) already describes the passageway in complete structural detail sufficiently to allow one skilled in the art to understand this claim limitation. Accordingly, the court finds that claim element 7(c) does not require the construction sought by plaintiffs, and no other construction is sought on the record currently before the court.

E. Claim Element 7(e): "a thin membrane having attachable means for attaching said thin membrane to an inner surface of said closure, said thin membrane covering said opening in said passageway"

The parties dispute several aspects of this claim element, including: (1) the structure corresponding to the recited function of "attaching said thin membrane to an inner surface of said closure"; (2) construction of the phrase "thin membrane having attachable means"; and (3) construction of the phrase "said thin membrane covering said opening in said passageway."

1. Structure for performing the recited function of "attaching said thin membrane to an inner surface of said closure"

[17] The parties agree that the first clause of this claim is written in means-plus-function format and that the recited function is "attaching the thin membrane to an inner surface of the closure." They dispute the structure disclosed to perform that function. Like claim element 7(b), the court also originally held that claim element 7(e) failed to disclose a structure to perform this recited function and therefore this claim was indefinite in scope and consequently invalid. *Freeman v. Gerber Prods. Co.*, 284 F.Supp.2d 1290, 1297-98 (D.Kan.2003). The court's holding rested on the fact that the structure identified to perform the recited function is disclosed only in Figure 2. In reversing, the Federal Circuit explained:

[A]s far as the function "attaching the thin membrane to an inner surface of the closure" is concerned, the specification explains that "[a]fter the closure 10 is manufactured to the form shown in FIG. 4, the thin membrane 13 is assembled or insert molded into the spout 12." ['347 patent], col. 2, ll. 48-50. Once the closure 10 and membrane 13 are manufactured to the forms depicted in the figures of the '347 patent, the specification explains that the "closed position [of the membrane 13] makes the closure 10, with the beverage container 11 attached, a spill-proof device even if tipped or over-turned." Id., col. 3, l[1]. 4-6.

When one looks to the figures referenced in the written specification, it is apparent that [this] function ... is performed by the manner in which the membrane (13) fits together with the spout (12), as depicted in Figure 2.

Thus, in this case, ... the only structure disclosed in the '347 patent that is capable of performing the function of "attaching the thin membrane to an inner surface of the closure," is the structure disclosed in Figure 2. That structure consists of the configuration of the membrane (13) and the inner spout (12), as represented in Figure 2....

Freeman v. Gerber Prods. Co., 120 Fed.Appx. 322, 323 (Fed.Cir.2005).

Defendants now contend that the court should construe the corresponding structure (i.e., the "means") to be limited to the structure depicted in Figure 2. Plaintiffs argue the court should construe the structure as "a friction fit, press fit, interference fit, or snap fit." In their original *Markman* briefs, plaintiffs argued that the corresponding structure that performs the recited function is "the structure between the outer surface of the membrane and an inner surface of the closure (the lid) that attaches the membrane to the lid and provides sealing engagement between the membrane and the lid." Gerber argued that the structure should be limited to the ledge-and-groove structure shown in Figure 2 that shows how the thin membrane and spout interlock. Playtex described the structure shown in Figure 2 as "grooves in the thin membrane which interlock with ridges on the inside wall of the spout to hold the membrane in place."



Again, the court must endeavor to construe this claim element consistent with the Federal Circuit's ruling. The Federal Circuit ruled that the structure corresponding to the recited function "consists of the configuration of the membrane (13) and the inner spout (12), *as represented in* Figure 2." *Id.* at 323 (emphasis added). Figure 2 reflects that the entire membrane structure (13) consists of a thin membrane with a perpendicular wall around its perimeter which abuts the interior of the spout. This membrane structure is affixed to the interior of the spout by virtue of a groove on the exterior of the wall that interlocks with a ridge on the interior of the spout to form a snap fit. Significantly, Figure 2 illustrates that different structures correspond to the two means-plus-function limitations. As discussed previously, Figure 2 reflects that the lid remains affixed to the beverage container by virtue of a friction fit. In contrast, Figure 2 depicts a different type of fit between the membrane structure and the spout, and the court therefore rejects plaintiff's suggestion that the disclosed structure consists of a friction, press, or interference fit. Figure 2 clearly depicts that an interlocking snap fit is the means that performs the recited function of "attaching the thin membrane to an inner surface of the closure."

Plaintiffs rely on expert declarations in support of their contention that a person of ordinary skill in the art would recognize that the structure is a friction, press, or interference fit. "Although expert testimony and declarations are useful to confirm that the construed meaning is consistent with the denotation ascribed by those in the field of the art, such extrinsic evidence cannot be used to vary the plain language of the patent document." *Omega Eng'g, Inc. v. Raytek Corp.*, 334 F.3d 1314, 1332 (Fed.Cir.2003) (internal citation omitted); *Vitronics Corp. v. Conceptronic, Inc.*, 90 F.3d 1576, 1584 (Fed.Cir.1996) (stating extrinsic

evidence may not be used to vary or contradict the claim language or the import of other parts of the specification). Here, plaintiffs are attempting to use their expert declarations to vary the intrinsic evidence by importing additional terms that do not accurately depict Figure 2. This, the court must reject. *See Omega Eng'g, Inc.*, 334 F.3d at 1332 (stating the court cannot accept expert declarations that attempt to rewrite the patent's specifications). Figure 2 is unambiguous, and therefore plaintiffs' reliance on expert declarations is improper. *See Texas Digital Sys., Inc. v. Telegenix, Inc.*, 308 F.3d 1193, 1212 (Fed.Cir.2002) (reliance on expert testimony would be improper where patent documents are unambiguous), *cert. denied*, 538 U.S. 1058, 123 S.Ct. 2230, 155 L.Ed.2d 1108 (2003); *Vitronics Corp.*, 90 F.3d at 1584 (expert testimony is entitled to no weight where patent documents are unambiguous).

Accordingly, the court construes the "means" for performing this function to be *an interlocking snap fit formed by a groove on the exterior of the wall around the perimeter of the thin membrane which abuts and is affixed to a ridge on the interior of the spout.*

2. "thin membrane having attachable means"

[18] Plaintiffs ask the court to construe the claim limitation "thin membrane" to mean "a thin, flexible piece of material." Plaintiffs and Playtex agree that "membrane" refers to "a flexible piece of material." Gerber correctly points out that this claim element does not merely refer to a thin membrane standing alone; rather, it refers to a "thin membrane *having* attachable means"; therefore, the term thin membrane must be construed in connection with the attachable means; and the court should construe the "thin membrane having attachable means" to be a one-piece elastomer component. Along those same lines, Playtex points out that "it is basic patent law that an element in a figure with only one type of cross-hatching is a single item" and that the somewhat H-shaped structure comprising the "thin membrane having attachable means" is depicted as a single cross-hatched item. Plaintiffs raise separate arguments with respect to the proper claim construction of "thin membrane" and the "attachable means" (discussed in Section E(1), *supra*), and they do not address the significance of the fact that the "thin membrane" is claimed as "*having* attachable means" (emphasis added), except to argue that the "thin membrane" does not consist of the entire contoured valve structure.

a. "thin"

As a threshold matter, the court rejects Playtex's argument that the term "thin" requires any further construction by being construed as "a thickness that ranges from 0.001 to 0.100 inches" as stated in the written description. The written description is relevant to aid in the claim construction analysis to determine if the presumption that claim terms carry their ordinary and customary meaning is rebutted. *ACTV, Inc. v. Walt Disney Co.*, 346 F.3d 1082, 1090-91 (Fed.Cir.2003). This presumption is overcome "where the patentee, acting as his or her own lexicographer, has clearly set forth a definition of the term different from its ordinary and customary meaning." *Id.* at 1091. This occurs "if the inventor has disavowed or disclaimed scope of coverage, by using words or expressions of manifest exclusion or restriction, representing a clear disavowal of claim scope." *Id.*; *accord Teleflex, Inc. v. Ficosa N. Am. Corp.*, 299 F.3d 1313, 1327 (Fed.Cir.2002). Absent such a clear disavowal of claim scope, it is a cardinal sin of claim construction to import limitations from the written description into the claims, *Teleflex, Inc.*, 299 F.3d at 1324, and the court must "give the claim term its full breadth of ordinary meaning as understood by persons skilled in the art," *ACTV, Inc.*, 346 F.3d at 1091.

In this case, the written description lacks an indication that the patentees clearly intended to limit the term "thin" to a thickness ranging from 0.001 to 0.100 inches. It simply states that "[t]he thickness of the thin

membrane 13 *may* range from 0.001 inches to 0.100 inches." *See* '347 patent, col. 2, ll. 11-13 (emphasis added). This is consistent with the claim term, which states that the membrane must be "thin." When a claim term is expressed with such a general descriptive word, the court "ordinarily will not limit the term to a numerical range that may appear in the written description or in other claims." *Renishaw PLC v. Marposs Societa' per Azioni*, 158 F.3d 1243, 1249 (Fed.Cir.1998); *see also* *RF Delaware, Inc. v. Pac. Keystone Techs., Inc.*, 326 F.3d 1255, 1263 (Fed.Cir.2003) (noting a claim term expressed in general descriptive words typically "will not be limited to a numerical range that may appear in the written description as referring to a preferred embodiment or in other, narrower claims"). Therefore, absent evidence of a clear disavowal of claim scope, the court will not import the limitation from the written description into the claim term and construe the term "thin" to a numerically defined thickness. *Cf.* *Modine Mfg. Co. v. U.S. Int'l Trade Comm'n*, 75 F.3d 1545, 1551 (Fed.Cir.1996) (holding claim was limited to a particular numerical range where a broader range was surrendered during prosecution by amendment of the specification). Accordingly, the court declines to construe the term "thin" to be limited to the numerical range stated in the written description.

b. "membrane"

Although plaintiffs and Playtex ask the court to construe the term "membrane" to be a "flexible piece of material," that proposed meaning does not encompass all of the properties of a membrane under the ordinary meaning of the word. "Membrane" is defined as "a thin soft pliable sheet or layer." *See* Webster's, *supra*, at 1408. "Pliable," in turn, means "bending or creasing easily: FLEXIBLE, SUPPLE." *Id.* at 1741. Thus, one of the words that might describe a membrane is "flexible." But that is only one of the qualities of a membrane. In addition, a membrane is also a thin, soft sheet or layer.

c. "having attachable means"

The difficult aspect of construing this entire claim limitation is that the "thin membrane" is described as "having attachable means." "Having" means "something one possesses or which belongs to one: PROPERTY." *Id.* at 1040. Thus, the thin membrane possesses the attachable means or, in other words, one of the properties that belongs to the thin membrane is the attachable means. The thin membrane is not merely defined as "having means for attaching" the thin membrane to the inner surface of the closure, but rather it is defined as "having *attachable* means for attaching said thin membrane to an inner surface of said closure." The relevant definition of "attachable" is "capable of being fastened or added to something." *Id.* at 140. The adjective "attachable" modifies the "means," which is the ridge-and-groove. Thus, a literal reading of the phrase is that the thin membrane possesses (i.e., has the property, meaning "having") the capability of being fastened or added to ("attachable") the groove-and-ridge structure ("means"). That is, the thin membrane does not need to "have" the entire groove-and-ridge structure (the "means"). Indeed, the thin membrane could not "have" the entire groove-and-ridge structure because the groove-and-ridge structure is comprised of the wall with the groove as well as the ridge on the interior of the spout. The thin membrane does not "have" the spout with the ridge. Rather, the fact that the thin membrane must be "attachable" simply means that the thin membrane must have the capability of being fastened or added to the ridge-and-groove structure. In other words, there must be something about the thin membrane that allows it to be added to the ridge-and-groove structure. Thus, the thin membrane must possess a structure by which the thin membrane ties in to the ridge-and-groove structure. This structure is, of course, the wall with the groove. In other words, the thin membrane has, for its part, its part of the "means" (i.e., the ridge-and-groove structure), meaning that the thin membrane has the wall with the groove. This wall with the groove, then, contributes to the entire ridge-and-groove structure. Thus, the phrase "thin membrane having attachable means" means that the thin membrane has the wall with the groove for attaching the thin

membrane to an inner surface of the spout by virtue of the ridge-and-groove structure.

The court rejects the suggestion that the "thin membrane having attachable means" (meaning the thin membrane plus the wall) must necessarily be a one-piece structure. There is nothing about the ordinary meaning of the word "having" that necessarily connotes a one-piece structure. For example, a person can "have" something—perhaps a house—without the person and the house becoming a one-piece structure. Similarly, one component of an object can have yet another component without the two becoming one. For example, a telephone handset might "have" a cord that attaches the handset to the telephone, yet the handset and the cord are two separate structures. Thus, here, the fact that the thin membrane is claimed as "having" the wall means that the thin membrane must possess the wall or that one of the properties of the thin membrane is that it must have a wall around its perimeter. Therefore, a thin membrane without a wall around its perimeter would not satisfy this limitation. That does not mean, however, that the thin membrane and the wall must necessarily be a one-piece structure. Certainly, the drawings depict one embodiment of the invention whereby the thin membrane and the walls appear to be a one-piece structure. But the court can also envision other scenarios where a thin membrane might "have" a wall without the two forming a one-piece structure. The two components could, for example, be fabricated separately and then the thin membrane could be inserted into a groove on the interior of the wall, thus forming an assembled component but not a one-piece structure. Under these circumstances, the thin membrane would "have" a wall, which would satisfy this claim limitation.

This claim construction is consistent with the other intrinsic evidence of record. It is consistent with the manner in which the term "thin membrane" is subsequently used throughout claim 7. Claim element 7(e) goes on to state that the attachable means (meaning the wall with the groove) is for attaching "*said* thin membrane" (meaning the thin membrane itself) to an inner surface of the spout. This same claim element also states that the thin membrane covers the opening in the passageway. Of course, the thin membrane accomplishes this when the wall surrounding its perimeter is affixed to the interior of the spout by the ridge-and-groove structure. Also, claim element 7(f) states that the slit is through "a planar section of *said* thin membrane." As discussed in Section F, *infra*, the court construes the planar section of the thin membrane to mean the section of the thin membrane that has a flat, two-dimensional quality. Thus, according to claim 7 as a whole, the thin membrane must have the wall for attaching the thin membrane to the inner surface of the spout via the ridge-and-groove structure, it must cover the opening in the passageway, and it must also contain a slit that provides the valve opening, but more specifically (according to claim element 7(f)) the slit must be located in a planar section of the thin membrane. In other words, the thin membrane itself may take any of a variety of shapes, but whatever the shape that the thin membrane in its entirety might take, it must have a planar section where the slit must be located.

This claim construction is also consistent with the specification. The written description states that the thin membrane can be attached to the inner surface of the spout in a variety of ways, such as the thin membrane being assembled, insert molded, or "otherwise attached" to the inner surface of the spout. '347 patent, col. 2, 11. 19-23, 49-50. Also, the written description notably states that "[t]he spout 12 is an integral part of the closure," *id.* at 1. 13, but uses no such similar "integral" terminology with respect to the thin membrane and the wall around its perimeter. Also, the "thin membrane" is depicted in the drawings as structure numeral 13. These drawings depict structure numeral 13 as an essentially H-shaped structure. Certainly, this is consistent with the court's understanding of the terminology "thin membrane having attachable means," which is that the thin membrane plus the wall could be, but does not necessarily have to be, a one-piece structure. But the mere fact that the drawings depict a preferred embodiment of the invention does not limit the claim term "thin membrane having attachable means" to this one-piece structure.

As for defendants' additional suggestion that the component should be made in its entirety from an elastomer material, there is nothing in the claim itself that would require such a result. The only basis for this argument is that the written description states that "[t]he thin membrane is indicated as numeral 13 and may be made of formable materials such as Santoprene, Kraton, Neoprene, Latex, or other elastomers or flexible materials." '347 patent, col. 2, ll. 8-11. In short, the only grounds for the argument that the court should define the "thin membrane having attachable means" as a one-piece elastomer component is based on the manner in which structure numeral 13 is depicted in the drawings and the statement in the specification that the thin membrane indicated as numeral 13 may be made of formable materials, elastomers, or flexible materials. As discussed previously, this certainly may represent the preferred embodiment of the invention. But the court will not commit the cardinal sin of claim interpretation and import these limitations from the specification and drawings into the claim because there is no indication that plaintiffs clearly disavowed the broader scope of the ordinary meaning of the claim language itself.

Accordingly, the court construes the term "thin membrane having attachable means" to be *a thin, soft, pliable sheet having a wall around its perimeter*.

3. "said thin membrane covering said opening in said passageway"

[19] Playtex argues that the court should construe "said thin membrane coveringsaid opening in said passageway" to mean that "the thin membrane prevents liquid from flowing from the interior of the container through the opening to the outside (*i.e.*, making the container 'spill-proof')." Plaintiffs did not respond to Playtex's argument on this issue. The phrases "said thin membrane," "said opening," and "said passageway" have antecedent basis and therefore the novelty of this claim element is that it claims a membrane that *covers* the opening *in* the passageway. "Covering" is defined "as covers." Webster's, *supra*, at 525. The relevant definition of "cover," in turn, is "something that is placed over or about another thing." *Id.* at 524. "In" is simply "a functional word to indicate location or position." *Id.* at 1139. The ordinary meaning of these words does not require the court to import a limitation requiring the membrane to make the container spill proof. Certainly, this claim limitation attempts to describe a structure that has that intended function, and if the court needed to construe an ambiguity in the claim this consideration might carry some weight. Absent any such ambiguity, however, the court sees no reason to import the intended function into a structural limitation. Accordingly, the court construes this aspect of claim element 7(e) to mean *said thin membrane being placed over or about the opening in the passageway*.

F. Claim Element 7(f): "a slit through a planar section of said thin membrane, said slit functioning to provide an opening through said thin membrane when an external negative pressure exists and remain closed when internal and external pressures are equal"

[20] Plaintiffs ask the court to construe the language "a slit through a planar section of said thin membrane" as "a slit having edges that provide an opening through the membrane when external suction exists and form an edge-to-edge, in-plane seal when internal and external pressures are equal." Alternatively, plaintiffs ask the court to construe "planar," just as they did with respect to claim element 7(a), as "thin in comparison to length and width." Defendants ask the court to construe "a planar section of said thin membrane" as "a flat section of the thin membrane."

The court begins by focusing on the ordinary meaning of the term "planar." As discussed previously in Section (B), *supra*, the term "planar" means *having a flat, two-dimensional quality*. See *Innova/Pure Water*, 381 F.3d at 1119 ("Unless otherwise compelled, when different claims of a patent use the same language,

we give that language the same effect in each claim."); *Omega Eng'g, Inc. v. Raytek Corp.*, 334 F.3d 1314, 1334 (Fed.Cir.2003) ("[W]e presume, unless otherwise compelled, that the same claim term in the same patent ... carries the same construed meaning."). This construction is consistent with the intrinsic evidence. As discussed previously, claim 7, as a whole, reflects that the entire thin membrane structure must have a wall for attaching the thin membrane to an inner surface of the spout, it must cover the opening in the passageway, and it must contain a slit that functions as the valve opening. Claim element 7(f) refines the nature of the "thin membrane" even further by clarifying that it must have a planar section (i.e., a section that has a flat, two-dimensional quality) and that the slit must be located through that particular section of the thin membrane. Indeed, the patent drawings consistently reflect that the slit is located through the portion of the thin membrane that is essentially flat and two-dimensional.

The prosecution history is perhaps the most relevant intrinsic evidence with respect to the limitation that the slit must be through "a planar section of" said thin membrane. When plaintiffs originally applied for the patent in 1991, claim element 7(f) claimed "a slit through said thin membrane." On June 24, 1992, an examiner with the PTO conducted a telephone interview with Mr. Freeman. During that interview, the examiner requested and received authorization from Mr. Freeman to add the additional language "a planar section of" so that this claim element reads "a slit through *a planar section of* said thin membrane." The examiner interview summary record describes the general nature of what was agreed to during the interview as: "Agreed upon Examiner's Amendment to clearly define over Coy." The Coy patent, like the '347 patent, essentially claims a beverage container lid with a controllable valved closure. The valve claimed in the Coy patent, however, differs from that of the '347 patent. The Coy patent discloses an apex-type valve (see inset) whereby the top of the valve is essentially ovoid in structure. From that point, the valve tapers and converges downward into two sidewalls which, when the valve is closed, meet at the lower edge of the valve. When the valve is opened by applying lip pressure, the two sidewalls separate and the valve opens to dispense the beverage. Thus, the valve opening in the Coy patent is located at the bottom of the valve where the membrane is essentially V-shaped, depicted in the inset above as numeral 14 in Figure 1 of the Coy patent. By comparison, the valve opening in the '347 patent is located where the membrane is planar, *i.e.*, relatively flat. Thus, construing the phrase "a planar section of" to mean "the section of the membrane that has a flat, two-dimensional quality" would distinguish the '347 patent over Coy because it would eliminate the possibility that the slit could be located at the apex of a V-shaped portion of the thin membrane where two sidewalls converge. Absent this limitation, nothing in claim 7 of the '347 patent would prevent the thin membrane from being V-shaped with a slit at its apex that functions as the valve opening. Thus, adding this limitation distinguishes the '347 patent over Coy.

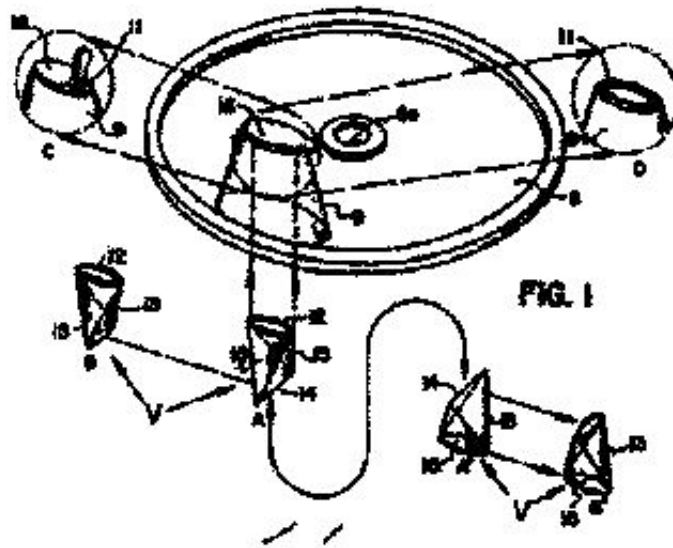

Plaintiffs nonetheless argue that it is not the shape of the membrane that distinguishes the '347 patent over Coy; rather, it is the nature of the seal. Plaintiffs contend that because the seal in the Coy patent is located at the bottom of the V-shaped membrane where the two sidewalls meet, the seal is necessarily an out-of-plane, surface-to-surface seal. In contrast, in the '347 patent the opening is a slit through the membrane and consequently the seal must necessarily be formed by an in-plane, edge-to-edge seal. Although at first blush this argument seems to have some appeal, it is ultimately without merit for the simple reason that the PTO examiner did not choose this language to distinguish the '347 patent over Coy. If the PTO examiner believed that the nature of the seal needed to be clarified in order to distinguish the '347 patent over Coy, then the examiner could have proposed adding language to the original patent application so that the phrase "a slit through said membrane" would have become "a slit through said thin membrane *forming an in-plane, edge-to-edge seal when closed.*" The examiner, however, proposed no such language. Instead, he proposed adding the language "a planar section of." Notably, he did not propose altering the word "through," which is really the aspect of the claim limitation that provides a colorable argument for plaintiff's proposed interpretation. That is, the fact that the slit is "through" the membrane suggests that the seal may very well be formed by an in-plane, edge-to-edge seal. But the terminology "in-plane, edge-to-edge seal" appears nowhere in the intrinsic record. Plaintiffs *only* argument that the court should include this claim limitation is based on the examiner amendment inserting the words "a planar section of" to clearly define the '347 patent over Coy. This amendment, however, addressed the location in the membrane where the slit is located, not the type of seal. Thus, the court is unable to find support for plaintiffs' argument that the court should read such a structural limitation into the claim.

Accordingly, the court construes the phrase "a slit through a planar section of said thin membrane" to be *a slit through the section of the thin membrane that has a flat, two-dimensional quality.* FN5

FN5. The court notes that this claim construction is somewhat different from, but nonetheless relatively consistent with, the manner in which this phrase was construed by another judge of this court. *See Freeman v. The First Years, Inc.*, Case No. 99-2058-KHV, slip. op. at 9-10 (D.Kan. Nov. 22, 1999) (construing the phrase "planar section of said thin membrane" to mean that "*the membrane is held in a fixed plane through means which attach it to the inner surface of the spout*"). The two claim constructions effectively differ in the sense that Judge Vratil construed the limitation to require the membrane to be held "in a fixed plane,"

whereas here the court is construing the limitation "a planar section of" to refer to the portion of the thin membrane that "has a flat, two-dimensional quality." The court believes that the latter construction is more appropriate because requiring a "fixed plane" would derive from the ordinary meaning of the root word "plane" and, as discussed previously, claim 7 notably uses the adjective "planar," which has a slightly different, tempered connotation than the root word "plane."

CLAIM 14

After the PTO issued the '347 patent, it later issued a certificate correcting two lines in claim 14 of the patent. As corrected, claim 14 of the '347 patent reads as follows:

A controllable valved closure for use in dispensing a beverage from a container, said closure comprising:

- (a) a substantially planar cover portion conforming in shape to the opened end of said container;
- (b) attachable means for selectively maintaining said closure in covering relation with said container;
- (c) an elongated passageway having an outer end, said passageway extending upwardly and outwardly from said cover portion;
- (d) an opening in said closure which communicates between the interior and exterior of said passageway;
- (e) a thin membrane having attachable means for attaching said thin membrane to an inner surface of said closure, said thin membrane sealing off said opening in said closure; and
- (f) a disjoined portion within a planar section of said thin membrane, said disjoined portion functioning to provide a flow passage through said thin membrane when said thin membrane is stressed and said disjoined portion forming a seal when said thin membrane is unstressed.

The court construes all of the limitations in claim 14 consistent with the manner in which it construed the analogous limitations in claim 7. The court's analysis with respect to the various limitations of claim 7 applies with equal force to claim 14, differing only in the following respects.

First, with respect to the preamble, plaintiffs' argument that the court should add the word "suction" to describe the controllable valved closure is even less compelling with respect to claim 14 than it is with respect to claim 7. Claim element 14(d) has no limitation that is analogous to the limitation in claim element 7(d) that the opening must be "completely contained in the user's mouth during operation of the closure." Also, whereas claim element 7(f) states that the slit provides an opening in the membrane when "external negative pressure exists," claim element 14(f) states that a disjoined portion in the membrane provides an opening when the membrane is "stressed." Thus, the limitations in claim 14, which are even further afield from connoting the word "suction," certainly do not warrant importing the word "suction" into the preamble of claim 14.

Second, and along those same lines, claim element 14(c) presents an even less compelling case than claim element 7(c) for adopting plaintiffs' proposed limitation that the passageway must "extend[] sufficiently above the top surface of the lid to enable a child to apply suction to the outer end of the passageway."

Unlike claim element 7(d), claim element 14(d) does not state that the opening at the outer end of the passageway must be completely contained within the user's mouth during operation.

[21] Lastly, claim element 14(f) is materially different than claim element 7(f). Plaintiffs ask the court to construe the limitation "a disjointed portion within a planar section of said thin membrane" to mean "a slit, multiple slits, a variety of geometric shapes, or a number of punctured holes having edges that provide an opening through the membrane when the membrane is stressed and form an edge-to-edge, in-plane seal when the membrane is unstressed." Gerber, pointing to the language contained in the specification, contends that "disjointed portion" could constitute a slit, multiple slits, a variety of geometric shapes such as a figure 'H,' a curved line, or a plurality of punctured holes. Playtex states that it agrees with plaintiffs that the term "disjointed portion" means "a slit, multiple slits, a variety of geometric shapes, or a number of punctured holes." Defendants further contend that the edge-to-edge, in-plane seal limitation sought by plaintiffs is improper for the same reasons explained above with respect to claim element 7(f).

"Disjoin" means "to bring an end to the joining of: SEPARATE, DISUNITE, PART, SUNDER ...: to become detached: SEPARATE, PART." Webster's, supra, at 651. Thus, the relevant meaning of "disjointed" means being separated, detached, or parted. The specification explains that the term "disjointed portion" is an alternative to a "slit" such as the one claimed in claim 7: "Slit 14 ... could be multiple slits and/or a variety of geometric shapes such as a figure 'H,' a curved line, etc." '347 patent, col. 2, ll. 30-33. Alternatively, the thin membrane contains "a plurality of punctured holes 16" as depicted in Figure 6. Id. at 11. 39-42.

"[T]he patentee's choice of preferred embodiments can shed light on the intended scope of the claims." *Astrazeneca AB, Aktiebolaget Hassle, KBI-E, Inc. v. Mutual Pharm. Co.*, 384 F.3d 1333, 1340 (Fed.Cir.2004). The scope of the claim, however, is not limited to the preferred embodiments described in the specification. *Fuji Photo Film Co. v. Int'l Trade Comm'n*, 386 F.3d 1095, 1106 (Fed.Cir.2004). A slit, multiple slits, variety of geometric shapes, or a number of punctured holes is consistent with being disjointed (meaning detached, separated, or parted) and to that extent the specification sheds light on the claim. No evidence exists in the written specification, however, that plaintiffs clearly and unambiguously disavowed other ways that the invention might embody the term "disjointed." Rather, the terms slit, multiple slits, variety of geometric shapes, and/or punctured holes are simply alternative preferred embodiments or examples of how the planar section of the thin membrane might be "disjointed." The court declines to limit the claimed invention to the specific examples listed in the specification rather than simply using the ordinary meaning of the term "disjointed." *See Innova/Pure Water, Inc. v. Safari Water Filtration Sys., Inc.*, 381 F.3d 1111, 1117 (Fed.Cir.2004) ("[P]articular embodiments appearing in the written description will not be used to limit claim language that has broader effect."); *Comark Communications, Inc. v. Harris Corp.*, 156 F.3d 1182, 1186 (Fed.Cir.1998) (cautioning against limiting the claimed invention to preferred or specific embodiments or examples in the specification).

Plaintiffs also ask the court to construe this claim element to limit the invention to one that provides an opening through the membrane when the membrane is stressed and forms an edge-to-edge, in-plane seal when the membrane is unstressed. As explained previously with respect to claim element 7(f), the patent examiner did not import such a limitation into claim element 14(f) in order to distinguish claim 14 over Coy. This claim element originally read "a disjointed portion within said thin membrane" and after correction it reads "a disjointed portion within *a planar section of* said thin membrane." This amendment merely clarified that the disjointed portion must be located within a section of the thin membrane that is relatively flat and two-dimensional. Claim element 14(f) presents an even less compelling case than claim element 7(f) for importing plaintiff's proposed "edge-to-edge, in-plane seal" limitation. Whereas claim element 7(f)

claimed a slit "through" a planar section of the valve, claim element 14(f) claims a disjoined portion "within" a planar section of the valve. As discussed previously, the fact that the slit must be "through" the thin membrane suggests that the slit might form an in-plane, edge-to-edge seal when the slit is closed. In contrast, a disjoined portion "within" rather than "through" the thin membrane lends even less support for the argument the disjoined portion in the thin membrane must form an edge-to-edge, in-plane seal. Thus, as with claim element 7(f), the court declines to import any such limitation into claim element 14(f).

In sum, the court could construe the disputed language of the claim limitation further, but it declines to do so because the court finds that the term "disjoined" is relatively self-explanatory and the only further meaningful construction sought by the parties is unwarranted. Limiting the term "disjoined" to the alternative preferred embodiments or examples stated in the written specification would be improper, and plaintiffs' argument regarding the in-plane, edge-to-edge seal is unsupported by the intrinsic evidence of record. Because the court finds that such a limitation would be improper, then, no further claim construction is warranted based on the record currently before the court.

CONCLUSION

In summary, the court concludes that the limitations in claims 7 and 14 do not require further claim construction except as follows:

1. the court construes the phrase "substantially planar cover portion" in claim elements 7(a) and 14(a) to mean *a cover portion having a substantially flat, two-dimensional quality*,
2. the court construes the structure for performing the recited function of "selectively maintaining said closure in covering relation with said container" in claim elements 7(b) and 14(b) to be *a friction fit between the lid and the beverage container*;
3. the court construes the structure for performing the recited function of "attaching the thin membrane to an inner surface of the closure" in claim elements 7(e) and 14(e) to be *an interlocking snap fit formed by a groove on the exterior of the wall around the perimeter of the thin membrane which abuts and is affixed to a ridge on the interior of the spout*;
4. the court construes the phrase "thin membrane having attachable means" in claim elements 7(e) and 14(e) to mean *a thin, soft, pliable sheet with a wall around its perimeter*;
5. the court construes the phrase "said thin membrane covering said opening in said passageway" in claim element 7(e) and 14(e) to mean *said thin membrane being placed over or about the opening in the passageway*;
6. the court construes the phrase "a slit through a planar section of said thin membrane" in claim element 7(f) to mean *a slit through the section of the thin membrane that has a flat, two-dimensional quality*; and
7. the court construes the phrase "a disjoined portion within a planar section of said thin membrane" in claim element 14(f) to mean *a disjoined portion within the section of the thin membrane that has a flat, two-dimensional quality*.

IT IS THEREFORE ORDERED BY THE COURT that claims 7 and 14 of the '347 patent have the

meaning and scope set forth above.

D.Kan.,2005.

Freeman v. Gerber Products Co.

Produced by Sans Paper, LLC.