

United States District Court,
D. Delaware.

ADE CORPORATION,
Plaintiff.

v.

KLA-TENCOR CORPORATION,
Defendant.

Civil Action No. 00-892-(MPT)

Aug. 8, 2002.

William J. Marsden, Jr., Esquire, Thomas L. Halkowski, Esquire, Fish & Richardson P.C, Wilmington, DE, of counsel Robert E. Hillman, Esquire, Craig R. Smith, Esquire, Fish & Richardson P.C, Boston, MA; Howard G. Pollack, Esquire, Kimberly A. Donovan, Esquire, Fish & Richardson P.C, Redwood City, CA, for plaintiff ADE Corporation.

Rudolf E. Hutz, Esquire, Patricia Smink Rogowski, Esquire, Connolly Bove Lodge & Hutz LLP, Wilmington, DE, of counsel Michael H. Kalkstein, Esquire, Chris Scott Graham, Esquire, David C. Bohrer, Esquire, Shawn A. Mangano, Esquire, Oppenheimer Wolff & Donnelly LLP, Palo Alto, CA, for defendant/counterclaimant KLA-Tencor Corporation.

Court-Filed Expert Resumes

MEMORANDUM OPINION

THYNGE, United States Magistrate Judge.

Plaintiff, ADE Corporation ("ADE"), and defendant, KLA-Tencor Corporation ("KLA"), are owners of patents directed to the detection and classification of defects on the surface of silicon wafers as crystalline originated pit ("COP") defects or particle defects. On October 10, 2000, ADE filed this patent infringement suit against KLA alleging infringement of its 6,118,525 patent. D.I. 1. KLA counterclaimed arguing that ADE infringed its 5,883, 710; 6,215,551; 6081,325; and 5,226,118 patents. FN1 Pursuant to *Markman v. Westview Instruments, Inc.*, 52 F.3d 967 (Fed.Cir.1995) (*en banc*), *aff'd*, 517 U.S. 370, 116 S.Ct. 1384, 134 L.Ed.2d 577 (1996); and local practice, this memorandum construes the aforementioned patents and resolves many outstanding pretrial case dispositive summary judgement motions.

THE COURT'S PATENT CLAIM CONSTRUCTION

I. Technology Overview

Directing beams of light at silicon wafers, collecting said light, and attempting to interpret said collected light as a quality tool is not new in the semiconductor industry. The '525, '325, '710, and '551 FN2 patents

involved in this case relate to similar inventions for use in the semiconductor industry for detecting and classifying defects on the surface of silicon wafers as crystalline originate pits ("COPS") or particles. As used in this industry and, in general, the inventions operate by focusing an incident beam of light at the surface of a silicon wafer at an oblique angle to said surface, scanning the surface with said beam, collecting light scattered from said surface, and comparing said scattered light to determine whether the scatter pattern is indicative of a silicon wafer defect (COP or particle).FN3

In contrast to the previous patents, the '118 invention does not physically inspect the surface of silicon wafers searching for defects. Instead, the invention is directed to a system or method that analyzes or processes information previously captured from a physical scan of the surface of a silicon wafer to determine whether the data is representative of a silicon wafer defect. To accomplish this goal, the '118 invention uses predefined or manually manipulated program parameters in conjunction with computer hardware and software to guide system operators during analysis of the raw data previously collected.

II. General Principles of Patent Claim Construction

The parties quibble extensively about the terminology employed to claim the inventions involved in this case. It is difficult to fathom, however, how two very diverging viewpoints can emerge from the same claim language given that officials designated as experts in their respective fields at the United States Patent and Trademark Office studied these inventions and found them patentable. Nonetheless, this court is bestowed with the responsibility of sifting through the parties' arguments to arrive at a claim construction for each of the contested claims. *Markman*, 52 F.3d at 980. In this regard, this court is mindful of the proper weight accorded both intrinsic and extrinsic evidence when performing a *Markman* analysis.

Claim analysis begins with the claim language used to delimit the scope of an invention. *Bell-Atl. Network Servs., Inc. v. Covad Communications Group, Inc.*, 262 F.3d 1258, 1267 (Fed.Cir.2001) (citing *Vitronics Corp. v. Conceptor, Inc.*, 90 F.3d 1576, 1582 (Fed.Cir.1996)); *Renishaw PLC v. Marposs Societa' Per Azioni*, 158 F.3d 1243, 1248 (Fed.Cir.1998); *Bell Communications Research, Inc. v. Vitalink Communications Corp.*, 55 F.3d 615, 620 (Fed.Cir.1995). A court applies to this language an "ordinary and accustomed meaning as understood by one of ordinary skill in the art" at the time the patent was filed. *Hockerson-Halberstadt, Inc. v. Avia Group Int'l, Inc.*, 222 F.3d 951, 955 (Fed.Cir.2000) (citing *Hoechst Celanese Corp. v. BP Chems. Ltd.*, 78 F.3d 1575, 1578 (Fed.Cir.1996); and *Markman*, 52 F.3d at 980); *Schering Corp. v. Amgen Inc.*, 222 F.3d 1347, 1353 (Fed.Cir.2000) (citing *York Prods., Inc. v. Central Tractor Farm & Family Ctr.*, 99 F.3d 1568, 1572 (Fed.Cir.1996)); *Johnson Worldwide Associates, Inc. v. Zebco Corporation*, 175 F.3d 985, 989 (Fed.Cir.1999) (citing *Renishaw*, 158 F.3d at 1249; and *York Prods.*, 99 F.3d at 1568). Claim construction then progresses to a consideration of the remainder of the specification and any prosecution history before the court to determine whether the intrinsic record contains information requiring an interpretation of the words used in the claim differing from that commonly understood by those skilled in the art. *Interactive Gift Express, Inc. v. CompuServe Inc.*, 256 F.3d 1323, 1331 (Fed.Cir.2001) (citing *Vitronics Corp.*, 90 F.3d at 1576-77; *Markman*, 52 F.3d at 979; and *Bell Communications*, 55 F.3d at 620); *see also* *Wang Labs., Inc. v. America Online, Inc.*, 197 F.3d 1377, 1383 (Fed.Cir.1999) (A review of the specification will prevent a court from construing claims to encompass embodiments that are not taught in the specification.); *Southwall Tech. Inc. v. Cardinal IG Co.*, 54 F.3d 1570, 1576 (Fed.Cir.1995) (Arguments and amendments made during prosecution of a patent may be used to exclude a construction that was disclaimed thereby.); and *Elkay MFG. Co. v. Ebco Mfg. Co.*, 192 F.3d 973, 979 (Fed.Cir.1999) (Amendments and arguments made during patent prosecution may result in a forfeiture of certain claim scope).

If the claim words are clear on their face and the intrinsic record contains no indication that the inventors intended anything other than a common art meaning to apply, claim construction ceases without a review of extrinsic evidence. *Interactive Gift*, 231 F.3d at 866; *Hockerson-Halberstadt*, 222 F.3d at 955 (citing *Key Pharms. v. Hereon Labs. Corp.*, 161 F.3d 709, 716 (Fed.Cir.1998)). When the intrinsic record is unclear or ambiguous as to the meaning of claim terms, however, a court may look to extrinsic evidence to discern whether those of ordinary skill in the art attach a meaning to the claim terms eluding the court's grasp due to its unfamiliarity with the technology involved. *Vitronics Corp.*, 90 F.3d at 1583. If so, a court is apt to follow such a construction if that construction is consistent with the intrinsic record, *Id.* Typically, though, extrinsic evidence serves the impassive role of educating the court as to the technology involved because such evidence, unlike the intrinsic record, is ephemeral. *Id.* A court's claim construction, therefore, cannot be dictated by the parties' self-serving motives presented in the crucible of litigation.

Inventors will not be heard to acquire an "after-the-fact" meaning for a claim term based upon extrinsic evidence when exclusionary protection was predicated on fulfillment of statutorily imposed requirements prior to litigation. *North American Vaccine, Inc. v. American Cyanamid Co.*, 7 F.3d 1571, 1577 (Fed.Cir.1993), *cert. denied*, 511 U.S. 1069, 114 S.Ct. 1645, 128 L.Ed.2d 365 (1994) ("after-the-fact testimony is of little weight compared to the clear import of the patent disclosure itself") (citing *Senmed, Inc. v. Richard-Allen medical Indus. Inc.*, 888 F.2d, 815, 819 n. 8, (Fed.Cir.1989)): *see also* *Bell & Howell DMP Co. v. Altek Sys.*, 132 F.3d 701, 706 (Fed.Cir.1997) ("[T]estimony of an attorney 'amounts to no more than legal opinion-it is precisely the process of construction that the court must undertake.' ") (quoting *Markman*, 52 F.3d at 983)). 35 U.S.C. s. 112, para. 1 provides that the patent specification must contain a "full, clear, ... [and] concise" explanation of the invention as claimed in "exact terms as to enable any person skilled in the art to which it pertains, or with which it is most nearly connected, to make and use the same, and shall set forth the best mode contemplated by the inventor of carrying out his invention." 35 U.S.C. s. 112, para. 2 further provides that a patent specification must "concluded with one or more claims particularly pointing out and distinctly claiming the subject matter which the applicant regards as his invention." Simply put, the intrinsic record should contain everything a court needs to determine the bounds of an invention; this record controls the *Markman* inquiry. *Vitronics Corp.*, 90 F.3d at 1583.

III. ADE Corporation's '525 Patent

A. Claim 1FN4

1. [Preamble] "A surface inspection method for distinguishing between particle and pit defects on a surface of a workpiece, said method comprising:"

ADE contends that the preamble of claim 1 should limit the entire claim because it defines the invention. D.I. 318 at 10-11. In support of this allegation, ADE notes that both its expert, Dr. Bullis, and KLA's expert, Dr. Eimerl, agree that the '525 invention lacks meaning if the invention cannot distinguish between particle defects and pit defects. *Id.* KLA argues that the preamble should not be used to limit claim 1 because ADE is attempting to "improperly read[] an 'extremely small' limitation into the phrase 'particle defects and pit defects' " when claim 1 contains no size limit. D.I. 414 at 17.

As a general rule, patent claim preambles do not limit the claims they precede. *DeGeorge v. Bernier*, 768 F.2d 1318, 1322 n. 3 (Fed.Cir.1985)). The general rule is applied, however, on a case-by-case basis against

each preamble at issue to determine whether the inventors intended the preamble to function as a limitation to the claim or merely as a statement of an intended use of the invention. *Applied Materials, Inc. v. Advanced Semiconductor Materials America, Inc.*, 98 F.3d 1563, 1573 (Fed.Cir.1996); *C.R. Bard Inc. v. M3 Sys. Inc.*, 157 F.3d 1340 (Fed.Cir.1998). In the former situation, the preamble constitutes an indispensable component of the invention embodied by the claim and the claim must be construed accordingly. *See Phillips Petroleum Co. v. Huntsman Polymers Corp.*, 157 F.3d 866, 872 (Fed.Cir.1998) ("A term appearing in the preamble is limiting when ... it is found to be required to confer meaning on the claim."); *see also Bell Communications Research, Inc. v. Vitalink Communications Corp.*, 55 F.3d 615, 620 ("[W]hen the claim drafter chooses to use both the preamble and the body to define the subject matter of the claimed invention, the invention so defined, and not some other, is the one the patent protects."). In the latter situation, the preamble is not part of the claimed invention and does not influence the construction of the claim. *Apple Computer, Inc. v. Articulate Sys., Inc.*, 234 F.3d 14, 22 (Fed.Cir.2000) ("Language in a claim preamble ... acts as a claim limitation only when such language serves to 'give meaning to a claim and properly define the invention,' not when the preamble merely states a purpose or intended use of the invention.") (citing *In re Paulsen*, 30 F.3d 1475, 1479 (Fed.Cir.1994)) (quoting *DeGeorge*, 768 F.2d at 1322 n. 3.).

In this court's opinion, the preamble of claim 1 is most appropriately viewed as a statement of the intended use of the '525 invention. The preamble reads "[a] surface inspection method...." What is the intended use of this method? The preamble answers the question: "... for distinguishing between particle defects and pit defects on a surface of a workpiece." The preamble then concludes with a traditional transitional phrase. Once having read the preamble, the reader's attention is never drawn back to it because the body of the claim does not need to be read in light of the preamble for one of ordinary skill in the art to understand the elements of the claim and how those elements are interrelated.

The '525 specification discloses that the invention "distinguish[es]" between pit and particle defects giving typical size ranges for such defects. A defect size limitation, however, is not provided in claim 1. ADE may be correct in noting that the experts agree that the '525 invention lacks meaning if it cannot distinguish between pit and particle defects. This, though, does not mandate that the preamble of claim 1 of the '525 invention is essential to an understanding of the invention. The elements of claim 1 clearly detail the invention. Claim 1 claims the method of (1) receiving a workpiece, (2) scanning the surface with P-polarized light, (3) collecting light scattered from the workpiece surface, (4) converting the collected light to signals, (5) comparing those signals, (6) to determine whether a defect is one of a pit and a particle. The preamble is not necessary to understand the method claimed or the scope of the invention encompassed thereby.

Accordingly, this court will not read the preamble of claim 1 as a limit to the claim to impart a size limit on the defects detected by the invention where none exists in the body of the claim. The preamble of claim 1 adds nothing to the public notice function of the claim, it merely states an intended use of the invention. This court holds, therefore, that the preamble of claim 1 does not limit the claim.

2. "workpiece"

KLA proposes that a person skilled in the art reading claim 1 would consider "workpiece" to mean a silicon wafer or similar article susceptible to the types of defects the '525 patent was intended to detect. D.I. 344 at 12-13. ADE would have this court construe the word "workpiece" as a silicon wafer or equivalent article with particle and COP defects. D.I. 396 at 1-2. Clearly, the parties' interpretations of "workpiece" are similar. ADE's construction, however, expressly states that "workpiece" refers to articles with particle and

COP defects; whereas, KLA's downgrades the importance of the presence of COP defects on the surface of the "workpiece."

Surely, the word "workpiece" conjures up the notion that something is being acted upon. In the case of claim 1 of the '525 patent, the thing doing the acting is a beam of Ppolarized light. The word "workpiece," however, is broad in that it may encompass almost any article. One must, therefore, check the context in which the word is used to determine what the inventors meant. In claim 1, it is evident that "workpiece" refers to an item susceptible to particle and pit defects because the presence of such is being determined in the last step of the method claimed. Although the meaning intended by the inventors becomes clearer with reference to the context, particle and pit defects may also have a broad meaning. Thus, the word "workpiece" may still mean many things. In this event, a person of ordinary skill in the art would look to the '525 written disclosure to determine what the inventors intended by using the word "workpiece" to define their invention.

On numerous occasions, pit and COP defects are mentioned in the written description of the '525 patent in the same breath. It is clear that these words are interchangeable. For example, the disclosure provides that "if the defects are pits or 'COPS' (crystal originated pits) in the wafer surface, they are not removed by recleaning." '525 at 1:25-30. A person of ordinary skill in the art would readily understand that a pit as used in claim 1 refers to a COP defect. This, however, does not end the inquiry. One must also discover what type of "workpiece[s]" contain COP and particle defects. The inventors specify that "[t]he present invention relates to surface inspection systems and methods and, more particularly, to the inspection of articles or workpieces, such as silicon wafers" '525 at 1:15-18. Later, in the description of the preferred embodiment, the inventors specify that Figure 1, provided below, represents "a surface inspection system 20 for detecting defects such as particles, pits and the like on a surface of a workpiece W or article, such as a silicon wafer."

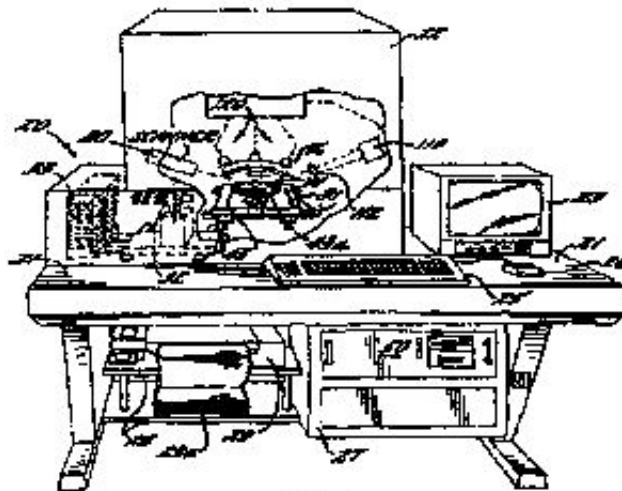

FIG. 1

The '525 patent unquestionably discloses an invention capable of detecting the presence of particle and COP defects on the surface of silicon wafers. Although the inventors do not specifically state in claim 1 that the "pits" referred to on the surface of the "workpiece" are COPS, that meaning was clearly intended. To hold

oppositely would require inventors to turn patent claims into catalogues of lexicons. This court refuses to render such a holding when the written disclosure establishes the meaning of the words used in the claim. In as much as KLA implicitly attempts to construe "workpiece" so that a "pit" is not a "COP," this court disagrees. Such an interpretation would be inconsistent with the purpose of the '525 patent and is improper. *See Hockerson-Halberstadt, Inc. v. Avia Group Int'l, Inc.*, 222 F.3d 951, 956 (Fed.Cir.2000) (citing *Renishaw PLC*, 158 f.3d at 1250). Accordingly, the word "workpiece" is construed to mean a silicon wafer or similar article susceptible to particle and COP defects.

3. "scanning the surface of the workpiece"

ADE asserts that "scanning the surface of the workpiece" is a commonly understood practice in the silicon wafer inspection industry. D.I. 318 at 11. As used, ADE contends that the phrase encompasses relative movement between the surface scanned and the incident beam of P-polarized light such that the entire surface is inspected. *Id.* ADE further argues that the '525 written disclosure teaches many different ways of "scanning the surface of the workpiece" such as through translation or rotation of the workpiece or movement of the beam of P-polarized light. *Id.* KLA attempts to limit "scanning the surface of the workpiece" to a deflection of the beam of P-polarized light across the surface of the workpiece in a relatively narrow scan path. D.I. 344 13-20. Furthermore, KLA asserts, this proposed construction is different from one that permits the workpiece to be translated or rotated during a scan. *Id.*

This court is not inclined, as KLA suggest, to limit "scanning the surface of the workpiece" to "scanning" along a relatively narrow scan path without also encompassing other relative movement between the workpiece and directed beam of P-polarized light. "Scanning" is a broad term, similar to "workpiece," that brings to mind many different concepts. The context in which the word is used in the claim, though, is not helpful because it does not indicate how "scanning" is accomplished. One skilled in the art, therefore, must turn to the remainder of the intrinsic record to determine what the inventors intended.

The '525 disclosure teaches several ways to perform a surface scan of a workpiece. '525 at5:15-7:5. During some of these scans, the workpiece is translated and rotated along its material path as it is inspected. *Id.* Figures 2 and 5, reproduced below, support translation and rotation of the workpiece during scanning.

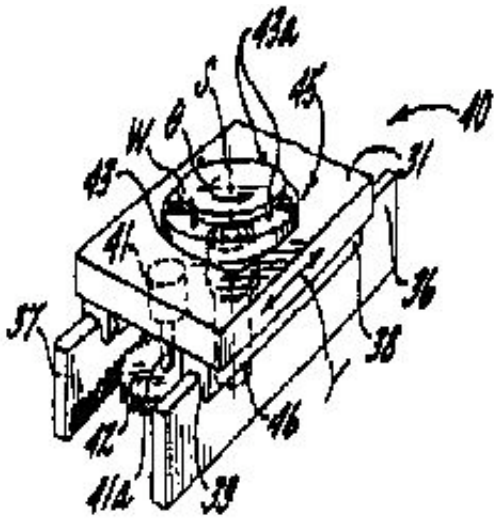

FIG. 2

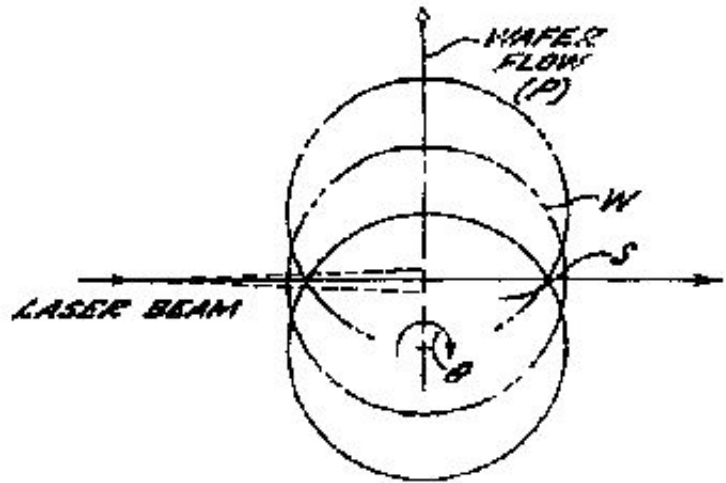

FIG. 5

One skilled in the art would recognize in Figure 2 that the curved arrow in the center of the silicon wafer with the Greek symbol (θ) attached thereto represents that the wafer (or workpiece) is undergoing rotation. Again, in Figure 5 this can be seen, however, Figure 5 also depicts a translation of the wafer (WAFER FLOW) during a scan by the beam of P-polarized light (LASER BEAM).

Claim 1 of the '525 patent does not limit "scanning" to any particular type of scan; instead, the claim plainly states that one step in the disclosed inspection method is to scan the surface of the workpiece at the inspection station. '525 at 12:19-25. In contrast, KLA would have this court read a non-existent limitation into the phrase "scanning the surface of the workpiece" from dependent claim 21. D.I. 344 at 13-20. 35 U.S.C. s. 112, para. 4 does contain the requirement that a dependent claim further narrow the independent claim from which it depends. Dependent claim 21, however, fulfills this requirement.

Simply because dependent claim 21 explicitly provides that the workpiece is translated and rotated during the surface scan does not raise the negative limitation that "scanning" in claim 1 excludes this possibility. ('525 14:17-22) *See Marsh-McBirney, Inc. v. Montedoro-Whitney Corp.*, 882 F.2d 498, 504 (Fed.Cir.1989) ("[N]arrow claim limitations cannot be read into broad [claims] whether to avoid invalidity or to escape infringement.") (quoting *Uniroyal Inc. v. Rudkin-Wiley Corp.*, 837 F.2d 1044, 1054 (Fed.Cir.1988)). Thus, the presence of a limitation to "scanning" in dependent claim 21 does not prevent the broad word "scanning" in independent claim 1 from encompassing other relative movement between the workpiece and the beam of P-polarized light. Some movement must exist between the light beam and the surface to inspect the entire surface "scanned" and effectuate the inventors' invention. Claim 1 of the '525 patent ensnares all such movement whereas dependent claim 21 specifies that the movement is translation and rotation. Any other construction is simply illogical and inconsistent with the invention taught in the '525 patent.

KLA, however, points to the fact that the written description describes the beam of P-polarized light as "narrow" and attempts, therefrom, to read this limitation into the word "scanning" in claim 1. Patent claims define and limit the invention. Claim 1 does not limit "scanning" to a narrow scan path. This court will not read such a limitation into the claim. Since a clear meaning of "scanning the surface of the workpiece" is readily ascertainable from the written description, no extrinsic evidence need be considered. *Interactive Gift*,

231 F.3d at 866; Hockerson-Halberstadt, 222 F.3d at 955 (citing Key Pharms., 161 F.3d at 716). This court, therefore, construes "scanning the surface of the workpiece" to mean that the entire surface of the workpiece is inspected through relative motion of the incident beam of P-polarized light and/or the workpiece being inspected.

4. "signals representative of light scattered into said zones"

ADE maintains that "signals" includes any signal representative of or corresponding to scattered light. D.I. 318 at 21. KLA argues for an ordinary meaning, but does not specify one. D.I. 344 at 34. ADE's construction of "signals" is consistent with the written description portion of the '525 patent. '525 at 7:54-60 ("The determining means of the collector ... which receives signals representative of collected light from the light channel detector 110 and the dark channel detector 120."). This court, therefore, holds that "signals" includes any signal representative of or corresponding to scattered light.

5. "comparing said signals"

KLA argues for the first time in its responsive claim construction brief that "comparing said signals" should be construed to exclude the operation of normalization and subtraction. D.I. 414 at 30. ADE does not state a proposed meaning.

In support of its construction, KLA quotes a paragraph from a statement made by the inventors during patent prosecution: "Neither of the references teaches or suggest comparing scattered light intensities in different angular locations. As discussed above, Quackenbos FN5 normalizes and subtracts the signals from the two sensors 28 and 48 but does not compare the levels of the signals...." Id. From that snippet of information, KLA asks this court to exclude entirely the operations of normalization and subtraction from the scope of the ' 525 patent when signals are compared.

This court declines to do so. KLA has taken the quoted language out of context. The inventors merely stated that Quackenbos "normalizes and subtracts ... but does not compare the levels of the signals." Id. Viewed in this fashion, it is clear that the inventors were not attempting to surrender the functions of normalization and subtraction but, instead, were distinguishing their own invention by arguing that Quackenbos only "normalizes and subtracts" and does not also "compare the levels of the signals." Therefore, this court will not construe the phrase "comparing said signals" to exclude the functions of normalization and subtraction.

B. Claim 7 FN6, Claim 8 FN7, and Claim 9FN8

1. "signals are representative of intensities of the light," "signals represent light intensities," and "intensity signal"

KLA maintains that dependent claims 7, 8, and 9 should be construed according to their ordinary meaning. D.I. 344 at 38. ADE argues that the phrases "signals are representative of intensities of the light", "signals represent light intensities, and "intensity signal" include any signal indicative of the intensity of the scattered light emitted from the surface of the silicon wafer during scanning. D.I. 318 at 23. ADE's proposed interpretation of the aforementioned phrases in Claims 7, 8, and 9 is consistent with the written description portion of the '525 patent. '525 at 7:54-60 ("The determining means of the collector ... which receives signals representative of collected light from the light channel detector 110 and the dark channel detector 120."). This court, therefore, holds that these contested phrases include any signal indicative of the intensity of the scattered light emitted from the surface of the silicon wafer during scanning.

C. Claim 19 FN9 and Claim 20FN10

1. "sorting" and "classifying"

ADE argues that the words "sorting" and "classifying" as used in the '525 patent have an ordinary meaning in the art. ADE further asserts that one of ordinary skill in the art would recognize that the '525 patent teaches "sorting" and "classifying" of defects on the surface of silicon wafers according to pre-selected criteria or "recipe[s]". D.I. 318 at 24. KLA contours this construction by arguing that the '525 patent does not disclose any pre selected criteria or "recipe" for "sorting" and "classifying" defects, therefore, the claims are invalid under 35 U.S.C. s. 112, para. 1 because the inventors were not in possession of the invention claimed at the time of filing. D.I. 414 at 33-34. At the very least, KLA asserts, the two words should be construed to mean that defect organization is conducted by the operator based upon certain criteria. Id.

This court agrees with KLA that the written description of the '525 patent does not contain a "recipe" for "sorting" and "classifying" defects, but this court cannot extend such reasoning to a holding that dependent claims 19 and 20 are invalid under 35 U.S.C. s. 112, para. 1 because the inventor lacked possession of the invention at the time of filing. Dependent claims 19 and 20 do not contain the word "recipe." An inventor need not be in possession of something that is unclaimed.

Dependent claims 19 and 20 use the word "sorting" and "classifying." These words have a common meaning in everyday language. Nothing in the specification or prosecution history indicates that the inventors intended any other meaning to apply. According to *Webster's II New Riverside University Dictionary*. 1988, "classifying" means "to organize or arrange according to class or category." Id. at 268. In this same dictionary, "sorting" means to "arrange according to class, kind, or size." Id. at 1110. Consistent with these definitions and the teachings of the '525 patent, this court holds that "classifying" means to "organize or arrange" pit and particle defects according to "class or category." Similarly, "sorting" as used in the '525 patent means to arrange pit and particle defects "according to class, kind, or size."

D. "central zone" and "second oblique zone offset angularly from said first zone" of Claim 1, "central zone includes a scattering direction substantially perpendicular to the surface" of Claim 4 FN11, "offset at least forwardly of said first zone" of Claim 2 FN12, and "offset at least backwardly of said first zone" of Claim 5FN13

The aforementioned contested claim terminology is intertwined. The parties' arguments as to each and claim construction for each is, therefore, addressed jointly in this section by first summarizing the parties' arguments and then performing a single analysis combining claim construction for each of the contested phrases.

1. "second oblique zone offset angularly from said first zone"

ADE contends that the entire phrase "second oblique zone offset angularly from said first zone" as used in claim 1 of the '525 patent is disputed. D.I. 318 at 15. KLA asserts that the phrase "oblique zone" and "offset angularly" are contested. D.I. 344 at 22, 31. Although conceivable, it is unlikely that disposition of this case is affected by whether the entire phrase or the individual sub-phrases are construed because both parties' arguments center on the same underlying issues.

ADE is asserting that "second oblique zone offset angularly from said first zone" in claim 1 of the '525

patent refers to a light collection zone differing in polar angle from the central zone mentioned in the same claim. D.I. 318 at 16-20. Moreover, ADE asserts, the "second oblique zone" is not limited in placement by any particular azimuthal angle but, instead, may be placed at any azimuthal angle circling a surface normal centrally located on the surface of the article being inspected because claim 1 does not limit placement of this zone within any azimuthal range. Id.

KLA maintains that ADE's proposed meaning of "second oblique zone offset angularly from said first zone" is egregious contending that "oblique zone" and "offset angularly" mean that a second light collection apparatus is placed in the plane of incidence either forward or backward of the "central zone" mentioned in the same claim and that this zone is incapable of simultaneously collecting light with the "central zone;" therefore, it must collect light separately either forward or backward of this zone. D.I. 344 at 22-29, 31-34.

2. "central zone" of Claim 1, "central zone includes a scattering direction substantially perpendicular to the surface" of Claim 4, "offset at least forwardly of said first zone" of Claim 2, and "offset at least backwardly of said first zone" of Claim 5

ADE argues that "central zone" has an ordinary and plain meaning in the semiconductor wafer inspection industry. D.I. 318 at 13-15. According to ADE, those skilled in the art would recognize that "central zone" refers to a centralized area above the center of the workpiece surface that may include a direction precisely normal to the surface of the workpiece, but need not necessarily. Id. Thus, ADE contends, "central zone" means a centralized area above the workpiece surface positioned to capture light generally scattered in the normal direction. Id. In support of this position, ADE notes that nothing in the specification of the '525 patent or its prosecution history conveys that the inventors intended a special art meaning for this phrase. Id.

KLA argues that the phrase "central zone" implies collection of scattered light in at least the normal direction and that the phrase does not have an ordinary and plain meaning in the art. D.I. 344 at 29-31; D.I. 414 at 26-29. In support of this argument, KLA points to the fact that the phrase was added almost two years into the prosecution of the '525 patent (for purposes of litigation), is not used anywhere in the written description, and ADE is unable to find a single extrinsic source defining the phrase including previous works of the inventors. Id.

In a related argument, KLA maintains that dependent claim 4 ("central zone includes a scattering direction substantially perpendicular to the surface") is invalid under 35 U.S.C. s. 112, para. 4 as failing to further limit the claim upon which it depends (claim 1 of the '525 patent). Similarly, KLA argues, claim 2 ("offset at least forwardly of said first zone") and claim 5 ("offset at least backwardly of said first zone") are invalid under 35 U.S.C. s. 112, para. 1 and 4.

3. Analysis

The phrases "central zone" and "second oblique zone offset angularly from said first zone" lie at the heart of this controversy. Analysis of each phrase, as is construction of the contested phrases from claims 4, 2, and 5, are hinged upon each other and combined here for convenience. Before proceeding, though, it should be noted that a court can construe claim terminology to have a common English meaning, a common art meaning, a specific art meaning, a specific inventor imposed meaning, or, inevitably, no discernable meaning. The court has five choices or, put another way, inventors have five ways to claim their inventions in accordance with 35 U.S.C. s. 112 so that the public can confidently understand the invention and attempt to invent around it.

It is rudimentary patent law that inventors may be their own lexicographers. *ZMI Corp. v. Cardia Resuscitator Corp.*, 844 F.2d 1576 (Fed.Cir.1998); *Fonar Corp. v. Johnson & Johnson*. 821 F.2d 627 (Fed.Cir.1987); *Loctite Corp. v. Ultraseal Ltd.*, 781 F.2d 861 (Fed.Cir.1985); *Fromson v. Advance Offset Plate, Inc.*, 720 F.2d 1565 (Fed.Cir.1983). Having assumed such a responsibility, however, an inventor further assumes the responsibility of explaining that terminology in the intrinsic record so that others are well apprised of that which the inventor regards as his or her invention. *Constant v. Advanced Micro Devices, Inc.*, 848 F.2d 1560 (Fed.Cir.1988); *Intellicall, Inc. v. Phonometrics, Inc.*, 952 F.2d 1384 (Fed.Cir.1992) Otherwise, the words are given an ordinary meaning. *Kegel Co. v. AMF Bowling, Inc.*, 127 F.3d 1420 (Fed.Cir.1997).

The phrases "central zone" and "second oblique zone" do not appear anywhere in the written description or drawings of the '525 patent. They appear first in the prosecution history after being added almost two years into prosecution, but no explanation as the meaning of these phrases is found in the prosecution history. ADE argues, however, that the inventors did not intend a specific meaning for the phrases and that those skilled in the art would readily comprehend what is meant. D.I. 318 at 13-20. ADE, though, is unable to direct this court's attention to any reference in the art using these exact terms including the inventors' own publications. Instead, ADE relies on the dictionary definition of the modifying words "central" and "oblique" to grant an overall meaning to the phrases "central zone" and "oblique zone." *Id.*

KLA request this court to construe "central zone" and "oblique zone" such that the '525 invention collects scattered light separately in forward, backward, and central collection locations within the plane of incidence formed by the beam of P-polarized light and the surface being scanned. Reading a "plane of incidence" limitation into claim 1 where none exists, however, constitutes reversible error. *Tate Access Floors, Inc. v. Maxcess Technologies, Inc.*, 222 F.3d 958, 966 (Fed.Cir.2000) ("[I]t is improper to read limitations [explicit or implicit] from the written description into a claim.") (citing *Kemco Sales, Inc. v. Control Papers Co.*, 208 F.3d 1352, 1362 (Fed.Cir.2000)). Furthermore, inventors need not achieve one-to-one correlation between claim language and the written description or drawings. This court, therefore, is not inclined to whole-heartedly adopt KLA's proposed construction.

The '525 disclosure teaches that the inspection system possess more than one light collection apparatus designed to collect light separately as exemplified by Figures 3 and 6, reproduced below, of the patent where collectors 121, 123, and 125 focus scattered light onto dark channel detectors 122, 124, and 126. Three distinct groupings of light collectors (121, 123, and 125) focus light onto three different dark channel detectors (122, 124, and 126) to produce three separate signals in the preferred embodiment for use in distinguishing between pit and particle defects. '525 at 7:5-60.

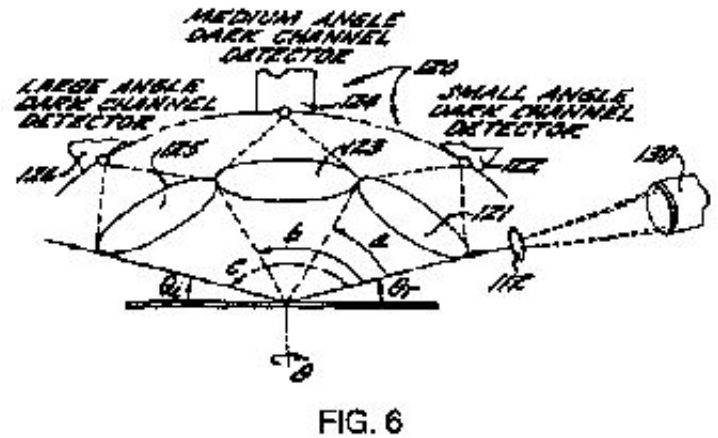
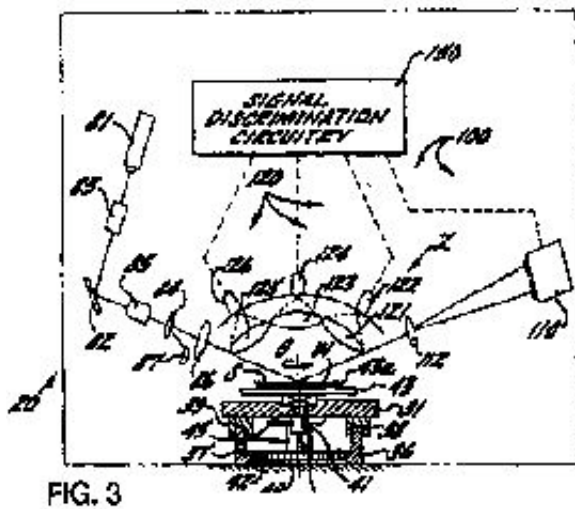

Placement of these collectors is not specifically limited in number or to any range of azimuthal angles in the '525 written description. Consistent with the internal logical of the '525 specification, however, the detection apparatus embodied in the 525 patent utilizes separate collection of forward, central, and backward scattered light and teaches that placement of the three collectors (121, 123, and 125) in Figure 6 is determined with respect to the angle of refraction, θ_r , of the beam of P-polarized light as depicted in Figure 6 by angles a, b, and c and described in the written description:

The light which is scattered from the workpiece surface is collected as separate light components at different angles. For example, light components scattered substantially normal from the surface ... and light components scattered substantially normal from the surface ... are separately collected and compared to thereby ascertain differences in the angular distribution of the scattered light. Light scattered from the surface ... is separately collected by a plurality of collectors 121, 123, 125 at a plurality of predetermined scattering angles a, b, c. Preferably, the collectors are positioned to collect forwardly scattered light components, backwardly scattered light components, and light components scattered in a direction substantially perpendicular to the surface of the workpiece.

'525 at 9:25-39.

The prosecution history of the '525 patent also supports the separate collection of forward, central, and backward scattered light as an integral component of the claimed invention. To an office action mailed June 5, 1998, the inventors filed a response on August 18, 1998 distinguishing their invention from two prior art references. KLA's Appendix in Support of Opening Claim Construction Brief Regarding ADE's 525 Patent at 309-317. Central to their argument was the fact that the '525 patent, unlike the prior art references, separately collects scattered light in the forward, central, and backward scatter regions for comparison of the intensities and a determination of the presence of pit and particle defects. *Id.*

This court is well aware, as ADE manifestly argues, that a preferred embodiment does not, necessarily, define the claimed invention as detailed by the language of the claims. In the case at bar where the inventors have failed to adequately provide in the written description for the meaning of the terms employed to claim their invention (i.e. the phrases "central zone" and "second oblique zone"), however, a preferred embodiment as well as statements made by the inventors during prosecution assume heightened status that cannot be ignored even though claim terms taken out of context broadly encompass a conceivably different invention.

See Intel Corp. v. Broadcom Corp., 172 F.Supp.2d 515, 545 (D.Del.2001) (McKelvie, J.) (citing *Wang Labs., Inc. v. America Online, Inc.*, 197 F.3d 1377 (Fed.Cir.1999)) ("[P]atent claims should not be construed to cover embodiments that are not supported by the specification and are contradicted by the prosecution history."); *see also Digital Biometrics, Inc. v. Identix, Inc.*, 149 F.3d 1335, 1347 (Fed.Cir.1998) (A patentee's global assertions made without regard to any particular claims and used to distinguish prior art can operate as a surrender of claim scope.). A claim is to be construed consistently with that commonly understood by those skilled in the art at the time the patent was filed. When a claim term is not commonly understood in the art, not fully explained in the written description or prosecution history, and extrinsic evidence is useless, those skilled in the art are left with little more than preferred embodiments and prosecution history from which to glean a modest concept of the scope of an inventors' invention.

This being so, this court is compelled to find consistent with the written description and prosecution history of the '525 patent and hold that "central zone" means a light collecting zone positioned to collect light generally scattered in the normal direction and, "second oblique zone" means a second collection zone differing in polar angle from the central collection zone that does not collect the same light being collected by the "central zone" but, instead, collects either forward or backward scattered light but does not collect both simultaneously. Any other interpretation is nonsensical to those skilled in the art and inconsistent with the internal logic of the written description and prosecution history of the '525 patent.

Nonetheless, this court is not of the mind to hold, as KLA desires, that placement of the "second oblique zone" collectors be positioned within the plane of incidence. Although the preferred embodiment depicted in Figures 3 and 6 above tend to indicate such a construction, nothing else within the written description or prosecution history of the '525 mandates such an interpretation. A "plane of incidence" limitation does not exist in claim 1, the claim is written broad enough to encompass placement of a "second oblique zone" in locations outside of the plane of incidence and, therefore, this court will not limit placement of the "second oblique zone" to within the plane of incidence.

This court holds, therefore, that the inventors predicated patentability on separate collection of forward and/or backward scattered light emanating from the surface being scanned in addition to collection of light scattered generally in the normal direction by the "central zone" and so construes the "second oblique zone" element of claim 1 of the '525 patent accordingly. Patentability, however, was not predicated upon a "plane of incidence" limitation (or azimuthal range limitation) and one is not read into claim 1 by this court. Dependent claims 2, 4, and 5, therefore, are valid because they are not inconsistent with this construction of the contested terms in claim 1 of the '525 patent.

IV. KLA-Tencor's '325 Patent

B. Claim 36 FN14 and Claim 43FN15

1. [Preamble] "... detection of anomalies, such as particles or pattern defects ..."

The phrase "... detection of anomalies, such as particles or pattern defects ..." appears in the preamble of claims 36 and 43. '325 at 18:27-28, 66-67. KLA argues that these preamble statements should not limit the claims. D.I. 338 at 13-14. In the event that the court does find these preambles limiting, KLA asserts that the preambles mean that particle, pit, or pattern defects are detected. D.I. 416 at 11-18. ADE argues that these preamble statements limit the claims and should be construed to mean that at least particle and pattern

defects are detected. D.I. 316 at 20-25.

As mentioned, *supra*, preamble statements limit patent claims when necessary to "give meaning to [the] ... claim," not when the preamble merely enunciates upon the intended use of the invention. *Applied Materials.*, 98 F.3d at 1573; *C.R. Bard Inc.*, 157 F.3d at 1340. The preamble of claims 36 and 43 of the '325 patent do not "give meaning" to or otherwise define elements contained in the body of those claims; rather, this language conveys a purpose or intended use for the invention. *Id.* The preamble of claim 36 reads as follows: "An optical system for detection of anomalies, such as particles or pattern defects, on the surface ..." '325 at 18:27-28. This preamble plainly connotes that the claim embodies an invention used to "detect [] .. anomalies." *Id.* The body of claim 36 never mentions or refers to the preamble; it is never incorporated. '325 at 18:29-47. It is also not necessary to read the preamble of claim 36 to understand the way the elements and limitations in claim 36 cooperate to form a unified invention. *Id.* This court, therefore, holds that the preamble of claim 36 is introductory unintended to limit or define the invention contained in the claim.

Similarly, the preamble of claim 43 reads as follows: "An optical method for detection of anomalies, such as particle or pattern defects, on a surface." '325 18:66-67. Whereas, claim 36 is directed to an "optical system," claim 43 is directed to an "optical method." The same reasoning used to conclude that the preamble of claim 36 is only introductory applies with equal force to claim 43. This court, therefore, holds that the preamble of claim 43 is also not limiting.

2. "two or more sensors"

KLA maintains that "two or more sensors" as used in the '325 patent means two or more PMT type detectors. D.I. 338 at 14-18. ADE argues that the phrase should mean two or more groups of sensors. D.I. 316 at 20-25.

This court holds that "two or more sensors" as used in claims 26 and 43 of the '325 patent means two or more PMT type detectors. Referring to Figure 4, reproduced below, of the '325 patent, the written description provides that:

"[E]ach collector channel 10a-b and 11a-b includes a lens system 113 that collects scattered light. A series of mirrors 114a-c reflect the light so that it is imaged onto a photomultiplier tube (PMT) 115." The PMT 115 converts the light impinging thereon into an electrical signal having a voltage level that is proportional to the to the light intensity."

'325 at 6:39-49.

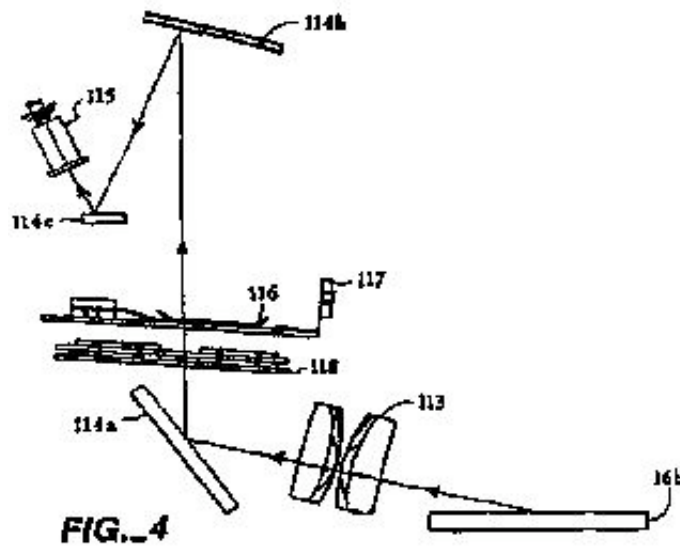

This construction is also supported by statements made by the inventors during patent prosecution. Originally, claims 36 and 43 (numbered claims 39 and 45 during prosecution) contained the phrase "a two-dimensional array of sensors." D.I. 338 at 16. The examiner rejected these claims seeking clarification of the meaning of "a two-dimensional array of sensors." *Id.* The applicants amended the claims replacing the phrase "a two-dimensional array of sensors" with the phrase "two or more sensors" and clarified that these sensors referred to Figures 1, 2, and 10 of the '325 patent. *Id.* Figures 1, 2, and 10 depict PMT type detectors (See Figure 4 and '325 7:39-45 describing collector channels 10a-b and 11a-b). '325 at 6:39-45. Clear support for KLA's claim construction is found in the intrinsic record of the '325 patent. Accordingly, this court holds that "two or more sensors" as used in the '325 patent means two or more PMT type detectors.

3. "maps," "providing a map," "identifying anomalies"

KLA argues that "maps" include stored sensor or output signals, "providing a map" has an ordinary meaning-to provide a map, and "identifying anomalies" means an identification of anomalies by type. D.I. 338 at 19-22; D.I. 416 at 31-34. On the other hand, ADE argues that "map" means a visual display, "providing a map" means first forming a map for the entire wafer and then processing the stored detector output in a distinct step, and "identifying anomalies" means identification of the presence or absence of anomalies. D.I. 316 at 14-17; D.I. at 2-13.

Claim 36 of the '325 patent differs from claim 43 of the '325 patent in that claim 36 is directed to an "optical system" but claim 43 is directed to an "optical method." Both claims use the language, "maps," "providing a map," and identifying anomalies." This language, as it appears in claim 36, is reproduced below for purposes of representation:

a processor providing a plurality of maps by providing a map from said stored sensor output signals from each of the two or more sensors during the scan and comparing at least two of the maps for identifying anomalies

'325 at 18:41-47.

It is evident from reading the above quoted language that "maps" are provided from "stored sensor output

signals" and compared to identify anomalies. This claim language is straightforward and supported by the written description. The inventors' description provides that "[t]he processor 500 compares the data stored in memory at addresses represented by the map shown in FIG. 7A with the data stored in memory represented by the map shown in FIG. 7B." '325 at 7:67-8:3 This data, as represented by the maps shown in Figures 7A and 7B, reproduced below, is compared using logical OR and AND operators to construct the composited maps represented by Figures 7C, 7D, and 7E. '325 at 8:3-23. Clearly, the visual display or "maps" referred to in the '325 patent include the underlying stored data because "[t]he processor 500 compares the data stored in memory...." *Id.* The visual display is merely a "representation" of the data. *Id.*

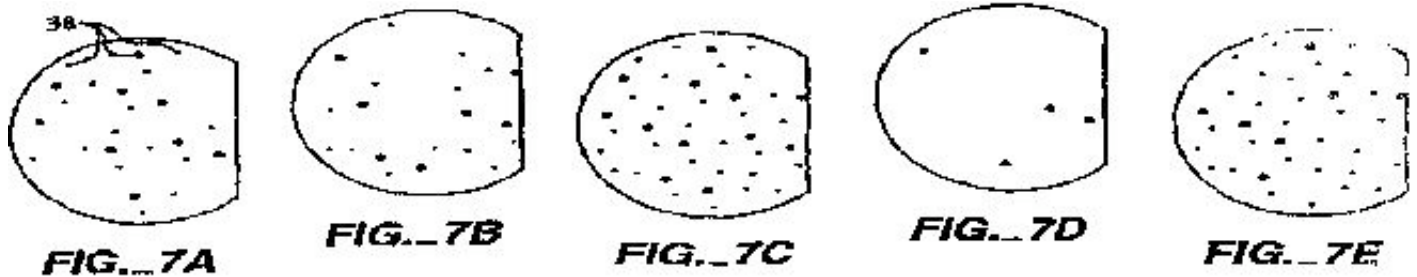

Consistent with the inventors' written description and the plain meaning in the art of the words used in the claims, this court construes the word "maps" to include the underlying stored data that is displayed visually as in Figures 7A-7E of the '325 patent. Furthermore, "providing a map" is construed to mean that different "maps" may be generated by the processor. The phrase "identifying anomalies" as used in claims 36 and 43 is construed to mean identification of the presence or absence of anomalies on the surface of silicon wafers. '325 at 14:58-15:5. Had the inventors intended a different meaning for "identifying anomalies," such as "classifying anomalies," they could have drawn such a distinction in their claims as was done in the written description where it reads that:

The processor 500 constructs maps from the signals produced by the inspection channels.... The processor compares the maps from the inspection channels either in the analog domain or digitally, by performing logical operations on the data, e.g., AND, OR and XOR, in the manner described above, to detect anomalies. The processor forms composite maps, each representing the detected anomalies by a single group of symmetrically disposed collector channels. The composite maps are then compared so that the processor may classify the anomalies as either a pattern defect or particulate contamination.

Id.

Having failed to use the term "classify" in the claims this court will not misconstrue the word "identify[]" as used in the claims to impart a meaning inapposite to that commonly understood in plain English and in the art to which the invention is directed. This court holds, therefore, that the phrase "identifying anomalies" means just that-to identify the presence or absence, as the case may be, of anomalies on the surface of a silicon wafer or similar article.

3. "an optical element collecting light scattered"

Unlike the previous disputed terms or phrases in the '325 patent, the phrase "an optical element collecting

light scattered" appears only in claim 36. ADE does not assert any specific meaning for the phrase. KLA, however, maintains that the phrase means that a plurality of optical elements collect scattered light from the surface of a silicon wafer during scanning and distribute said light to two or more PMT type detectors. D.I. 338 at 18. This court agrees, in part, with KLA's argument.

Claim 36 recites "an optical element." '325 at 18:31-37. The indefinite articles "a" or "an" can carry the meaning of "one or more" given an open claim format (a claim using the word comprising, including, or similar terminology). *North Am. Vaccine, Inc. v. Am. Cyanamid Co.*, 7 F.3d 1571 (Fed.Cir.1993). To the extent that KLA construes this phrase to mean that a "plurality" of optical elements is an affirmative element of claim 36, this court disagrees. The '325 disclosure teaches that more than one optical elements can collect scattered light from the surface during a scan. '325 at 6: 39-41. Claim 36 claims "an optical element." '325 at 18:31-37. It does not claim a "plurality" of optical elements to the exclusion of a single optical element.

In terms of defining the scope of a patented invention there may exist a contrast between an invention that reads upon a device containing "an optical element" (meaning one or more) and an invention that requires as an element a "plurality" of optical elements. For example, a claim preceded by the transitional word "comprising" and containing as an element "an optical element" may read on a device with "one" or a "plurality" of optical elements. A claim preceded by the transitional word "comprising" and containing as an element a "plurality" of optical elements would not necessarily read upon a device with only "one" optical element. Infringement in this later scenario would depend upon whether a patentable distinction exists between an invention with "an optical element" and an invention with a "plurality" of optical elements.

Without making any ruling as to whether a patentable distinction does or does not exist in the present litigation with respect to "an optical element" or a "plurality" of optical elements, this court holds that the phrase "an optical element collecting light scattered" means that one or more optical elements collects light. It does not mean that a "plurality" of optical elements collects light to the exclusion of collection of scattered light by a single optical element. Although this may be a splitting of the proverbial hair, inventors are entitled only to what is claimed, not what the claim language is later asserted to subsume for the purposes of litigation. *Bell & Howell DMP Co. v. Altek Sys.*, 132 F.3d 701 (Fed.Cir.1997); *see also* *Roton Barrier, Inc. v. Stanley Works*, 79 F.3d 1112 (Fed.Cir.1996).

V. KLA-Tencor's '710 and '551 Patents

A. Claim 1 FN16 and Claim 24 FN17 of the '710 Patent and Claim 1 FN18 and Claim 3 FN19 of the '551 Patent

1. "grazing angle" of the '710 Patent and "an angle" of the '551 Patent

The first element of claim 1 and claim 24 of the '710 patent use the phrase "grazing angle" to depict the angle at which the invention focuses a beam of light at the surface being inspected. '710 at 13:9, 14:63. In claim 1 and 3 of the '551 patent (a continuation of the '710 patent application) the phrase "an angle" is used to describe a similar function. '551 at 13:12, 13:28. The parties contest the meaning of these phrases. KLA asserts that "grazing angle" as used in the '710 patent and "an angle" as used in the '551 patent refers to any angle other than an angle normal to the surface being inspected. D.I. 340 at 11; D.I. 409 at 27. ADE argues that "grazing angle" is commonly understood to one of ordinary skill in the art to refer to an angle close to

the surface being inspected and would limit the meaning of "grazing angle" to an angle between 0 and 10 degrees of the surface. D.I. 314 at 10-12. As to the phrase "an angle" ADE argues in their Opening Brief (D.I.314) that "this phrase must be interpreted in the same manner with regard to the '551 patent as explained above regarding the 710 patent" and, then, argues in its Responsive Brief (D.I.398) that the phrase "an angle" encompasses 90 degrees or normal incidence. D.I. 314 at 15; D.I. 398 at 15.

This court construes the phrase "grazing angle" as used in the '710 patent and the phrase "an angle" as used in the '551 patent to mean any angle other than an angle normal to the surface being inspected. This meaning is consistent with that taught in the written description and depicted in the drawings of the '710 and '551 patents. Figures 2, 3, 6, 7A, and 7B of the '710 and '510 patents depict either explicitly or implicitly an angle or angles for the focused beam of light other than an angle normal to the surface being inspected. For example, Figure 6, reproduced below to the left of Figure 3, uses the mathematical expression $w/\cos(\theta)$ to describe the magnitude of the long axis of the ellipse (or the spot of light used to scan the surface being inspected) with (θ) representing the angle shown in Figure 3, reproduced below, and w representing the minimum width (or length of the sort axis of the spot). '710 at 9:53-60; '551 at 9:53-60.

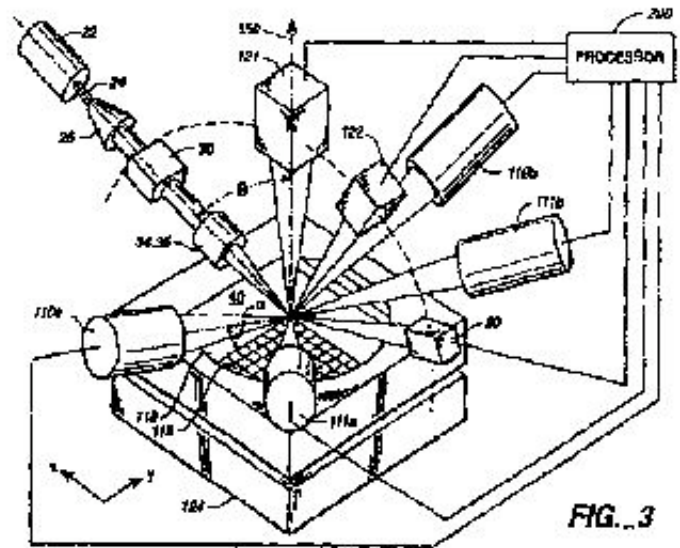
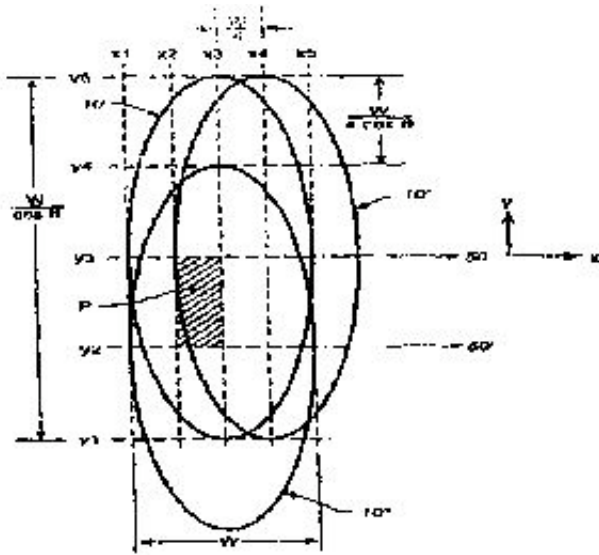

The angle (θ) depicted in Figure 3 and used in the above equation is the angle between 150, or a line normal to the surface being inspected, and the directed beam of light used to scan the surface. Thus, as angle (θ) approaches 90 degrees, or normal, the magnitude of the long axis of the ellipse gets smaller. If this angle approaches 0, or the surface, this axis gets bigger, but if angle (θ) is 90 degrees, normal to the surface, this equation becomes meaningless. A person of ordinary skill in the art would readily understand this mathematical equation and its significance in relation to the patented invention.

The written description of the '710 and '551 patents do not limit "grazing angle" or "an angle" (angle (θ) in Figure 3) to any particular angle or angular range other than a normal angle. ADE, however, argues that the "grazing angle" has a commonly understood meaning in the art referring to an angle of incidence close to the surface being inspected. Furthermore, ADE asserts the inventors understood this meaning and used the phrase accordingly. ADE may or may not be correct in their argument that the inventors had a general

understanding of the common art meaning of the phrases "grazing angle" and "an angle" at the time of filing the '710 and '551 patents. The inventors' supposed understanding is unimportant in the present case given that the inventors specifically provided a description for "grazing angle" and "an angle" in the '710 and '551 patents so that a person of ordinary skill in the art could read the patent and determine what angle was necessary to generate varying magnitudes for the "spot's" or ellipse's long axis and, thus, use that angle to change the dimensions of the ellipse as needed to effectuate a scan.

2. "plurality of arrays of scan path segments" of the '710 Patent and "plurality of scan path segments of the '551 Patent"

KLA argues that "plurality of arrays of scan path segments" means "two or more series of scan path segments." D.I. 342 at 12-19. ADE contends that the phrase means more than one distinct group of scan path segments. D.I. 314 at 19-21.

The word "plurality" has the common art meaning referring to more than one of a specified item. The meaning of "scan path segments" is provided for in Figure 4 of the '710 and '551 patents, reproduced below, and at column 6 lines 10-61:

FIG. 4 is an exploded view of a portion of the two strips 54, 56 and smaller portions of two other neighboring strips to illustrate in more detail the above-described scanning process. In the preferred embodiment as shown in FIG. 4, the optical beam 38 scans in only one direction as illustrated by the arrows of scan path segments 50, 50', 50", 50'''. Scan path 50 has an effective start location at 72 and spot 10 moves to the right therefrom until it reaches the border 55 between strips 54 and 56. Upon reaching border 55, a stage (see FIG. 3) moves the surface 40 in the X direction perpendicular to the scanning direction Y and the spot assumes the new start position 74 and moves along a scan line 50' parallel to scan line 50. The movement of the spot 10 along scan lines 50, 50', 50", 50''' and so on is achieved by means of AOD 30 as explained below.

'710 at 6:47-61; '551 at 6:47-61.

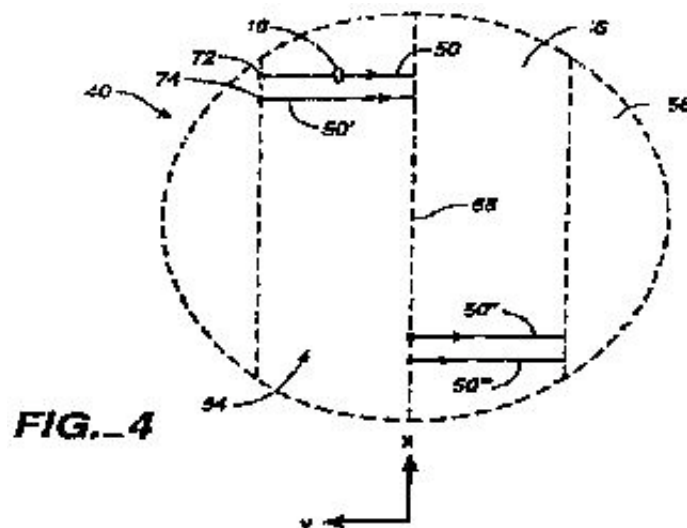

It is evident from this passage and Figure 4 that the inventors intended a "scan path segment" to refer to a scan the width of spot 10 beginning at an edge 54, location 72, and terminating at an edge 55, scan path 50, before starting again at edge 54, location 74, and terminating at an edge 55, scan path 50'. In this fashion, each rectilinear area (i.e., the area between edge 54 and edge 55 in Figure 4 above) is scanned until the entire surface is inspected so that each rectilinear area is scanned 50" prime times. Figure 2, reproduced below lends further support to this interpretation.

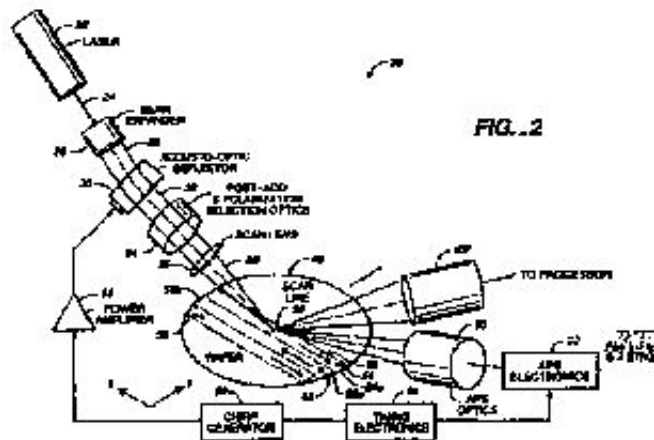

The "scan path segment" referenced above encompasses at least one embodiment of the inventors' invention. The '710 and '551 disclosures, however, teach that other embodiments of the invention exist such that scanning may be accomplished with a different scan path shape. 710 at 12:54-55; '551 at 12:54-55 ("... it is also possible for curved scan lines to be employed ..."). It is clear that the inventors intended, and this court so holds, that the entire phrase "plurality of arrays of scan path segments" means that area scans of the surface are performed using more than one distinct scan segment with a width of spot 10. The length and shape of these scan path segments must be determined, necessarily, by the embodiment of the invention being practiced.

As to the phrase "plurality of scan path segments" found in the '551 patent claims, this court construes the language consistent with the foregoing analysis and the plain meaning of the words to mean more than one distinct scan segment with a width of spot 10. However, the parties dispute whether or not this language is supported by the written disclosure. This issue is addressed, *infra*, with respect to ADE's motion for partial summary judgement of invalidity of KLA's '551 patent for lack of written description under 35 U.S.C. s. 112, para. 1.

3. "collecting light scattered along said path for detecting anomalies"

The parties' arguments in regard to the phrase "collecting light scattered along said path for detecting anomalies" centers on whether the '710 and '551 patents require that collection of light and detection of anomalies occur within the same instrument or device such that the two operations are inseparable. D.I. 340 at 19-21; D.I. 314 at 23-26. The prepositional phrase "for detecting anomalies" does modify "collecting light scattered along said path." The question, however, is whether or not said modification also imparts a single collecting/detecting device limitation on the claim element. In other words, since the claim element is not further modified by the phrase "in a single device," this court must determine whether the inventors

nonetheless taught such an understanding of their invention. To make this determination, one must look to the intrinsic record.

Figure 3, as reproduced below, depicts one embodiment of the '710 and '551 inventions.

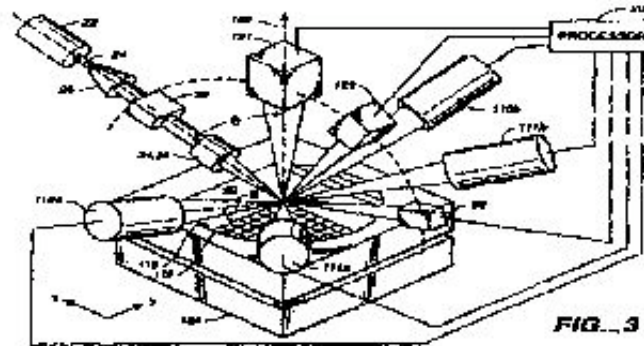

In Figure 3, 110a, 110b, 111a, and 111b represent different instrumentalities connected to a processor 200 for the collection and detection of light scattered by anomalies on the surface of the inspected article. '710 at 7:19-24; '551 at 7:19-24 ("Detectors such as detector 111b collects light scattered by anomalies as well as the surface and other structures thereon along scan line 50 [See Figure 4 Above] and provides output signals to a processor in order to detect and analyze the characteristics of the anomalies."). Later in the disclosure, the '710 and '551 written description provides that "the processor 200 in FIG.3 for processing light detected by the collection or collector channels 110a, 110b, 111a, and 111b is such that a sample is taken" '710 at 9:13-16; '551 at 9:13-16. The '710 and '551 disclosures clearly teach collection of scattered light in the collector channels represented by 110a, 110b, 111a, and 111b in Figure 3. The disclosures further specify that these collector channels produce signals sent to the processor "in order to detect and analyze the characteristics of the anomalies." '710 at 7:19-24; '551 at 7:19-24. The inventors having taught processing of the collected light by the processor 200, this court will not read the phrase "collecting light scattered along said path for detecting anomalies" as requiring collection of light and detection of anomalies to occur within the same instrument or device such that the two operations are inseparable.

B. Claim 23 FN20 and Claim 46 FN21 of the '710 Patent and Claim 25 FN22 of the '551 Patent

1. "selecting a desired polarization state ... from S state, P state, or a circular polarization state"

The dispute surrounding the phrase "selecting a desired polarization state ... from S state, P state, or a circular polarization state" has less to do with a misunderstanding as to the meaning of the individual words employed and more to do with the way in which the claim combines the three polarization states. That is, ADE argues that the phrase means that each of the three states must be present in an accused infringing device so that a "selecting" between the polarization states may occur. D.I. 314 at 26. KLA, on the other hand, argues that the phrase utilizes a Markush grouping common in patent prosecution, therefore, an infringing device can have either of the states but does not have to possess all three. D.I. 409 at 25.

This court is unconcerned for the moment about which states an infringing device must contain because it is currently focused on claim construction not a determination of patent infringement. *KCL Corp. v. Kinetic Concepts, Inc.*, 223 F.3d 1351, 1355 (Fed.Cir.2000) ("A patent infringement analysis involves two steps:

claim construction and application of the properly construed claim to the accused product."). This being so, this court construes the phrase "selecting a desired polarization state ... from S state, P state, or a circular polarization state" to mean that either S state, P state, or a circular polarization state is selected to practice the invention. The '710 and '551 disclosures are consistent with this meaning:

[T]he polarization state of the illumination beam is chosen to optimize signal-to-noise background and for defect detection, the collector or collection channels include polarization filters to pass light of predetermined polarization states to enhance detection capability and signal-to-noise ratio.

'710 at 12:44-50; '551 at 12:44-50.

VI. KLA-Tencor's '118 Patent

A. Claim 7 FN23 and Claim 13FN24

The parties dispute two claims, claim 7 and claim 13, of the '118 patent. These claims are written in means-plus-function format and have similar means-plus-function elements. Claim 7 contains three elements introduced, respectively, by the phrases: a "data storage means," a "gallery definition means," and a "gallery display means." Claim 13 also contains three elements introduced by these phrases, but the "data storage means" and "gallery display means" elements of claim 13 are limited by different language.

Means-plus-function claims are authorized by the patent statute for claims to a combination. 35 U.S.C. s. 112, para. 6. These claims are unique in that they describe the embodied invention in terms of "means or steps for performing a specified function" without reciting structure to perform the function. *Id.* The corresponding structure is provided for in the specification. *Chiuminatta Concrete Concepts, Inc. v. Cardinal Indus. Inc.*, 145 F.3d 1303, 1308 (Fed.Cir.1998). A determination of the scope of a means-plus-function claim, therefore, requires first understanding the function being performed, as found in the claim, and, then, reviewing the specification to discover the structure eluded to in the claim that performs the function. *See, e.g., In re Hayes Microcomputer Products, Inc. Patent Litigation*, 982 F.2d 1527, 1541 (Fed.Cir.1992).

1. "data storage means"

KLA argues that the "data storage means" of claim 7 and claim 13 are supported by the structure of any commercially available computer database management system. D.I. 340 at 12-13. ADE, on the other hand, argues that the "data storage means" of claim 7 and claim 13 are supported by the structure of conventional computer hardware used with general computer software to instruct the hardware to perform the function recited. D.I. 312 at 4. In addition to its argument about the meaning of "data storage means," KLA argues over the meaning of the limiting language "sets of measurement data," "related measurements," and "obtained using a predefined process" as contained in claim 7. ADE does not believe that this court needs to construe this functional language.

The "data storage means" of claim 7 differs from that of claim 13 in that the function of the "data storage means" of claim 7 is to store "sets of measurement data;" whereas, the function of the "data storage means" of claim 13 is to store "sets of data." The function, "storing sets of measurement data," in claim 7, is further limited by the words "each said set of data represent[s] a set of related measurements obtained using a predefined process." In claim 13, however, the "storing sets of data" function is limited by the words "sets of data that can be displayed graphically." Clearly, the "data storage means" of claim 7 performs a different function than that of claim 13 because the two claims are limited by different language. This court,

therefore, will construe the two "data storage means" separately. *See* Glaxo, Inc. v. Novopharm. Ltd., 110 F.3d 1562 (Fed.Cir.1997) (All claim limitations are material to defining the scope of an inventor's invention.).

Beginning with claim 13, "data storage means" is functionally limited by "storing sets of data that can be displayed graphically." The only structure disclosed in the '118 patent capable of storing "data that can be displayed graphically" is conventional computer hardware running with conventional computer software as incorporated into the '118 specification by reference. FN25 This court, therefore, construes the "data storage means" of claim 13 to be conventional computer hardware storage equipment and conventional computer software to implement the function being performed by such hardware. Turning now to claim 7, "data storage means" is functionally limited by the fact that this "data storage means" stores "sets of measurement data." The '118 specification provides that conventional computer hard drives, diskettes, and commercially available database management systems, such as Oracle(TM) or MDBS IV (TM) store measurement data for use in the '118 invention. '118 at 4:45-50, 12:67. This court, therefore, construes the "data storage means" of claim 7 to include commercially available database management systems such as Oracle(TM) or MDBS IV(TM) as well as conventional computer hardware storage equipment and conventional computer software to implement the function being performed by such hardware.

The last remaining issues with respect to the "data storage means" element of claim 7 are the meaning of the phrases "sets of measurement data," "related measurements," and "obtained using a predefined process." FN26 These phrases are blatantly straightforward. First, the inventors do not disclose the particular "sets of measurement data" being stored nor do they have to. The '118 patent is directed to an analysis and process control system for use in the semiconductor wafer inspection industry. The inventors' invention does not encompass specific measurement data. This "data" or "set of measurement data," however, would be understood by one of ordinary skill in the art to be "measurement data" relevant to distinguishing between pit and particle defects on the surface of silicon wafers or similar articles. Second, the phrases "related measurements" and "obtained using a predefined process" are construed consistent with the intent and purpose of the '118 invention to mean that the measurements are similar to measurements obtained earlier from a previously defined semiconductor wafer surface inspection operation.

2. The "gallery ... means" elements of claims 7 and 13

Since it is the opinion of this court that the "gallery ... means" elements of claim 7 and claim 13 are meaningless without an understanding of the word "gallery," this court will first construe that word, before construing the entire "gallery ... means" elements of the claims.

a. "gallery"

KLA argues that "gallery" is used plainly to mean the displaying of a specimen. D.I. 340 at 13-14. ADE asserts that "gallery" does not have a commonly understood meaning in the art but, as used in the '118 patent, refers to a graphical spreadsheet that does have a commonly understood meaning to a person of ordinary skill in the art. D.I. 312 at 2, 5 and 15. In particular, ADE contends that the '118 "gallery" has integrity or an existence independent of the images displayed therein. D.I. 312 at 2.

Although, as ADE correctly notes in its *Markman* briefs, the word "gallery" is used in the '118 with reference to a graphical spreadsheet, given the context in which the word is employed throughout the '118 disclosure, it is evident to this court that the inventors did not intend to incorporate a "spreadsheet" limitation with independent structure into the word "gallery." This court, therefore, will not read, as ADE

suggests, a graphical spreadsheet limitation into the meaning of the word "gallery." Had the inventors intended this word to incorporate a form with independent structure separate and distinct from the images being displayed, they could have done so in their claims. The word "gallery" is, therefore, construed to mean a representation of one or more items. This is not to state, however, that other limiting language in the "gallery ... means" elements of claim 7 and claim 13, as provided, *infra*, has no bearing on this discussion.

b. "gallery definition means"

The "gallery definition means," found in claim 7 and again in claim 13 is limited by the same language in both claims. It is the opinion of this court, therefore, that these two "means" are identical and supported in the '118 specification by the same structure. ADE argues that the structure disclosed corresponding to the "gallery definition means" element of both claims is "conventional general-purpose computer hardware running under the control of one or more 'programs.'" D.I. 399 at 3. KLA, in contrast, argues that the structure corresponding to "gallery definition means" includes, in addition to conventional computer hardware, computer "code that may be used to program a general purpose computer system to become a special purpose computer system." D.I. 340 at 21.

The "gallery definition means" element in both claim 7 and claim 13 is "coupled" to the "data storage means" element and written to have the function of "defining a two dimensional array of cells, and for assigning to each of at least a subset of said cells a cell definition selected from the set consisting of (A) one of said sets of measurement data, and (B) a mathematical combination of a plurality of specified ones of said sets of measurement data." '118 at 20:20-27, 21:27-34.

ADE argues, consistent with its arguments about the meaning of the word "gallery," that the limiting language "two dimensional array of cells" means that the "spreadsheet" function of the "gallery definition means" element "carries with it the requirement that the axes, or 'dimensions' of the array (i.e. rows and columns) have some relationship within them and that this relationship has integrity and meaning." D.I. 312 at 8. KLA argues that a plain and ordinary meaning applies to the phrase and that the phrase means that the "gallery definition means" determines the 'number of rows and [the] number of columns of elements' displayed by the "gallery display means." D.I. 340 at 14. This court agrees.

Although ADE's argument is well punctuated with one or two drawings from the '118 patent implicitly supporting their analysis, the "gallery definition means" of claim 7 and claim 13 does not contain the limitation that the "gallery" be fixed in form or have integrity, as ADE suggest, separate and distinct from the images displayed therein. This "means," however, does have a "two-dimensional array of cells" limitation and, as such, one of ordinary skill in the art would conclude that the images are depicted in a logical fashion with organized rows and columns but, since the disclosure and claims do not require a separate and distinct integrity for these rows and columns, ADE's integrity argument must fall.

Given this court's interpretation of "gallery" and "two-dimensional array of cells" the remaining language limiting the "gallery definition means" of claim 7 and claim 13 becomes clear. That language states that in addition to "defining a two-dimensional array of cells," the "gallery definition means" also "assign[s] to each of at least a subset of said cells a cell definition selected from the set consisting of (A) one of said sets of measurement data, and (B) a mathematical combination of a plurality of specified ones of said sets of measurement data." '118 at 20:20-27, 21:27-34. Thus, the structure of the "gallery definition means" "determines the two-dimensional array of cells" and selects either a "set[] of measurement data" or "a mathematical combination ... of said sets" to be displayed in the cells. *Id.* The only structure provided in the

'118 patent capable of performing such a function is conventional computer hardware and software. Nowhere does the '118 patent disclosure contain specific computer "source code" or software in the manner suggest by KLA. This court construes the "gallery definition means" element of claim 7 and 13, therefore, to be supported by the structure of conventional computer hardware and software with the function of determining what items will be displayed by the "gallery display means."

c. "gallery display means"

The "gallery display means" of claim 7 is "coupled" to the "gallery definition means" preceding it in the claim and written to have the function of "displaying a two dimensional array of cells, each cell containing a *data map* depicting a set of data in accordance with a corresponding one of said cell definitions." '118 at 20:15-32 (emphasis added). The "gallery display means" of claim 13 is "coupled" to the "gallery definition means" preceding it in the claim and written to have the function of "displaying a two dimensional array of cells, each cell containing a *graphic image* depicting a set of data in accordance with a corresponding one of said cell definitions." '118 at 21:23-40 (emphasis added).

Initially this court notes that if a "data map" is distinguishable from a "graphic image" as used in the '118 invention, then the "gallery display means" of claim 7 and that of claim 13 must have different functions because the functionally limiting language of claim 7 states that "each cell contain[s] a data map;" whereas, in claim 13, it states that "each cell contain[s] a graphic image." A review of the '118 specification indicates that a "data map" refers to the images displayed in Figures 23-28 of the '118 patent. '118: at 4:18-19.

A similar explicit reference does not exist for the term "graphic image." This court construes "graphic image," therefore, consistent with its plain meaning, to be broader than a "data map" as used in the '118 patent thus encompassing other computer displayable images. '118 at 12:17-21 ("The engineering module ... includes a chart display module ... for generating and displaying trend charts, control charts, data/wafer maps, histograms and 'galleries' of data maps."). Figures 23 and 28 of the '118 patent are reproduced below for reference.

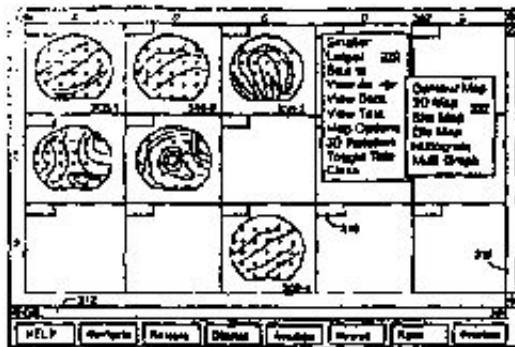

FIGURE 23

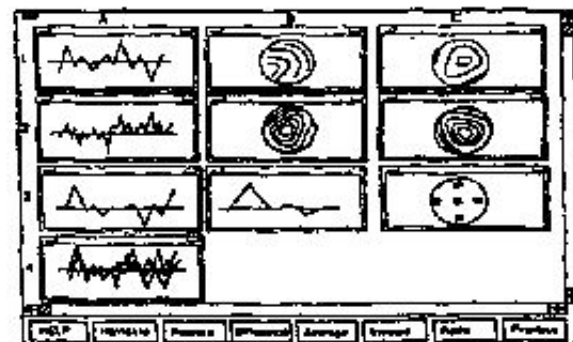

FIGURE 28

With the exception of the above terminology in the "gallery display means" of claim 7 and claim 13, the two "means" elements contain the same language. That language provides that the "gallery display means" is "coupled" to the "gallery definition means" element. Furthermore, the "gallery display means" was written to have the function of "displaying a two dimensional array of cells, each cell containing a data map [or graphic image in claim 13] depicting a set of data in accordance with a corresponding one of said cell

definitions." '118 at 20:28-32, 21:34-39.

The only structure provided for in the '118 disclosure for performing such a function is conventional computer hardware and software. This court, therefore, construes the "gallery display means" of both claims to be supported by the structure of conventional computer hardware and software with the function of displaying one or more items for comparison. The same analysis applied, *supra*, with respect to the "gallery definition means" about specified computer source code is incorporated into this discussion to hold that the '118 patent does not disclose specific "source code" supporting the "gallery display means" of claims 7 and 13.

CLAIM CONSTRUCTION SUMMARY TABLE

<i>The '525 Patent</i>	<i>Claim Construction</i>
Claim 1:	
"A surface inspection method for distinguishing between particle and pit defects on a surface of a workpiece, said method comprising:"	The preamble of claim 1 of the '525 patent does not limit the claim.
"workpiece"	A silicon wafer or similar article susceptible to particle and crystalline originate pit ("COP") defects.
"scanning the surface of the workpiece"	The entire surface of the workpiece is inspected through relative motion of the incident beam of P-polarized light and/or the workpiece being inspected. The phrase is broad enough to encompass rotation and translation of the workpiece during scanning.
"signals representative of light scattered into said zones"	Includes any signal representative of or corresponding to scattered light.
"comparing said signals"	Does not exclude the functions of normalization and subtraction.
Claim 7, Claim 8, and Claim 9:	
"signals are representative of intensities of light," "signals represent light intensities," and "intensity signal"	Includes any signal indicative of the intensity of the scattered light emitted from the surface of the silicon wafer during scanning.
Claim 19 and Claim 20:	
"sorting" and "classifying"	Sorting means to arrange particle and pit defects according to class, kind, or size. Classifying means to organize or arrange pit and particle defects according to class or category.

Claim 1, Claim 4, Claim 2, and Claim 5:

"central zone," "second oblique zone offset angularly from said first zone," "central zone includes a scattering direction substantially perpendicular to the surface," "offset at least forwardly of said first zone," "offset at least backwardly of said first zone"	"Central zone" means a light collecting zone positioned to collect light generally scattered in the normal direction and, "second oblique zone" means a second collection zone differing in polar angle from the central collection zone that does not collect the same light being collected by the "central zone" but, instead, collects either forward or backward scattered light but does not collect both simultaneously. Claims 4, 2, and 5 are not inconsistent with this construction.
---	---

The '325 Patent	
Claim 36 and	

Claim 43:	
"... detection of anomalies, such as particles or pattern defects ..."	The preambles do not limit claim 36 and 43.
"two or more sensors"	Means two or more PMT type detectors.
"maps," "providing a map," "identifying anomalies"	"Maps" includes the underlying stored data that is displayed visually. "Providing a map" means that different "maps" may be generated by the processor. "Identifying anomalies" means identifying the presence or absence, as the case may be, of anomalies on the surface of a silicon wafer or similar article.
"an optical element collecting light scattered"	Means that one or more optical elements collect light, but it does not mean a "plurality" of optical elements collect light to the exclusion of collection of light by a single optical element.
<i>The '710 and '551 Patents</i>	
Claim 1, Claim 24 of the '710 Patent and Claim 1 and Claim 3 of the '551 Patent:	
"grazing angle" and "an angle"	Means any angle other than an angle normal to the surface being inspected.
"plurality of arrays of scan path segments"	Means that area scans of the surface are performed using more than one distinct scan segment with a width of spot 10. The length and shape of these scan path segments must be determined, necessarily, by the embodiment of the invention being practiced.
"plurality of scan path segments"	Means more than one distinct scan segment with a width of spot 10.
"collecting light scattered along said path for detecting anomalies"	Does not require collection of light and detection of anomalies to occur within the same instrument or device such that the two operations are inseparable.
Claim 23 and Claim 46 of the '710 Patent and Claim 25 of the '551 Patent:	
"selecting a desired polarization state ... from S state, P state, or a circular polarization state"	Means that either S state, P state, or a circular polarization state is selected to practice the invention.
<i>The '118 Patent</i>	
Claim 7 and Claim 13:	
"data storage means"	The "data storage means" of claim 13 is supported by the structure of conventional computer hardware storage equipment and conventional computer software to implement the function being performed by such hardware. The "data storage means" of claim 7 is supported by the structure of commercially available database management systems such as Oracle(TM) or MDBS IV (TM) as well as conventional computer hardware storage equipment and general

computer software to implement the function being performed by such hardware. (See also footnote 25.)

"gallery definition means" and "gallery display means"

"Gallery" means a representation of one or more items. The "gallery definition means" is supported by the structure of conventional computer hardware and software with the function of determining what items will be displayed by the "gallery display means." The "gallery display means" is supported by the structure of conventional computer hardware and software with the function of displaying one or more items for comparison. These "gallery ... means" phrases are not supported by specific computer "source code." (See also footnote 25.)

THE SUMMARY JUDGMENT MOTIONS

I. Summary Judgement

Summary judgment applies with equal force in patent infringement cases. *Avia Group Intl., Inc. v. L.A. Gear California, Inc.*, 853 F.2d 1557, 1561 (Fed.Cir.1998). The standard is whether "the pleadings, depositions, answers to interrogatories, admissions on file, together with affidavits, if any, show that there is no genuine issue as to any material fact and that the party is entitled to judgement as a matter of law." Fed.R.Civ.P. 56(c). Summary judgment is thus granted when "no reasonable jury could find a verdict for the non-moving party." *Anderson v. Liberty Lobby, Inc.*, 477 U.S. 242, 248, 106 S.Ct. 2505, 91 L.Ed.2d 202 (1986).

The moving party may establish this burden by demonstrating that the non-moving party lacks the evidence to sustain its case. *Intel Corp. v. Broadcom Corp.*, 173 F.Supp.2d 201, 206 (D.Del.2001) (McKelvie, J); *see also Celotex Corp. v. Catrett*, 477 U.S. 317, 325, 106 S.Ct. 2548, 91 L.Ed.2d 265 (1986). If the moving party can make out this burden, the non-moving party must come forward with enough factual support to establish that there is a genuine issue for trial. *Matsushita Elec. Indus. v. Zenith Radio Corp.*, 475 U.S. 574, 587, 106 S.Ct. 1348, 89 L.Ed.2d 538 (1986); *see also Intel Corp.*, 173 F.Supp.2d at 206.

Having relegated claim construction to the *Markman* analysis provided, *supra*, the only question remaining with regard to infringement is whether the accused device embodies every limitation of the asserted claim(s). *Carrol Touch, Inc. v. Electro Mechanical Systems, Inc.*, 15 F.3d 1573, 1576 (Fed.Cir.1993); *Markman*, 52 F.3d 967, 970-971 (Fed.Cir.1995) (Patent infringement is performed in two steps. First the claims are construed and, second, the claims are applied to the infringing device.); *Athletic Alternative, Inc. v. Prince Mfg., Inc.*, 73 F.3d 1573, 1578 (Fed.Cir.1996) ("[W]here as here, the parties do not dispute any relevant facts regarding the accused produc[s] but disagree over [claim construction], the question of literal infringement collapses to one of claim construction and is thus amendable to summary judgment."). With regard to invalidity for lack of written description under 35 U.S.C. s. 112, para. 1, this court must determine whether the moving party contests new claim terminology not previously decided or new evidence not considered during the *Markman* claim construction to warrant a grant of summary judgement given that the court has performed a claim construction for all previously contested claim terminology and found it discernable. As to obviousness under the 35 U.S.C. s. 103(a), claim construction is helpful in the analysis, but obviousness is not as commingled with a *Markman* claim construction as is lack of written description.

II. The '525 Summary Judgment Motions

Six outstanding pretrial partial summary judgment motions relating to the ' 525 patent are discussed herein. In particular, this section addresses KLA's motion for partial summary judgment of noninfringement of the

'525 patent (D.I.215), KLA's motion for partial summary judgment of non-willful infringement of the '525 patent (D.I.249), KLA's motion to dismiss ADE's claims of willful infringement of the '525 patent (D.I.253), KLA's motion for partial summary judgment of invalidity of the '525 patent for lack of written description under 35 U.S.C. s. 112, para. 1 (D.I.282), KLA's motion for partial summary judgment of the '525 patent for obviousness under 35 U.S.C. s. 103(a) (D.I.336), and ADE's motion for partial summary judgment of infringement of its '525 patent by KLA (D.I.347).

A. Background

The '525 patent is directed to an invention that detects the presence of pit and particle defects on the surface of silicon wafers. The '525 invention operates by focusing a beam of P-polarized light at an oblique angle at the surface of a silicon wafer. Part of this beam is reflected by the surface of the silicon wafer while other portions of the light beam are scattered when encountering particle and pit defects. Light collectors and detectors operate in conjunction to collect the scattered light for processing and comparison. Based upon parameters known in the semiconductor industry about the scattering characteristics of pits and particles, the '525 invention is capable of distinguishing between the two types of defects. Since particle defects can be removed by recleaning the surface of the silicon wafer while pits cannot, the ability to classify the two types of defects has paramount importance in the semiconductor industry as a quality and inspection tool.

KLA's accused infringing devices, SP1^{TBI} and SP1^{DLS}, perform a function similar to the '525 patented invention. These devices also focus a light beam at the surface of silicon wafers, collect the scattered light, and use that information to distinguish between pit and particle defects. KLA attempts now and in its *Markman* briefs to differentiate the SP1^{TBI} and SP1^{DLS} devices by narrowing the focus of this inquiry, the infringement question, and the *Markman* analysis, *supra*, to whether or not the '525 contains as an element a light collection configuration different from that used in the SP1^{TBI} and SP1^{DLS} inventions. If so, KLA's argument goes, infringement does not exist directly or under the doctrine of equivalents. To appreciate this argument and the infringement question, it is necessary to fully understand how the accused devices and the '525 invention collect light scattered from the surface during inspection.

As discussed, *supra*, in the *Markman* claim construction, the meaning of "central zone" and "second oblique zone" in claim 1 of the '525 patent was heavily contested by the parties. This court, after much deliberation, held that "central zone" means a light collecting zone positioned to collect light generally scattered in the normal direction and, "second oblique zone" means a second collection zone differing in polar angle from the central collection zone that does not collect the same light being collected by the "central zone" but, instead, collects either forward or backward scattered light but does not collect both simultaneously. In contrast, ADE urged this court to adopt a construction of "second oblique zone" such that placement of additional light collectors besides the central light collector could be positioned anywhere surrounding a surface normal (in any azimuthal range) with the ability to collect both backward scattered and forward scattered light. KLA, on the other hand, advocated a construction of "second oblique zone" that would have required placement of this zone within the plane of incidence formed by the beam of P-polarized light and the surface being scanned and prevents collection of backward and forward scattered light simultaneously.

Having concluded that the inventors of the '525 patent predicated patentability on the separate collection of forward, central, and/or backward scattered light, but not on a plane of incidence configuration, this court construed "second oblique zone" such that these zones, as provided in the '525 patent, cannot collect forward and backward scattered light simultaneously in the same collection channel. Of prime interest, therefore, in this infringement analysis is whether the accused devices contain the "second oblique zone"

element of the '525 patent identically or equivalently. If not, ADE cannot prevail on its assertions of infringement.

Similar to ADE's '525 patent, KLA's SP1^{TBI} and SP1^{DLS} collect light scattered from the surface of silicon wafers using light collection and detection optics operating in conjunction. The SP1^{TBI} and SP1^{DLS} also collect scattered light, separately, in more than one collection zone. These zones, however, are arranged concentrically as depicted in the drawing provided below.

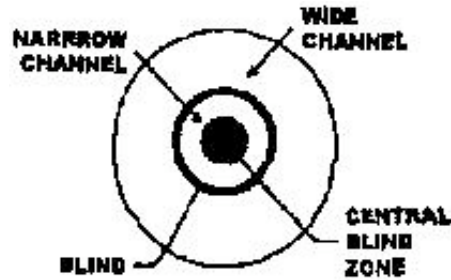

As detailed in the picture above, the SP1^{TBI} and SP1^{DLS} collect light in two concentric channels (the narrow channel and wide channel). The narrow channel in the SP1^{TBI} and SP1^{DLS} collects light scattered generally in the normal direction. The wide channel, offset obliquely from the narrow channel, collects both forward and backward scattered light simultaneously in one concentric channel for processing. This is in contrast to the '525 invention, as depicted below in the Figure 3, and this court's construction of "second oblique zone" in claim 1 of the '525 patent, *supra*, where collectors 121, 123, and 125 separately collect forward, central, and backward scattered light and direct that light to detectors 122, 124, and 126 for further processing.

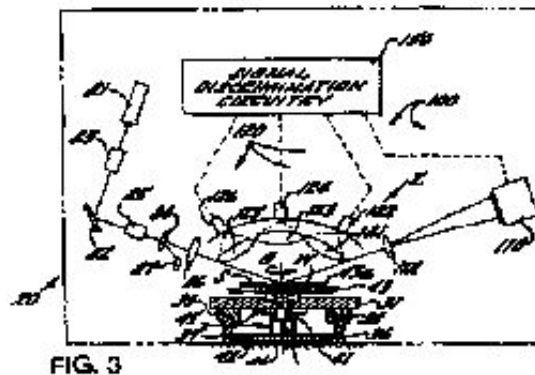

B. Infringement Analysis

ADE asserts that KLA's SP1^{TBI} and SP1^{DLS} devices infringe claims 1, 2, 5, 12, 13, 15-18, and 21 of its '525 patent. Because claims 2, 5, 12, 13, 15-18, and 21 each directly or indirectly depend upon claim 1, this infringement discussion will begin with claim 1 before turning to a discussion of the dependent claims, if

need be. Claim 1 of the '525 patent is reproduced below for reference with numerals inserted to distinguish the elements of the claim:

A surface inspection method for distinguishing between particle defects and pit defects on a surface of a workpiece, said method comprising:

[1] receiving the workpiece at an inspection station; [2] scanning the surface of the workpiece at the

[2] inspection station with a beam of P-polarized light at an angle of incidence oblique to the workpiece surface;

[3] collecting light scattered from the surface of the workpiece at the inspection station at a first central zone, and at least a second oblique zone offset angularly from said first zone;

[4] converting the collected light components from said zones into respective signals representative of light scattered into said zones;

[5] comparing said signals; and

[6] determining whether a defect is one of a pit and a particle based at least in part on said comparing.

'525 at 12:19-36.

Claim 1, as provided above, has six different elements which must be present in the accused devices either literally or equivalently for ADE to establish infringement of the '525 patent. The remainder of this discussion, therefore, will address whether each of the elements of claim 1 are present in the accused devices (SP1^{TBI} and SP1^{DLS}).

1. Do KLA's SP1^{TBI} and SP1^{DLS} receive a workpiece at an inspection station?

"[W]orkpiece" as used in claim 1 of the '525 patent was construed to encompass a silicon wafer or similar article susceptible to COP and particle defects. KLA's SP1^{TBI} and SP1^{DLS} operate such that a silicon wafer or similar article with COP and particle defects is inspected at a workstation. Neither party contests this fact. Element 1 of claim 1 of the '525 patent exists in the accused devices.

2. Do KLA's SP1^{TBI} and SP1^{DLS} scan the surface of the workpiece at the inspection station with a beam of P-polarized light at an angle of incidence oblique to the workpiece surface, convert the collected light components from said zones into respective signals representative of light scattered into said zones, compare said signals, and determine whether a defect is one of a pit and a particle based at least in part on said comparing?

Yes, given this court's construction of these elements in the '525 patent, it is evident that KLA's SP1 and SP1^{DLS} devices contain each of these elements.

3. Do KLA's SP1^{TBI} and SP1^{DLS} collect light scattered from the surface of the workpiece at the inspection station at a first central zone, and at least a second oblique zone offset angularly from said

first zone?

The answer to this third infringement question must, necessarily, be in the negative. With little doubt, the accused devices do possess a central zone for collecting light scattered generally in the normal direction similar to the '525 invention. Given this court's claim construction with regard to "second oblique zone," however, no reasonable juror could conclude that the accused devices separately collect forward and backward scattered light for processing and comparison to determine whether a defect on the surface of a silicon wafer is a pit or particle. In fact, the opposite is starkly the case. KLA's SP1^{TBI} and SP1^{DLS} products simultaneously collect forward and backward scattered light in one collection channel (the wide channel) offset obliquely from the narrow collection channel in the range of 360 degrees surrounding a surface normal protruding from the center of the surface being scanned.

Both parties agree that KLA's SP1^{TBI} and SP1^{DLS} devices are designed to collect scattered light using axisymmetric collection optics. In the abstract, the phrase "second oblique zone" in claim 1 of the '525 patent conceivably could encompass such an arrangement. The inventors of the '525 invention, however, predicated patentability of their invention on collection of scattered light separately in forward, central, and/or backward scatter directions. Having thus foreclosed the possibility of simultaneous collection of forward and backward scattered light in the same collection channel, this court is compelled to hold that a reasonable jury could not conclude that element 3 of claim 1 is present in the accused device either literally or equivalently. Moreover, if this element is lacking from the accused devices then a reasonable jury could not conclude that dependent claims 2, 5, 12, 13, 15-18, and 21 of the '525 patent are infringed literally or equivalently by the accused devices.

For the reasons provided herein, therefore, KLA's motion for partial summary judgment of noninfringement of ADE's '525 patent is granted (D.I.215). ADE's motion for partial summary judgment of infringement of the '525 patent is denied (D.I.347). As a result of the foregoing, this court does not need to address KLA's motion for partial summary judgment of non-willfulness (D.I.249), and KLA's motion to dismiss ADE's assertion of willfulness (D.I.253).

C. The '525 Motions Related to Written Description and Obviousness

1. KLA's Motion for Partial Summary Judgment Re: Invalidity of ADE's '525 Patent for Lack of Written Description (35 U.S.C. s. 112, para. 1)

KLA premises its arguments of invalidity for lack of written description under 35 U.S.C. s. 112, para. 1 on this court's adoption of a claim construction for the phrase "second oblique zone" consistent with ADE's proposed construction of this phrase. D.I. 283 at 21-29. However, this court construed "second oblique zone" to mean a second collection zone differing in polar angle from the central collection zone that does not collect the same light being collected by the "central zone" but, instead, collects either forward or backward scattered light but does not collect both simultaneously. In as much as this court has not construed "second oblique zone" consistent with ADE's proposed construction and has determined that as construed by the court the phrase is supported by the written description, KLA's motion for lack of written description (D.I.282) under 35 U.S.C. s. 112, para. 1 is denied.

2. KLA's Motion for Partial Summary Judgment Re: Invalidity of ADE's '525 Patent for Obviousness (35 U.S.C. s. 103(a))

ADE argues that it is entitled to a summary judgment of nonobviousness of the '525 patent with regard to

the combination of references KLA assert to demonstrate that the '525 patented invention is obvious under 35 U.S.C. s. 103(a). D.I. 376 at 2-30. At the very least, ADE argues, a genuine issue of material fact exists as to the obviousness of the '525 invention warranting a trial on the matter. *Id.* KLA maintains that prior art references suggest the invention disclosed in the '525 patent and thereby render it obvious and, therefore, unpatentable under 35 U.S.C. s. 103(a). D.I. 336 at.

A strong presumption of validity attaches to a patent after issuance even in the face of evidence "that was not before the PTO" during prosecution of the patent. 35 U.S.C. s. 282; *Applied Materials, Inc. v. Advanced Semiconductor Materials of America*, 98 F.3d 1563, 1569 (Fed.Cir.1996). A party arguing that an issued patent is invalid for obviousness under 35 U.S.C. s. 103(a) must establish by clear and convincing evidence all factual findings necessary to support that "the differences between the claimed invention as a whole and the prior art are such that the subject matter as a whole would have been obvious at the time the invention was made to a person of ordinary skill in the art." *Litton Systems, Inc. v. Honeywell, Inc.*, 87 F.3d 1559, 1556 (Fed.Cir.1996) (quoting 35 U.S.C. s. 103), *vacated by* 520 U.S. 111 (1997), *reinstated in relevant part by* 140 F.3d 1449 (Fed.Cir.1998). 2-36. Factors to be considered in this inquiry include: (1) the scope and content of the prior art; (2) the ordinary level of skill of people working in the field; (3) the differences between the patented invention and what already existed in the prior art; and (4) secondary considerations of nonobviousness. *Graham v. John Deere Co.*, 383 U.S. 1, 17, 86 S.Ct., 684, 694, 15 L.Ed.2d 545 (1966). Summary judgment in this matter, therefore, is proper if no genuine material dispute exists relevant to the obviousness inquiry such that a reasonable juror could conclude that the '525 invention is nonobvious under 35 U.S.C. s. 103(a). Fed.R.Civ.P. 56(c); *Ryko Mfg. Co. v. Nu-Star, Inc.*, 950 F.2d 714, 716 (Fed.Cir.1991); *Newell Cos. v. Kenney Mfg. Co.*, 864 F.2d 757, 762 (Fed.Cir.1988) *cert. denied*, 493 U.S. 814, 110 S.Ct. 62, 107 L.Ed.2d 30 (1989); *Chore-Time Equip., Inc. v. Cumberland Corp.*, 713 F.2d 774, 779 (Fed.Cir.1984) ("[C]ourts should not hesitate to avoid an unnecessary trial by proceeding under Fed.R.Civ.P. 56.").

In support of its motion for summary judgment, KLA cites numerous prior art references.FN27 In particular, KLA relies heavily on a prior art reference written by Yu, Eremin, and N. Orlov, entitled *Discrete Sources Method for the Silicon Wafers Defect Discrimination* ("*Eremin, et.al.*"). D.I. 336 at 12, 14, 15, 26-28, 31-34. This court, however, in an Order dated May 20, 2002, held that *Eremin, et. al.* was not prior art to the invention disclosed in the ' 525 patent. D.I. 467. In as much as this prior art reference pervades KLA's assertions of obviousness, this court must deny KLA's motion for partial summary judgment of invalidity of the ' 525 patent under 35 U.S.C. s. 103(a) because a material fact exist as to whether the prior art references when combined without consideration of *Eremin, et. al.* suggest either implicitly or explicitly to a person of ordinary skill in the art each element and limitation embodied by the claims of the ' 525 patent such that no reasonable juror could conclude that the invention was nonobvious under 35 U.S.C. s. 103(a).

III. The '325 Motions Related to Noninfringement

A. ADE's Motion for Partial Summary Judgment of Noninfringement of KLA's '325 Patent

Whether ADE's AWIS pit/particle classification system infringes claims 36 and 43 of KLA's '325 patent depends upon whether those claims cover both the classification and the identification of anomalies on the surface of silicon wafers. D.I. 333 at 15-22; D.I. 373 at 21-38. Stated alternatively, if the phrase "identifying anomalies" as found in claims 36 and 43 of the '325 patent means that the '325 invention as embodied by those claims identifies the presence of anomalies on the surface of silicon wafers or similar articles and also classifies those anomalies by type (pit or particle) then a court would have the further task of determining whether the remaining elements and limitations contained in those claims are found in the AWIS device

either literally or equivalently because the purpose of the channel comparison performed by ADE's AWIS device is to classify defects not identify the presence or absence of such defects. D.I. 333 at 22.

As discussed, *supra*, this court has construed the phrase "identifying anomalies" in claims 36 and 43 of the '325 patent consistent with the written description to mean that the presence or absence of anomalies on the surface of a silicon wafer or similar article are identified. This being so, this court holds that a reasonable juror could not find in favor of KLA and conclude that ADE's AWIS device infringes these claims. ADE's motion for partial summary judgment of noninfringement of claims 36 and 43 of KLA's '325 patent is hereby granted.

IV. The '710 Motions Related to Noninfringement

A. ADE's Motion for Partial Summary Judgment of Noninfringement of KLA's '710 Patent

As has been indicative of many of the pretrial case dispositive summary judgment motions in this case, ADE's infringement of KLA's '710 patent simplifies to an argument about the proper construction of a word or phrases used to claim the patented invention. With regard to the present motion, the determinative question is the meaning of the phrase "plurality of arrays of scan path segments" as used in claims 1 and 24 of KLA's '710 patent. The parties do not dispute that ADE's AWIS scans the surface using one continuous scan path. D.I. 408 at 10. Therefore, if "plurality of arrays of scan path segments" is construed to mean that the '710 patent performs area scans of the surface with more than one scan segment, then ADE's AWIS does not infringe the '710 patent either literally or under the doctrine of equivalents.

In its *Markman* analysis, *supra*, this court held that the phrase "plurality of arrays of scan path segments" means that the invention disclosed in the '710 patent performs area scans of the surface using more than one distinct scan segment with a width of spot 10. Moreover, this court held that the length and shape of these scan path segments must be determined, necessarily, by the embodiment of the invention being practiced. In light of this court's construction of the phrase "plurality of arrays of scan path segments" no reasonable juror could find that ADE's AWIS device infringes the 710 patent either literally or under a theory of equivalency. ADE's motion for partial summary judgment of noninfringement of KLA's 710 patent is, therefore, granted.

V. The '551 Motions Related to Invalidity

A. ADE's Motion for Partial Summary Judgment Re: Invalidity Of KLA's '551 Patent for Lack of Written Description (35 U.S.C. s. 112, para. 1)

In its motion for partial summary judgment of invalidity of the '551 patent under 35 U.S.C. s. 112, para. 1, ADE argues that the phrase "a plurality of scan path segments" in independent claims 1, 3 and 35-38 is not supported by the written disclosure. D.I. 330 at 2-12. In support of this contention, ADE maintains that the this claim language is broader than that taught by the inventors in the '551 specification. *Id.* Moreover, argues ADE, the prosecution history teaches that the invention operates using a "plurality of arrays of scan path segments" as opposed to "a plurality of scan path segments." *Id.* KLA counters this assertion by arguing that a person of ordinary skill in the art would have recognized at the time the patent was filed that the written disclosure and the claimed embodiment of the invention encompass scanning commensurate with the breadth of the claim language. D.I. 371 at 2-23.

ADE's motion presents an interesting situation given that the '551 patent is a continuation of the '710 application containing broader claim language than that patent and this court has construed the narrower

phrase "a plurality of arrays of scan path segments" as used in the '710 patent to mean that area scans of the surface are performed using more than one distinct scan segment with a width of spot 10. This is, however, not to say that the broader language as contained in the '551 patent is unsupported by the written description.

The question being addressed on summary judgment is whether the "pleadings, depositions, answers to interrogatories, and admission on file, together with the affidavits, if any show that there is no genuine issue as to any material fact and the moving party is entitled to judgment as a matter of law." *See* Beckon, Dicks on & Co. v. Inverness Med. Tech., Inc., 176 F.Supp.2d 258, 272-73 (D.Del.2001) (McKelvie, J.) (citing Fed.R.Civ.P. 56(c)); *accord* Glaxo Welcome Inc. v. Genentech. Inc., 107 F.Supp.2d 477, 488 (D.Del.2000) (McKelvie, J.). It is the opinion of this court that a material fact does exist as to whether a person skilled in the art of silicon wafer inspection would consider the broader language of the '551 patent supported by the written description. *See* Monsanto Co. v. Michigan Plant Science Inc., 61 F.Supp.2d 133, 188 (D.Del.1999) (quoting Regents of the Univ. of California v. Eli Lilly & Co., 119 F.3d 1559, 1566 (Fed.Cir.1997) ("To satisfy the written description requirement, the patent's specification must describe an invention in sufficient detail so that one skilled in the art can conclude that 'the inventor invented the claimed invention.' "); *see also* *Id.* (quoting *In re Gosteli*, 872 F.2d 1008, 1012 (Fed.Cir.1989) ("The applicant need not describe the subject matter claimed in exact terms. However, 'the description must clearly allow persons of ordinary skill in the art to recognize that [the inventor(s)] invented what is claimed.' "). This question is distinct from a construction of the '551 claim language in that a person of ordinary skill in the art may conclude that the language, although clear on its face, is unsupported by the written description. This court holds, therefore, that the issue of invalidity of the '551 patent under 35 U.S.C. s. 112, para. 1 is not amenable on summary judgment.

CONCLUSION

One can hardly disagree that a *Markman* patent claim construction is an exercise in linguistics requiring a court to delve into the latent ambiguities remaining in the intrinsic patent record after issuance. The inventors and the United States Patent and Trademark Office at the time of issuance achieved a mutual understanding as to the scope of the invention claimed. At some later point in time and in the mix of patent infringement litigation, this mutuality of understanding is encroached by both the accused infringer and the original inventors in an effort to mutate for one's own profit that which was freely disclosed to the public in exchange for exclusionary rights. Sitting, contrarily, between these opposing parties is the court when it performs its *Markman* analysis. No doubt, this will not be the last time that this court will find itself in this ubiquitous situation.

The court will issue an appropriate order accompanying this memorandum opinion.

FN1. Hereinafter, the patents discussed in this opinion are referred to as the '525, '710, '551, '325, and '118 patents respectively.

FN2. The '551 patent stems from a continuation of the '710 patent application.

FN3. The distinction between COP and particle defects is significant because a particle defect can be removed during recleaning, but a COP cannot. A large number of COPS on the surface of a silicon wafer,

therefore, make it unusable.

FN4. Claim 1: A surface inspection method for distinguishing between particle defects and pit defects on a surface of a workpiece, said method comprising:

[1] receiving the workpiece at an inspection station;

[2] scanning the surface of the workpiece at the inspection station with a beam of P-polarized light at an angle of incidence oblique to the workpiece surface;

[3] collecting light scattered from the surface of the workpiece at the inspection station at a first central zone, and at least a second oblique zone offset angularly from said first zone;

[4] converting the collected light components from said zones into respective signals representative of light scattered into said zones;

[5] comparing said signals; and

[6] determining whether a defect is one of a pit and a particle based at least in part on said comparing.

FN5. Quackenbos (patent number 4,794,264) was listed in the "References Cited" portion of the '525 patent as a prior art patent.

FN6. Claim 7: The surface method of claim 1, 2, 3, 4, 5, or 6, wherein the signals are representative of intensities of the light scattered into said zones.

FN7. Claim 8: The surface inspection method of claim 1 wherein said signals represent light intensities and said determining comprises deciding that a particle is present if the intensity signal from said second zone exceeds the intensity signal from said first zone by a predetermined measure.

FN8. Claim 9: The surface inspection method of claim 8 wherein said determining comprises deciding that a particle is present if the ratio of said intensity signal from said second zone to said intensity signal from said first zone exceeds a threshold value.

FN9. Claim 19: The surface inspection method of claim 1 including sorting the workpieces based at least in part on whether the determining decides that the defect is a pit or a particle.

FN10. Claim 20: The surface inspection method of claim 19 wherein said sorting includes classifying the workpiece for recleaning in response to determining that the defect is a particle.

FN11. Claim 4: The surface inspection method of claim 1, wherein said central zone includes a scattering direction substantially perpendicular to the surface.

FN12. Claim 2: The surface inspection method of claim 1 wherein said second scattering zone is offset at least forwardly of said first zone.

FN13. Claim 5: The surface inspection method of claim 1 wherein said second scattering zone is offset at least backwardly from said first zone.

FN14. Claim 36: An optical system for detection of anomalies, such as particles or pattern defects, on a surface comprising:

[1] an optical source providing a beam of radiation illuminating the surface; two or more sensors;

[2] an optical element collecting light scattered from the surface and directing the collected and scattered radiation to the two or more sensors, causing the sensors to provide output signals in response thereto, each of the two or more sensors located to sense radiation scattered from the surface scanned by the beam;

[3] a device causing relative motion between the beam and the surface so that the beam is caused to scan the surface and so that the two or more sensors provide output signals in response to radiation from different parts of the surface scanned by the beam;

[4] a storage storing said sensor output signals; and

[5] a processor providing a plurality of maps by providing a map from said stored sensor output signals from each of the two or more sensors during the scan and comparing at least two of the maps for identifying anomalies.

FN15. Claim 43: An optical method for detection of anomalies, such as particles or pattern defects, on a surface comprising:

[1] illuminating the surface of a beam of radiation;

[2] collecting light scattered from the surface and directing the collected and scattered light to two or more sensors, causing the sensors to provide output signals in response thereto, each of the two or more sensors located to sense radiation scattered from the surface in directions different from those of radiation sensed by

the other sensor(s);

[3] scanning the beam across the surface so that the two or more sensors provide output signals in response to radiation from different parts of the surface scanned by the beam;

[4] storing said sensor output signals; and

[5] providing a plurality of maps by providing a map from said stored sensor output signals from each of the two or more sensors during the scan and comparing at least two of the maps for identifying anomalies.

FN16. Claim 1: A method for detecting anomalies on a surface; comprising the steps of:

[1] directing a focused beam of light at a grazing angle towards said surface;

[2] causing relative motion between the beam and the surface so that the beam scans a scan path covering substantially the entire surface, said path including a plurality of arrays of scan path segments, wherein each of at least some of such scan path segments has a span shorter than the dimensions of the surface; and

[3] collecting light scattered along said path for detecting anomalies.

FN17. Claim 24: A system for detecting anomalies on a surface; comprising:

[1] means for directing a focused beam of light at a grazing angle towards said surface;

[2] means for causing relative motion between the beam and the surface so that the beam scans a scan path covering substantially the entire surface, said path including a plurality of arrays of scan path segments, wherein each of at least some of such scan path segments has a span shorter than the dimensions of the surface; and

[3] means for collecting light scattered along said path for detecting anomalies.

FN18. Claim 1: A method for detecting anomalies on a surface; comprising the steps of:

[1] directing a focused beam of light at an angle towards said surface;

[2] causing relative motion between the beam and the surface so that the beam scans a scan path covering substantially the entire surface, said path including a plurality of scan path segments, wherein each of at least some of such scan path segments has a span shorter than the dimensions of the surface;

[3] collecting light scattered along said path; and

[4] processing information in the collected light to detect anomalies.

FN19. Claim 3: A system for detecting anomalies on a surface; comprising:

[1] optics directing a focused beam of light at an angle towards said surface;

[2] a moving stage causing relative motion between the beam and the surface so that the beam scans a scan path covering substantially the entire surface, said path including a plurality of scan path segments, wherein each of at least some of such scan path segments has a span shorter than the dimensions of the surface;

[3] one or more detectors collecting light scattered along said path; and

[4] a processor processing information in the collected light from the one or more detectors to detect anomalies.

FN20. Claim 23: The method of claim 1, said method further comprising selecting a desired polarization state of a light beam that is directed in the directing step from S state, P state, or a circular polarization state.

FN21. Claim 46: The system of claim 24, said system further comprising selecting a desired polarization state of a light beam that is directed in the directing means from S state, P state, or a circular polarization state.

FN22. Claim 25: The system of claim 3, said optics including an acousto-optic deflector deflecting the light beam in order to scan said surface.

FN23. Claim 7: A data analysis system, comprising:

[1] data storage means for storing sets of measurement data, each said set of data representing a set of related measurements obtained using a predefined process;

[2] gallery definition means, coupled to said data storage means, for defining a two dimensional array of cells, and for assigning to each of at least a subset of said cells a cell definition selected from the set consisting of (A) one of said sets of measurement data, and (B) a mathematical combination of a plurality of specified ones of said sets of measurement data; and

[3] gallery display means, coupled to said gallery definition means, for displaying a two dimensional array of cells, each cell containing a data map depicting a set of data in accordance with a corresponding one of said cell definitions.

FN24. Claim 13: A data analysis system, comprising:

[1] data storage means for storing sets of data that can be displayed graphically;

[2] gallery definition means, coupled to said data storage means, for defining a two dimensional array of cells, and for assigning to each of at least a subset of said cells a cell definition selected from the set consisting of (A) one of said sets of data, and (B) data resulting from a specified mathematical operation performed on one or more specified ones of said sets of data; and

[3] gallery display means, coupled to said gallery definition means, for displaying a two dimensional array of cells, each cell containing a graphic image depicting a set of data in accordance with a corresponding one of said cell definitions.

FN25. Although the '118 specification does not contain specific computer "source code," the specification does incorporate by reference patented computer software programs as part of the '118 patented invention. *See e.g.* '118 at 4:55-56 ("As explained in greater detail in U.S. Pat. No. 4,679,137, the engineering module 26 is a set up control program ..."); '118 at 5:20-22 ("As described in U.S. Pat. No. 4,873,623, the operator process control program 28 includes a process selection program...."). The expression "conventional computer software" as used by this court in the '118 patent claim construction, therefore, includes those computer software programs, such as the aforementioned, disclosed and incorporated by reference in the '118 patent.

FN26. The limiting language "sets of measurement data," "related measurements," and "obtained using a predefined process" is not found in the "data storage means" element of claim 13. This limiting language was also considered by the court when deciding that the "data storage means" elements of claim 7 and claim 13 are different.

FN27. KLA cites the following references as prior art to the '525 patented invention: (1) U.S. Patent No. 5,712,701; (2) Japanese Laid-Open Publication No. 63-284455; (3) Yu, Eremin, N. Orlov, *Discrete Sources Method for the Silicon Wafers Defect Discrimination*; (4) U.S. Patent No. 5,903,342; (5) U.S. Patent No. 4,794,264; (6) U.S. Patent No. 6,271,916; (7) U.S. Patent Application Ser. No. 08/533,632; (8) Japanese Patent Application Disclosure Number H5-332946; (9) T. Fuijise et al., *Determination of COP Distribution After SC1 Cleaning by a Laser Particle Counter*; (10) Etsuo Morita et al., *Characteristics of COPS and Haze Levels on Si Wafers*; (11) Thomas L. Warner and Edward J. Bawolek, *Reviewing Angle-Resolved Methods for Improved Surface Particle Detection*; and (12) Huff et al., *Measurement of Silicon Particles by Laser Surface Scanning and Angle-Resolved Light Scattering*. D.I. 336 at 3.